

ASmet

JOINT WORKING GROUP ON
APPLIED AGRICULTURAL METEOROLOGY

AUTOMATIC CLIMATOLOGICAL RECORDING

REPORT PREPARED BY

AGMET SUBGROUP ON AUTOMATIC WEATHER RECORDING

CHAIRMAN: W. BURKE



OCTOBER 1987

22887

FOREWORD

In recent years increasing difficulty has been experienced in providing daily observations on a manual basis at climatological stations. At the same time a number of organisations concerned with environmental monitoring in this country have acquired useful experience with the automatic recording of meteorological data. Conscious of the need for reviewing the status and options presented by automatic systems, AGMET recommends in its first Report (March 1985) that a coordinated policy be drawn up. The Group is also concerned with extending weather recording to upland areas or to areas where the current recording network is poor.

The costs of automatic recording systems vary considerably and some of the less expensive systems have apparently provided satisfactory results. In the interests of uniformity of standards, compatibility of recording and quality of data, AGMET proposes that standard criteria should be established for intending purchasers of equipment. Moreover, serious consideration should be given to the archiving of the records for analysis and interpretation of the results on a wider or national scale as well as for the needs of future research. This report examines the options open to organisations wishing to provide permanent weather records using automatic means.

The report is the fruit of a dedicated subgroup of experts drawn from the principal institutions concerned with meteorological recording and very effectively steered by its chairman William Burke. Its conclusions and recommendations have been based on an authoritative analysis of the state of the art and point to a constructive and realistic but exciting new dimension for agrometeorological recording.

The report is directed to the Meteorological Service, An Foras Taluntais, ACOI, ESB, Bord na Mona and all other bodies interested in the collection of meteorological data. It is AGMET's contribution towards the development of an effective system in this country.

T. Keane
AGMET Co-ordinator

ACKNOWLEDGEMENTS

Thanks are due to all members of the study group for their contributions to the compilation of this report, especially to those who prepared position papers on the various aspects of the subject. Mr. Con O'Beara, ESB kindly prepared a special advisory note on lightning protection. Special thanks are due to P. Mc Cullen, G. Byrne, and B. Noonan, who assisted in editing the report and preparing the final version. Grateful thanks are due to Ms. Noreen Farrar who typed the report, to AFT, Kinsealy Research Centre for word processor facilities, and to the Meteorological Service for printing the report.

W. Burke,
Chairman

TABLE OF CONTENTS

	Page
Summary	1
Introduction	3
The development of an automatic network	5
Experience of automatic recording in Ireland	8
Types of Automatic Climatological Network Stations	11
Details of Automatic Recording Station Systems	13
Recommendations	23
Appendix I: Participating members	25
Appendix II: Accuracy requirements for measurements	26
Appendix III: Cost estimate	27
Appendix IV: EIRPAC Tarrifs	28
Appendix V: Meteorological equipment suppliers	29

SUMMARY

Weather is important in all activities, and meteorological data have been recorded on a wide scale in Ireland for a considerable time. Manual recording requires daily or more frequent attendance at the weather station by an observer to record data on rainfall, temperature, sunshine, wind etc.

New technology for automatic weather sensors is now available and is relatively inexpensive. Modern developments in transducers, devices for data storage, processing and transmission makes sophisticated weather recording possible and practical. This new technology which is now widely used abroad could improve greatly the quality and efficiency of climatological weather recording in Ireland.

A group was set up by AGMET to prepare a report on automatic recording of agrometeorological observations. The attached report is the result of this group's deliberations.

This report sets out the background to automatic weather recording. It provides brief descriptions of systems in operation in Denmark and the USA and outlines the limited experience to date of automatic recording in Ireland. Types of automatic climatological network stations are described and details are provided of automatic recording station systems. Included are accounts of parameters to be recorded, instruments and sensors, site selection and sensor exposure data acquisition unit, communication links, computer facilities, data base, lightning protection and power supply protection. The report makes a number of recommendations and there are five appendices. These cover participating members, and provide information on accuracy requirements, costs, EIRPAC tariffs and suppliers of equipment.

Costs

There is now a wide range of automatic weather recording equipment available. Price depends largely on degree of accuracy, quality of equipment and level of automation. The minimum recommendations by the group, for a fully automatic network station, will require an expenditure of about £9,000, although the costs would be less if suitable local processing facilities were already available. If the level of automation is reduced, or less sophisticated equipment is installed some savings can be effected, but savings should never be made at the expense of quality or accuracy of equipment. ..

The following is a summary of the main recommendations of the group:

1. That automatic climatological recording be set up on the basis of a national network, having compatible hardware and software and that it be centred on the Meteorological Service with direct access for all users to the resulting database.

2. That all individuals or organisations planning automatic weather recording, irrespective of the level of automation, be encouraged to become involved in the network and that advice be available to all such participants.

3. That parameters of air, surface and soil temperature, relative humidity, precipitation, solar radiation and wind be recorded hourly.

4. That a group, having representatives from participating organisations be set up to establish an operational system and provide liaison.

5. That initially the ESB, Bord na Mona, AFT, ACOT, and the Meteorological Service be invited to set up one automatic station each. This would provide first-hand necessary experience in sensors, data storage, transmission, processing etc and enable further expansion to take place with a minimum of problems.

6. That provision be made for the routine inspection and regular servicing of stations.

7. That provision be made for checking, servicing, calibration and repairing of equipment.

8. That while it will be necessary to start with equipment now available, Irish firms should be encouraged to develop suitable reliable equipment.

INTRODUCTION

Weather is important in all aspects of life, and weather data are widely used by many organisations in their work. The Meteorological Service which recently celebrated its 50th anniversary has been involved in all aspects of weather recording, processing, forecasting and providing information to many organisations for the past half century. Weather is used daily by An Foras Taluntais and ACOI, in connection with all aspects of farming e.g. production, disease and pest control, and fodder conservation as well as in agricultural research. Weather is vital also to the daily activities of the ESB in relation to such factors as estimating electricity demand, availability of water for hydro-electric generation, and storm damage to power lines and other structures. Bord na Mona constantly uses weather data to assess drying potential for peat harvesting and other day to day operations. Aviation, fishing and almost all marine activities rely on weather information.

Weather recording is becoming increasingly more costly to continue in the traditional way. Modern developments have made possible automatic recording, processing and transmission of data. Advantage should be taken of current technology to develop an improved system to automatically record, process and store weather data from climatological stations in a uniform manner on a countrywide basis. This is the trend in numerous countries at the present time.

Less sophisticated independent automatic stations, not linked to a network, are also quite common. Such stations are less costly but may be less accurate, less reliable and of lower quality. The level of automation in such systems is lower and greater manual intervention is required. With such stations, data processing would be limited and the full advantages of a network station would be lacking.

An AGMET subgroup was set up to investigate the possibilities of the introduction of these systems to Ireland with the following terms of reference:

To examine automatic weather recording of agroclimatological observations; review the state of the art in electronics, instrumentation, sensitivity of sensors; consider the parameters to be recorded, processing and storage methods, compatibility of systems and make appropriate recommendations.

A climatological station has at a minimum two types of sensors - rainfall and temperature - which are read at least once per day. However, where possible extra parameters are measured and for agricultural or other purposes more frequent reading of sensors is required.

There are numerous reasons why the introduction of automatic weather recording is desirable at present. The state of development of weather sensors, electronic data processing, handling and transmission makes automatic recording feasible and logical at the present time. Indeed for certain applications it is the only practical way of acquiring data. In contrast, manual recording of data involving regular attendance at sites is becoming less practical and more expensive, particularly if it involves travel or weekend working. In addition, manual recording may limit observations to those obtainable during one site visit per day whereas automatic recording enables data to be gathered as frequently as desired on a 24 hour day, 7 day week basis.

The prompt availability of precise data enables more accurate, efficient and immediate advice to be provided on crop growth, animal management, disease and pest control. It allows the use of modern sophisticated crop models with very little time lag, thus greatly improving the general efficiency of agriculture. All users of meteorological data linked to the network can have prompt access to data, thus leading to a major advance in the present service and greatly improving efficiency all round.

It opens the possibility of more readily obtaining records at remote sites where regular visits are difficult, and persons skilled or interested in weather recording are not locally available. Automatic recording and storage also creates the possibility of making data from all participating stations readily available to other authorised users. Automatic recording is also likely to result in cost saving. It eliminates the time required for daily visits to stations. This is of particular importance at the weekend where overtime payments are made for manual recording. The cost estimates of an appropriate automatic weather recording are given in Appendix III.

THE DEVELOPMENT OF AN AUTOMATIC NETWORK

The use of automatic systems is essential to fill the needs of environmental protection, agriculture, energy, transportation and other industries. Internationally, automatic climatological recording is rapidly replacing the older manual methods and is now widely used in almost all developed countries. Brief descriptions are given of systems in use in Denmark and the USA. Denmark for example operates a network of 39 stations while in the United States very sophisticated networks of automatic recording stations are now functioning. Co-operating bodies in Ireland should follow the same course for development of a national network of automatic climatological stations.

Automatic Climatological Stations in Denmark and the USA

Denmark

In Denmark thirteen climatological stations are constructed and established as described in the following and placed close to plant research stations. To complete the network another 26 stations measure identical parameters with the exception of surface wetness and soil temperatures. These stations are in general placed outside areas of agricultural interest.

The data output from the stations is automatically transmitted to a central database at the Danish Meteorological Institute. The agrometeorological service retrieves the data and performs necessary quality control, whereon the data are released for scientific use.

A specially designed communications system is used for the transmission of data from the climatological station to the Meteorological Institute.

Climatological parameters measured hourly at each station are as follows:-

- Precipitation at 1.5 m
- Air temperature at 0.2 and 2.0 m
- Relative humidity at 2.0 m
- Soil temperature at 0.1 and 0.3 m
- Global (solar) radiation at 1.5 m
- Wind velocity at 10 m
- Wind direction at 10 m
- Surface wetness (artificial surface) at 1.0 m

USA

A brief summary of the system in use in Nebraska is given below as an example of an automatic climatological recording network in the United States. Similar networks are operational in other states.

Automated Weather Data Network (AWDN)

The AWDN began in 1981 at the University of Nebraska's Centre for Agricultural Meteorology and Climatology. AWDN is a network of remote weather stations that is used to automatically collect weather data. It was demonstrated that weather data can be collected in near real-time (only hours after the fact) from remote stations. Stations selected for AWDN can automatically measure:

- Precipitation
- Air temperature
- Humidity
- Soil temperature
- Solar energy
- Wind speed
- Wind direction

How Does The Network Function?

A computer at the University of Nebraska-Lincoln calls each of the automated stations on a daily basis beginning in the early morning. These calls are initiated automatically. Data are collected over the telephone system, checked for quality and made ready for transmission to a larger computer.

The data are disseminated to users through many media. Extension agents provide a telephone recording of crop water use in some counties. Interested parties can contact the agent or other staff at the county office. The Nebraska Extension Services' Agricultural Climate Situation Committee reviews the weather situation on Mondays during the growing season and prepares advisories for public release. The use of this information by the major news networks results in related newspaper articles, and the use of prepared tape recordings help radio personnel put the information on the air. Additionally, radio stations are beginning to broadcast information (like evapotranspiration estimates) from the network on a regular basis. Occasionally this information is featured on TV broadcasts.

The Inference for Ireland

Automatic weather recording can be undertaken with various degrees of sophistication, from simple single parameter records to

complex multi-channel recording systems with fully computerised control, data acquisition and data processing. There is scope for all types of systems. However the group feels that the desirable objective at the present time is to create a national network of stations that are fully automated and communicate with a centralised data bank.

Individuals or organisations that are not in a position to fully participate in such a network can avail of suitable off the shelf cheaper units to suit their individual requirements, but they should ensure that their sensors are sufficiently accurate and that their equipment is of sufficiently high quality. They should also be encouraged to become involved with the proposed centralized network. Advice should always be available from a central source for such installations and provision should be made to include data, produced by them, in the national data base.

EXPERIENCE OF AUTOMATIC RECORDING IN IRELAND

In Ireland there are 82 climatological stations in operation (Fig. 1). As yet only limited use has been made of automatic stations. Irish experience to date with these stations has been somewhat experimental and may be summarised as hereunder. Details are based on reports received from the Meteorological Service, AFT, Bord na Mona, ESB and ACOT.

Parameters Measured

The parameters which have been measured automatically include air, ground and soil temperatures, humidity, rainfall, global radiation, net radiation, wind speed, wind run, wind direction and pan evaporation.

Sensors and sensor quality

Temperature: Temperature sensors included both P.R.Ts (platinum resistance thermometers) and thermocouples. Both types were reliable but the former gave greater accuracy.

Humidity: Humidity sensors used were capacitive sensors aspirated psychrometers and wet and dry P.R.Ts. The capacitive sensors were found to be unreliable for long term use. The aspirated psychrometers used P.R.Ts internally and were found to be reliable as were the standard wet and dry P.R.Ts. However, the use of the wet and dry sensor method required careful attention to the muslin to obtain accurate results.

Rainfall: Rainfall sensors used a tilting bucket mechanism. The quality of results were dependent on the individual models of rain gauge used. Satisfactory results were obtained from one model but this was prone to inaccuracies with high rates of rainfall or with intermittent rain. Freezing conditions caused malfunction of all automatic gauges.

Global/net radiation: Various sensors have been used i.e. pyrhemometers and tube solarimeters. The pyrhemometers were reliable and accurate while tube solarimeters were found to have inaccuracies at times. Regular cleaning of the domes was essential.

Wind speed/Wind run: Again various sensors (all cup type) were used and found to be quite reliable. Transducers included DC generators, chopper disc units and reed switch mechanisms. Reed switch mechanisms were used for run of wind applications. Wind direction: Sensors for wind direction were also reliable but some types were prone to higher maintenance requirements such as the

potentiometric type. Optical units were quite reliable while reed switch units were only suitable for low accuracy instruments.

Logging equipment

Various types of loggers were employed in the different automatic weather stations installed. One type used a data cartridge mechanism for recording but the process for extracting data from the cartridges was quite cumbersome. Solid state data loggers have been built by the AFT for certain applications due to problems with cartridge based loggers. Such modern types used solid state memory or data transmission techniques which proved to be more satisfactory. Generally a wide range of loggers have been used each with its own range of facilities. However, the need for standardisation in a network is imperative. Microcomputers and suitable interface circuitry have been used successfully and found to be highly desirable for their flexibility.

Remote acquisition

This facility functioned well when employed, however, problems were encountered with the connection between the automatic weather station and the remote acquisition unit. The problems were primarily related to cable breakage either over or underground.

Power supply

Some applications showed this section to be a source of station failure. Generally the stations functioned well where a mains supply was present. Stations without mains supply required regular attention to the battery supply and in some cases battery failure resulted in partial or total data loss. AFT has successfully used solar panels with batteries in some situations.

Lightning protection

This facility is essential for any automatic weather station. Lightning has caused partial system destruction in some cases.

Siting of equipment

Correct siting of sensors is essential for any application. This has been verified by poor exposure resulting in false data recorded.

TYPES OF AUTOMATIC CLIMATOLOGICAL NETWORK STATIONS

Basically there are two ways in which climatological data may be collected and recorded automatically.

- A "field" station for which data would be recorded and stored for collection at four weekly intervals or longer.
- An "on line" station which would allow transfer of data to a local collection point on a near real time basis.

A Schematic Diagram of an "on line" Automatic Climatological Station is shown below (Fig. 2)

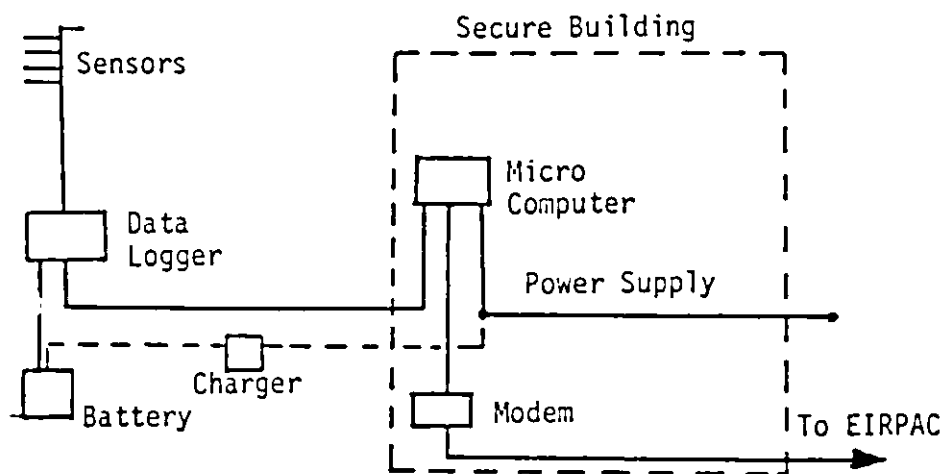

Fig. 2 Schematic Diagram of Automatic Climatological Station

It should of course be borne in mind that some attendance, perhaps weekly, would still be required at the site to ensure that the equipment receives the basic attention necessary for long term reliability.

In a typical automatic station all sensors are located on or near a mast and are individually wired to a data logger located at the base of the mast or at a secure point nearby. The data logger should contain suitable interface circuitry for all the appropriate sensors. The field station should have capacity to store data for 40 days or more. Data should be collected using a portable microcomputer for later transfer to a data base. The on line station should have a data store with a capacity for 8 to 10 days of hourly data. The data logger is linked to a local micro or mini computer which collects data at set times e.g. once daily or every hour.

At the local data collection point the micro or mini-computer would be used for medium term storage of local data. It would also

be used to send data to the data base and process local data or that retrieved from the data base as requested by local users. If local data is required in real time e.g. on an hourly basis a dedicated micro must be used while, if this is not so critical, near real time acquisition of data could be performed by an existing local mini-computer which, would also be available for other tasks.

For compatibility between stations a specific type of micro computer should be used (e.g. IBM P.C. or IBM compatible P.C.)

Data from each micro or mini computer should be sent to a central data base on a regular basis e.g. daily or weekly. An Bord Telecom's EIRPAC system could be used for this purpose. The local micro or mini computer could be used to access data from the data base for further processing. While the computer is being used for this purpose the logger can continue to collect data which would later be transferred to the micro. The central data base should be accessible to all users.

Power to the logger would normally be supplied by a battery near the mast or from the logger's own internal battery. This would be kept trickle charged by either a direct current connection via the data cable or from a solar panel. Alternatively a mains connection should be supplied, via a power cable outside any screened data link connection.

DETAILS OF AUTOMATIC RECORDING STATION SYSTEMS

Parameters to be recorded

Very careful consideration should be given to the range of parameters to be recorded, bearing in mind that often more data are recorded than are used.

Different users have their own particular requirements as to what parameters are measured. However it is clear that some combinations of certain core items are of value to most users. It is likely that the following parameters meet most requirements.

- Rainfall: Tilting bucket rain gauge.
- Temperature: Air temperature in screen.
 Surface temperature
 Soil temperature at 10 cm and 30 cm.
- Humidity: Humidity should be sensed using wet
 and dry sensors.
- Sunshine/Solar radiation: Where a sunshine/radiation option is
 required the use of a solarimeter
 (pyranometer) is preferred to a
 duration of bright sunshine recorder
- Wind speed and direction: Sensors at 10 m or wind speed only at
 2 m height.

The above constitute a suitable basis for most climatological stations. Provision should be made in the logger to enable about two extra items to be recorded. For example, Bord na Mona requires pan-evaporation data.

Instruments and sensors

It is generally agreed that the quality and sensitivity of commercially available sensors is adequate. Most are reliable and durable but automatic systems in general require checking against manual reference systems to ensure adherence to standards. The accuracy of sensors should be considered in conjunction with the overall circuitry of the logging system. Much can be done to compensate for systematic errors, thus improving on the accuracy of the records. Details of accuracy requirements for manual meteorological observations are given in Appendix II, estimates of costs of automatic stations in Appendix III, and a list of suppliers in Appendix V.

While computer operated quality control and checking of equipment is envisaged it will also be necessary to adapt methods for routine inspection and general maintenance of installations. Provision should also be made for standardisation and calibration of sensors. To ensure minimum down time for stations, caused by equipment failure, a set of key spare parts should be available at a central base. It is recommended that provision be made for the routine inspection, calibration, maintenance and the provision of spare parts as in the case of existing traditional type stations.

Rainfall Measurement:- Rainfall distribution over Ireland is very variable and a dense network of instruments is needed. The ratio of rainfall to air temperature measurement sites is about 10 to 1. A suitable instrument for automatic recording is the tilting bucket type of rain gauge. Precipitation is directed in to a bucket which tips when a certain quantity of precipitation has fallen. This closes an electrical contact to complete a circuit to increment an electronic counter in the logger. The logger could store hourly and daily rainfall, and could also be used to compute intensity of rainfall. It is difficult to measure intense rainfall accurately, mainly because of early tipping due to the momentum of the incoming rain or bounce due to the same effect. Errors in timing can arise in low intensity rainfall due to delayed tipping. However until such time as a suitable alternative is found the tilting bucket type of gauge is the preferred instrument. Rainfall should be measured at the standard level near the surface.

Temperature Measurement:- The sensors used should be platinum resistance sensors encased in protective shields. They are generally reliable, and if they fail, they do so completely making failure detection easy. The following sensors are required:

- Air temperature in screen
- Surface temperature
- Soil temperature at .1m and .3m
- Wet sensor for measuring humidity

Relative Humidity:- Humidity is computed using temperature values from the air sensor and wet sensor in the temperature screen. The wet sensor has the sensor tip covered with a muslin the end of which is dipped in a reservoir of distilled water. The muslin on the temperature sensor is kept wet by capillary action, and heat loss due to evaporation from the muslin lowers the temperature of the sensor. The difference in reading of the two thermometers is the "depression of the wet bulb". Formulae are available which can be used, given the dry bulb temperature and the depression, to

calculate the relative humidity. This would be calculated by software in the logger or local microcomputer.

Solar Radiation Measurement:- The Campbell Stokes recorder has been used for about 100 years to measure bright sunshine. Unfortunately the instrument does not lend itself to automatic recording. In the circumstances it is felt that solar radiation is a better parameter to measure. While the more useful components of solar radiation recorded are global (total), diffuse, direct and net radiation, the single component having widest applicability is global radiation. A pyranometer, which is based on a Moll thermopile incorporating a blackened receiver is used for measuring global radiation. Two optically ground and polished glass domes seal and protect the receiver. A renewable silica gel drier capsule is fitted to prevent moisture condensation within the unit. The electrical signal from the thermopile is fed to the data logger. The unit may be placed at a suitable level on a crossarm of the mast. In general, radiometers need regular inspection to ensure that they are clean.

Wind Measurement:- Wind instruments have two components: the wind speed sensor and the wind direction sensor. The wind speed has a 3 cup rotor attached which is used to drive a DC generator or an optical disc which interrupts light to a photo transistor. The electrical output is proportional to wind speed. The wind direction unit has a wind vane attached to the shaft of either a 360° potentiometer or an optical disc with optical sensors. The electrical signal(s) from the sensors represent the direction of the wind.

Site Selection and Sensor Exposure

Exposure is very important. Site selection and exposure of sensors should conform to standard basic requirements for climatological stations as set out in Observers Handbook HMSO. Wind exposure is important, e.g. wind at 2 metres can be more relevant to agriculture than wind at the standard climatological 10 metre height. However problems may occur at lower levels due to local shelter effects.

Although wind and radiation measurements are important climatological elements, individual users may have their own priorities and may not wish to record these elements. There may also be the need to measure other data such as pollution, acidity of rain and radioactivity.

Data Acquisition Unit

Central to an automatic agroclimatological station is the data acquisition unit. This unit, called a data logger, interfaces and controls the various sensors used in the station and performs some primary processing of signals or data. It also stores and transmits the data in an intelligent format, not as voltage or current values etc. but as encoded data possibly using a standard meteorological format.

The two different situations (field and on-line stations) under which climatological data need to be collected as described in the general arrangements each require a data logger which would be almost identical in each case. The essential features required of this logger are detailed as follows:

- to interface directly with all required transducers
- be expandable to accommodate extra sensors if necessary
- contain a real time clock
- be intelligent (i.e. under microprocessor control)
- have capacity to carry out some processing of data e.g. maxima, minima evaluation etc
- have a sampling speed fast enough to capture all the data in the required time interval
- have a display to indicate correct functioning of the logger
- be possible to ensure correct operation of logger remotely
- have an RS 232 or RS 422 data interface allowing connection of modems etc. where necessary
- have suitable lightning protection devices accommodated in or near the logger
- be solid state
- have low power requirement
- have sufficient battery capacity to power the logger and sensors for approximately ten days (2 months in the field station)
- capable of operating in extremely harsh environments
- have a small physical size to allow fixing to a mast
- be supplied with standard circuit diagrams having full service and operating manuals
- have a manufacturers written guarantee of replacement parts for a minimum of 5 years

Local Communication Link

The type of local link required depends mainly on the distance between the logger and the computer. RS 232 type of connections would be suitable for distances up to 100 metres (or longer by using a slow baud rate). These require 3 wires.

Distances between logger and microcomputer up to 1 kilometer can be accommodated using RS 422 type of interfaces which comprises a 4 wire line driver or short haul modem. For distance up to 5 km a 2 wire current loop would be used. Longer distances still would require the use of standard modems. Alternatively, for distances of 500 m to 10 km a pair of radio modems could be used. Installation costs for long distance cable may be substantial.

The normal data link between the logger and microcomputer would be provided by a 4 or 6 core cable. The additional cores would be used for supplying power to the logger and also to allow some spare connections.

Local Computer Facility

The local computer facility consists of a micro or mini-computer for data collection and processing, a communications link to the data base and the software necessary for handling all data transfers and local user data processing.

Local computer:- Ideally a microcomputer, dedicated to data collection and processing, should be used. However, if a micro or mini-computer is in use locally for other purposes (perhaps for word processing etc) it could be used. In the latter case real time data collection may not always be possible depending on the other tasks being performed.

Where a micro computer is used it could perform all the data transfer and processing necessary, while the software would be identical at all network stations and time consuming modifications could be avoided.

The preferable requirements for the local computer are as follows:-

- It should have a minimum of two serial communications ports; RS232 type.
- Floppy or hard discs for storage of programs and data.
- Automatic re-boot and running of programs after power interruption.
- It should contain a real time clock calender in hardware
- User programs should run simultaneously with the data transfer programs. Alternatively some type of watch-dog hardware or software is necessary to ensure that the data transfer program will run automatically after manual interruption.

While the system should be independent of the type of computer used, the choice should be standardised for the network of stations. The computer should be located in an office or other secure building as near the data logger as possible.

Software:- Ideally the software running on the computer should comprise a program or programs which perform the following functions.

- Interrogate the data logger on a timed basis or on command locally and store the data in a file on disk
- Initiate a call via EIRPAC at a fixed time each day and transfer the proceeding 24 hours data to the data base
- allow a local user to interrupt the collection of data and process data stored on disc using local programs or collect data from the data base
- allow local display of weather data
- allow interrogation of the logger on command using remote microcomputer
- allow data to be transferred in part or whole from the logger and or microcomputer remotely
- allow local and remote testing of the station using diagnostic programs or sub-routines.

Data format:- Each station should have an identifier and the data should consist of a series of lines or records containing a time and a set of observations of the meteorological parameters. Each record should have some form of sumcheck and the final one should be an end of file marker.

The records should be stored as a simple file with no special structure so that it could be printed, transmitted to another computer or processed by a program in the host machine with a minimum of difficulty. It could for example, be picked up by a spread sheet or database package directly.

Communications and Database considerations

This note discusses the transfer of data recorded at an automatic recording station to a central database, and how this database may be accessed.

User requirements and financial considerations will dictate the approach taken to data collection and the development of a database. It is obvious that user needs will differ considering the variety of interests involved.

Communications:- The transfer of data from automatic recording stations to a central database can be achieved in a number of ways. The method chosen must be reliable, efficient and inexpensive.

A communications path to a central computer can be established by using:-

- a leased line
- a dial-up link over PSTN (Public Switched Telephone Network)
- direct connection via EIRPAC network
- indirect (dial-up) connection via EIRPAC

All four methods require a modem to be installed at the recording site. The first two methods can be discounted on the grounds of cost. A leased line of 200km would cost £8000/annum (approx). A dial-up connection over the telephone network would be expensive. The EIRPAC network provides a cheaper alternative. Information on EIRPAC costs is provided in Appendix IV.

The EIRPAC network is analogous to the telephone network. User terminals or computers are connected to the network and are allocated an identifier similar to a phone number. EIRPAC is designed specifically for data traffic. It is particularly economic for low volume, short duration data exchanges. To begin a data transfer a call is made to the required destination computer/terminal.

The data generated by an automatic recording station is low volume and the EIRPAC network is an ideal vehicle for its transport to the central database. Data could also be retrieved from the central database via EIRPAC. A schematic of EIRPAC is shown in Figure 3.

To connect to EIRPAC a modem and a data circuit is required. The data circuit may be a direct leased line to the nearest EIRPAC exchange or a telephone (dial-up) line can be used. Charges on EIRPAC are distance independent. Fixed charges apply for dial-up and direct circuits to the network. Similarly the phonecall to establish a dial-up circuit is charged at the local call rate irrespective of location.

The type of connection to EIRPAC depends on the application and the frequency of use. Annual rental for a direct line costs £1100, whereas a dial-up circuit costs only £30. Since it is likely that data transfers from recording stations to a central database will take place once-a-day, the dial-up connection to EIRPAC is the

most economic.

Charges for call duration and data volumes are also levied. Appendix IV details EIRPAC tariffs and gives examples. A typical data transfer of 130 characters and less than one minute duration would cost 2.09p on a direct link and 13.26p on a dial-up link. The 11.17p difference is the local call charge for dialling EIRPAC.

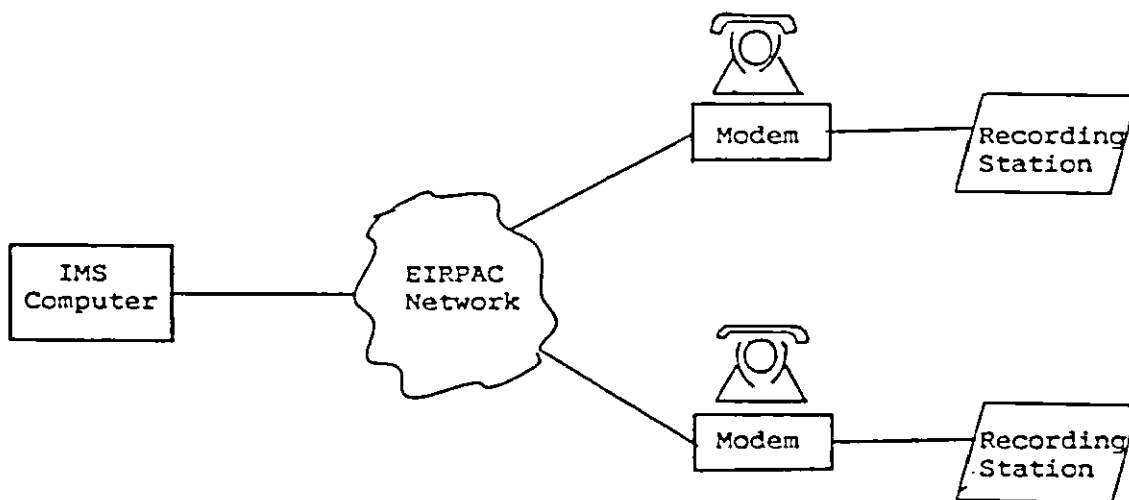

Fig. 3 - Communications over EIRPAC

Data Transfer to Central Database:- As already discussed, data transfers to the IMS computer in Dublin will probably take place on a once-a-day basis. The data transfer will be initiated at the recording station. A call to the IMS computer will be effected over EIRPAC and then software at the recording station and at the IMS computer will manage the transfer of data.

A number of software packages are available commercially. However this area requires further investigation.

The Central Database:- It is proposed that the central database be held on the IMS computer. Access to the database would be via EIRPAC with the user initiating a call to the IMS computer.

Database software may have to be purchased for this purpose. This would provide for the establishment and maintenance of the database and would also facilitate user access. Standard access methods would be introduced. A menu controlled system could be developed for retrieval of observed data and possibly standard sets of processed data (means, extremes).

The amount of data held on-line (i.e. on disk) would obviously be limited. However, online storage of a number of months of data

should not present a problem. Large volumes of data could be forwarded on request. Annual data volume for ten stations is calculated below.

No. of stations	10
Parameters	10
Characters/value	5
Observations per day	24
Days	365

4.38Mbytes

Data entering the system would be quality controlled before being made available in the database.

Lightning Protection

The level of protection required for a system will vary from station to station and depend on:-

- the probability of it being struck by lightning (this is related to the isokeraunic level which is low in Ireland)
- exposure of the system (in a field, on a building, on the side or top of a mountain).
- the value of the equipment and the data from it.

A separate structure to the sensor mast for supporting a lightning conductor could be considered but it would not guarantee immunity and might affect the parameters being read. It is better that the station is self-protecting. The essential elements are as follows:-

Air Terminal:- An anemometer, whether metal or plastic, will take lightning strokes without damage (an exception being carbon fibre reinforced plastic). However, a metal rod should project a metre above the mast and sensors for system protection. The rod should be made from solid copper, aluminium or galvanised steel of not less than 8, 10 and 12 mm diameters respectively.

Down Conductor:- The lightning should be led by the mast (or a separate conductor), around the cabinet housing the data logger. the mast (or a separate conductor). These electrical connections need be dimensioned for mechanical strength only and return bends should be avoided.

Internal Equipment and cabling:- Zener diodes can be connected to each signal core at the terminals in the equipment cabinet at the

base of the mast so that they will conduct at a low voltage onto a common earth bar. These and similar devices will deteriorate with time due to surges and weather conditions and there must be provision for periodic testing.

Signal cables should be screened (or shielded) to prevent interference and the screens should be earthed at one end only, usually at a terminal strip in the base on the cabinet. Metallic items should be earthed similarly, using a separate earthing conductor; they should also be connected to one another to maintain a common potential and prevent flashover.

Where cables are buried they should be armoured if possible and the screen and spare cores earthed at both ends using heavy copper earth wire (50 sq mm) in parallel to direct current from the screen. Maximise distance from power cables (at least 0.5 metres).

Electrodes:- The frame and earth bar should be connected to a buried electrode, as should the screens at the far end of the cable. The earth resistance should not be greater than 10 ohms; to achieve this an earth wire of copper with a cross sectional area of not less than 25 sq mm should be bonded to a galvanised iron rod of "X" or "L" cross-section preferably buried to a depth of 4 to 5 metres depending on the dryness of the earth. Alternatively this can be achieved by 20 metres of wire in good soil (wet and heavy) or if the soil is poor, sandy or dry, extra wires up to 3 x 20 metres, can be buried radiating from the cabinet.

If the equipment cabinet is on a building there may be an existing lightning protection system to which it can be connected.

Power supplies protection

Power supplies are occasionally (e.g. during thunderstorms) subject to fluctuations which may be detrimental to components in computers and other electronic systems. Surge protection devices should be used on the mains input, and rechargable batteries should be used on the DC end of the power supply if possible. This should be considered a basic precaution in all cases.

RECOMMENDATIONS

1. A National Network

Automatic recording should, from the beginning, be based on the concept of developing a national network, in which equipment and procedures are standardised and all data are transmitted to, processed and stored in a data bank at one centre. The logical centre is the headquarters of the Meteorological Service at Glasnevin. Data should be held in the computer for immediate access by stations with local computing facilities. Older data should be preserved on tape.

2. Automatic station not linked to a network

It is likely that some organisations will wish to use automatic recording but may be unable to participate initially in a national network. Technical advice should be made available to such organisations.

In particular, the availability of the guidelines covering the measurement, processing and storage of data contained in this report should provide a useful framework for those contemplating their own installation. Reference to these guidelines will ensure compatibility of the system with those of other organisations already in the field.

3. Parameters to be recorded

Individual participating stations and organisations will identify their own recording requirements but it is recommended that core data from all stations should contain as many of the following as feasible.

Precipitation: Tilting bucket rain gauge.

Temperature: - Air
- Wet sensor
- Grass min
- Soil temperature at .1m
- Soil temperature at .3m

Relative humidity: Calculated automatically from air and wet sensor values

Radiation: Global radiation

Wind: Wind speed at 2 m or Wind speed and direction at 10 m (preferable) depending on purpose of records

4. Network development

That a development group, consisting of representatives from participating organisations, be set up to establish an operational system, co-ordinate installations and provide liaison between participants.

5. Pilot stations

While it is envisaged that many organisations will eventually participate in the national network its relevance to AFT, ACOT, ESB, Bord na Mona and the Meteorological Service is immediately apparent. Accordingly those bodies should be invited to install at least one station each as soon as possible, on a co-ordinated basis.

This would enable the nucleus of a network to be set up. It would provide desirable experience for the people responsible for operating an integrated automatic system and it would ensure that the benefits of this experience would be available to all participants. In the initial stage of developing a network, maximum use should be made of existing equipment.

6. Inspection and Service of stations

All sites should be visited and serviced at least once per week. In addition to a general inspection, routine attention to water and muslin for wet temperatures sensor is required, as well as regular cleaning of the glass cover of the solarimeter.

7. Maintenance

Maintenance of the individual stations is essential and may present some difficulty but much can be done to minimise the problem. Uniformity and compatibility of equipment in a national network will make maintenance much easier. It is recommended that key spare parts be available at a central base and that adequate provision be made for checking, servicing, calibration and repairing equipment. Quality control of data at the major centre and self testing at out-stations should go a long way towards the early identification of any problems.

8. Development of equipment

Initially it will be necessary to buy all equipment from established suppliers, but the development of suitable reliable equipment by Irish manufacturers should be encouraged. Educational and research organisations should be encouraged to contribute to the development.

APPENDIX I

PARTICIPATING MEMBERS

W. Burke, AFT, Kinsealy, Dublin 17, Chairman
Mr. George Byrne, Bord na Mona, R & D Dept., Newbridge, Co. Kildare
Mr. Kieran Commins, Meteorological Service, Valentia Observatory,
Co. Kerry
Dr. Brian Coulter, AFT, Johnstown Castle, Wexford
Mr. John Dolan, Bord na Mona, R & D Dept., Newbridge, Co. Kildare
Mr. Richard Gallagher, Bord na Mona, R & D Dept., Newbridge,
Co. Kildare
Prof. Jack Grainger, Zoology Dept., TCD, Dublin 2
Mr. Jim Grant, AFT, Kinsealy, Dublin 17
Mr. Ray Kavanagh, Meteorological Service, Glasnevin, Dublin 9
Mr. Des Keppel, AFT, Oakpark, Carlow
Mr. Pat McCullen, ESB Civil Works Dept., 18-21 St. Stephens Green,
Dublin 2
Mr. Gerry McDonald, Meteorological Service, Casement Aerodrome,
Co. Dublin
Ms. Margaret McNulty, Bord na Mona, R & D Dept., Newbridge,
Co. Kildare
Mr. Brendan Noonan, Meteorological Service, Glasnevin, Dublin 9
Mr. Gerry O'Reilly, Meteorological Service, Glasnevin, Dublin 9
Mr. Julian Roberts, Regional Technical College, Carlow

APPENDIX II

SUMMARY OF ACCURACY REQUIREMENTS FOR SURFACE
MEASUREMENTS FOR MANUAL INSTRUMENTS *

Element	Climatology	Agricultural meteorology
I. Precipitation		
1. Total amount between two observations	0.1 mm up to 10 mm $\pm 2\%$ for larger amounts	0.2 mm up to 10 mm $\pm 2\%$ for greater amounts
2. Intensity	$+ 0.5$ mm/h up to 25 mm/h $\pm 2\%$ for greater amounts Mean value over 1 minute is required	$+ 5\%$ over periods of 15 minutes
II. Temperature and Humidity **		
1. Dry bulb temperature	$\pm 0.1^\circ\text{C}$	$\pm 0.1^\circ\text{C}$
2. Wet bulb temperature	$\pm 0.1^\circ\text{C}$	***
3. Relative humidity	$\pm 3\%$	$\pm 1\%$
III Wind		
1. Direction	$\pm 10^\circ$	$\pm 10^\circ$ Mean value over 2 minute periods are required
2. Speed	± 0.5 m/s	$\pm 10\%$ above 1 m/s

(*) Adapted from Guide to Meteorological Instruments and Methods of Observation. W.M.O. No. 8, fifth edition, 1983

(**) The minimum lag of the sensor for all temperature and humidity measurements is to be such that not more than 90% of change which is equal to the required accuracy is indicated in 3 minutes (1 minute for agricultural meteorology)

(***) Required to be of sufficient accuracy to give stated relative humidity accuracy.

APPENDIX III

TYPICAL COST ESTIMATE OF AUTOMATIC STATION

	£	STG.	
Sensors: Temperature Air	92		*
Wet sensor	92		*
Surface	92		*
Soil 10 cm	92		*
Soil 30 cm	92		*
Radiation screen for wet and dry thermometer (1)	-		
Rainfall-tilting bucket type	442		*
Solarimeter with screen and mountings	580		*
Wind run sensor	530		
Wind direction sensor	553		
Mast 3 m	332		*
10 m	650		
Data logger			
16 channel unit	1680		*
Interface for additional channels if required	580		
Enclosure for logger (stainless steel)	420		*
Cabling for sensors on 3 metre mast	648		*
Lightning protection device	149		*
Battery	100		*
Solar panel and charging circuit	650		
Documentation and calibration	350		*
Data acquisition			
RS 232 interface opto isolated (2)	110		*
Logger editor and utilites software for IBM PC - if required	130		*
IBM compatible micro computer - if required	1100		*
Total	£6501		
(IR £1 = STG£.9)		IR£7223	
		Vat 25% £1805	
Total (items marked * included)			£9028

(1) Assumed that existing screen is adequate

(2) Where the distance between the logger and the PC is greater than about 100m a pair of modems is required instead at an approximate cost of £375 stg.

The above estimates apply to a network station. Non network stations are correspondingly cheaper. Costs do not include installation, maintenance, or EIRPAC connection.

APPENDIX IV
EIRPAC TARIFFS

EIRPAC tariffs comprise access, usage and facilities charges. Each category has two components. Facilities charges are not included as they are not relevant.

	<u>Access</u>		<u>Usage</u>	
	connection (once-off)	Rental Annual	Duration (per min)	Volume (per segment) 1 segment = 64 characters
Dial-up (X28)	£40	£30	2.0p	0.03p
Direct (X28)	£230	£1100	2.0p	0.03p

The following examples calculate the cost of a typical transfer of data from a recording station. The data volume is 130 characters. The call duration would be less than one minute for this data volume.

Example 1 costs the transfer for a station with a dial-up circuit and Example 2 costs the transfer for a station connected directly to EIRPAC.

Example 1 - Dial-up circuit

A local call charge (11.17p) is incurred for each call on a dial-up circuit.

Local call.....11.17p
Duration (say < 1 min)..... 2.00p
volume (say 130 chars)..... 0.09p

Total 13.26p

Example 2 - Direct circuit

No call charges involved with a direct link to EIRPAC. However duration and volume charges apply as above.

Duration (say < 1 min)..... 2.00p
Volume (say 130 chars)..... 0.09p

Total2.09p

Note that annual rental on a dial-up link is £30, while a direct link costs £1100 per annum

APPENDIX V

SOME METEOROLOGICAL EQUIPMENT SUPPLIERS

Aanderaa. Instruments
Fanavefen 13
P. O. Box 160
5051 Bergen
Norway

Comprehensive Range

Phone: (Norway) 132500

UK Agent
W.S. Ocean Systems
Unit 101
Blackdown Industrial Estate
Haslemere
Surrey GU 27 3 BA
England.

Phone (0428) 54500

Campbell Scientific Ltd.
College Road
Sutton Bonington
Loughborough
Leics. LE 12, 5RA
UK

Data loggers and
Agricultural automatic
stations

Phone (05097) 2516

Delta-T Devices Ltd.
128 Low Road
Burwell
Camb. CB5 0EJ
UK

Agroclimatological Stations

Tel (0638) 742922
Telex 817670 "Att Delta - T"

Didcot Inst. Co. Ltd.
Unit 14
Thames View Industrial Park
Abingdon
Oxfordshire OX14 3UJ
England

Comprehensive Range

Phone: 0235-22345
Telex: 83343 ABTLX

Hollis Geosystems Corporation
11 Columbia Drive
Amherst N. H. 03031
U.S.A.

Automatic Weather
Stations

Phone: 603-882-5017
Telex: 953061 Hollis ob Nasu Cable Hollisobs

Wilh. Lambrecht GMBH
Postfach 2654, (Friedlander Weg 65-67)
D-3400 Göttingen
Fed. Rep. of Germany

Comprehensive Range

UK Agent

Wild Heerbrugg (UK) Ltd.
Revenge Road
Lordswood
Chatham
Kent ME5 8TE

Comprehensive Range

Tel (0634) 64471

Malling Kontrol
Stamholmen 173
Dk 2650 HVIDOVRE
Copenhagen
Denmark

Automatic Weather
Station

Phone: 01 490300
Telex: 19334 "Elmall Dk"

Metavia A.P.S. (Formerly Impulsfysik)
Ryttervaenget 38
3520 Farum
Denmark

Automatic Weather
Station

Phone: 16 045 (02) 952629
Telex: 055 37228

NBA Environmental Systems Ltd
Invincible Road
Farnborough
Hants GU14 7QU
UK

Automatic Weather
Stations

Obsermet (UK) Ltd
Unit 3 Springwood Court
Springwood Ind Estate
Rayne Road
Braintree
Essex CM7 7QX
UK

Comprehensive range

Vaisala Oy
PL 26
SF - 00421 Helsinki 42
Finland

Comprehensive range

Phone: 3580-890933
Telex: 122832 (VSALA-SF)

Vaisala (UK) Ltd.
Cambridge Science Park
Milton Road
Cambridge
Cambs CB4 4BH
UK

Comprehensive range

Phone (0223) 862112
Telex 817204

Ventureprise Co-op Ltd
Unit 9
Kensington Road
Coventry
Warwks CV5 6GG
UK

Agricultural Weather
Stations

Phone (0203) 714160
Telex 312444

Weather Measure USA (Weather measure
Weathertronicis)

Comprehensive range

P.O. Box 41039
Sacramento
California 95841

Phone: (916) 481 7563
(800) 824 5873

UK Agent

Weather Measure Services Ltd
The Old School House
15 Bulkington Road
Bedworth, Warwks CV12 9DG
England

Phone: (0203) 310359

Wintgens
Bureau Technique Wintgens SA
B 4700 Eupen
Belgium

Comprehensive range

Phone: 087-553921
Telex: 49258