

**Optimal use of immunomodulator  
and biological therapy in  
Inflammatory Bowel Disease**

A thesis submitted to the  
**University of Dublin**

In fulfilment for the degree of  
Doctor in Medicine (M.D.)  
September 2017

By  
Dr Donal Tighe  
MB BCh BAO

On research carried out with the  
**School of Medicine, Trinity College Dublin AND  
Department of Gastroenterology Tallaght  
Hospital**

Supervised by Professor Deirdre McNamara

# Declaration

I declare that this thesis has not been submitted as an exercise for a degree at this or any other university and it is entirely my own work. I agree to deposit this thesis in the University's open access institutional repository or allow the library to do so on my behalf, subject to Irish Copyright Legislation and Trinity College Library conditions of use and acknowledgement.

Signed

Trinity College Dublin Student Number: 15336910

Date

# Summary

Loss of response (LOR) to anti-TNF $\alpha$  therapy is a significant problem, and leads to increased hospitalisation rates, surgical intervention, and steroid dependency. Loss of response is multifactorial. However there is an increasing awareness that immunogenicity has a significant role to play in this process. Immunogenicity against anti-TNF $\alpha$  leads to antibody formation. Antibodies against anti-TNF $\alpha$  lead to faster drug clearance, as well as blocking drug activity. This culminates in a reduction in anti-TNF $\alpha$  trough levels and loss of response. Therapeutic drug monitoring (TDM) allows anti-TNF $\alpha$  trough and antibody levels, to be measured and doses adjusted or treatment switched, to help overcome loss of response and improve outcomes. This thesis aimed to explore the impact of loss of response to anti-TNF $\alpha$ , and accurately identify predictors of loss of response. In addition to investigate the role of therapeutic drug monitoring, in assessing and overcoming loss of response.

The main laboratory aspect of this thesis concerned the use of ELISA techniques, to accurately measure anti-TNF $\alpha$  trough and antibody levels. In brief a sandwich ELISA technique was used to detect anti-TNF $\alpha$  trough (infliximab & adalimumab) and antibody levels. ELISA microplates were coated with human TNF $\alpha$ . Horse radish peroxidase conjugated goat anti-human IgG Fc fragment antibody was added to serum samples, followed by diluted antibody. Substrate Solution tetramethylbenzidine (TMB) was added to each well, followed by the addition of stop solution. Drug concentrations in serum samples were determined using a standard curve generated from absorbance readings of infliximab or adalimumab.

One arm of this thesis looked at a retrospective cohort study, which confirmed the impact of loss of response to anti-TNF $\alpha$  therapy, with an overall LOR rate of 42.5% for a cohort on maintenance treatment one year after commencing therapy. In addition this

retrospective cohort study identified a number of key predictors of LOR, such as smoking, prior anti-TNF $\alpha$  therapy, as well as the protective benefits of combination therapy. Furthermore the link with biochemical response was confirmed, with a CRP <5 mg/L at the end of induction therapy being a significant predictor of clinical response.

The potential and usefulness of TDM was also explored in further detail. A retrospective study looked at the role of measuring anti-TNF $\alpha$  trough and antibody levels in a stand-alone fashion. Analysis did not identify a relationship, but there was evidence that patients with low trough levels, and loss of response, had higher biochemical markers of disease activity. Therefore further work was undertaken to establish a role for TDM at the key time-points of end of induction therapy, and during an assessment for secondary loss of response.

A prospective study looked at the role of TDM during induction therapy. There was a clear link between higher anti-TNF $\alpha$  trough levels at the end of induction with clinical response rates. For infliximab, mean trough levels in responders were 16.4  $\mu$ g/ml versus 5.3  $\mu$ g/ml for non-responders (p value = 0.026). Similarly there was a link between higher adalimumab levels and clinical response, though not statistically significant.

Secondary LOR to anti-TNF $\alpha$  therapy is multifactorial. TDM helps explore an immune basis behind it. A prospective study utilised TDM with dose intensification, introduction of immunomodulators or a switch in therapy resulting in improved response rates. This is part of an evolving therapeutic strategy to overcome LOR, in a patient focused clinically guided fashion. In conclusion TDM has an increasingly important role in the optimal, patient centred management of IBD.

# TABLE OF CONTENTS

<b>DEDICATION</b>	<b>1</b>
<b>ACKNOWLEDGEMENTS</b>	<b>2</b>
<b>LIST OF ABBREVIATIONS</b>	<b>4</b>
<b>LIST OF TABLES</b>	<b>6</b>
<b>LIST OF FIGURES</b>	<b>8</b>
<b>PUBLISHED PAPERS AND PRESENTATIONS</b>	<b>11</b>
PUBLICATIONS	11
PRESENTATIONS AT NATIONAL MEETINGS-ORAL	12
PRESENTATIONS AT NATIONAL MEETINGS	
-POSTER	12
PRESENTATIONS AT INTERNATIONAL MEETINGS	
-POSTER	13
GRANTS	13
AWARDS	14

<b>CHAPTER 1 – INTRODUCTION</b>	<b>15</b>
<b>1.1 Inflammatory Bowel Disease</b>	<b>15</b>
1.1.1 General Overview	15
1.1.2 Prevalence and Incidence	16
1.1.3 Pathology and clinical presentation	16
<b>1.2 Managing IBD-Treatment options</b>	<b>17</b>
1.2.1 General Overview	17
1.2.2 5-aminosalicylates and steroids	17
<b>1.3 Thiopurines in IBD</b>	<b>18</b>
1.3.1 Overview of thiopurines	18
1.3.2 Role for thiopurines in maintaining remission in IBD	19
1.3.3 Thiopurine Metabolic Pathway	20
1.3.4 Thiopurine associated toxicity	22
1.3.5 Interaction between 5-aminosalicylates and thiopurines	22
1.3.6 Genotyping and phenotyping for TPMT	23
1.3.7 Role for TPMT monitoring	23
1.3.8 Thiopurine metabolite monitoring	24
1.3.9 Difficulties with 6-TGN assay	25
<b>1.4 Anti-TNF<math>\alpha</math> therapy</b>	<b>26</b>
1.4.1 TNF $\alpha$	26

<b>1.4.2</b>	Infliximab, Adalimumab & Golimumab	26
<b>1.4.3</b>	Top-down versus bottom-up approach to managing IBD	28
<b>1.4.4</b>	Anti-TNF $\alpha$ therapy and Loss of Response	29
<b>1.4.5</b>	Defining Loss of Response	30
<b>1.4.6</b>	Aetiology of Loss of Response	30
<b>1.5</b>	<b>Immunogenicity, anti-TNF<math>\alpha</math> failure, and Therapeutic Drug monitoring</b>	<b>31</b>
<b>1.5.1</b>	Overview of anti-TNF $\alpha$ immunogenicity	31
<b>1.5.2</b>	Therapeutic Drug Monitoring	32
<b>1.5.3</b>	Defining anti-TNF $\alpha$ trough and antibody levels	33
<b>1.5.4</b>	Immunogenicity and bio-similiars	34
<b>1.5.5</b>	Anti-TNF $\alpha$ trough and antibody assays	34
<b>1.5.6</b>	Impact of immunogenicity on Loss of Response	36
<b>1.5.7</b>	Relationship between serum and intestinal anti-TNF $\alpha$ with levels of TNF $\alpha$	38
<b>1.5.8</b>	Link between anti-TNF $\alpha$ intensification and outcomes based on anti-TNF $\alpha$ trough and antibody levels	39
<b>1.5.9</b>	Economic benefit of Therapeutic Drug Monitoring	41
<b>1.5.10</b>	Therapeutic Drug Monitoring and monitoring	

toxicity	42
<b>1.5.11 Therapeutic Drug Monitoring and combination</b>	
therapy	42
<b>1.5.12 Therapeutic Drug monitoring facilitating drug</b>	
withdrawal	44
<b>1.5.13 Optimal anti-TNF<math>\alpha</math> trough levels</b>	45
<b>1.6 Therapeutic Drug Monitoring-Clinical application</b>	<b>49</b>
<b>1.6.1 Induction Phase</b>	49
<b>1.6.2 Maintenance Phase</b>	50
<b>1.6.3 Switching therapy</b>	51
<b>1.7 Goals of dissertation</b>	<b>52</b>
<b>CHAPTER 2 – General Materials &amp; Methods</b>	<b>54</b>
<b>2.1 Study Design</b>	<b>54</b>
<b>2.1.1 General Overview</b>	54
<b>2.1.2 Indications for Infliximab</b>	54
<b>2.1.3 Indications for Adalimumab</b>	55
<b>2.2 Disease Activity Scoring Systems</b>	<b>55</b>
<b>2.2.1 General Overview</b>	55
<b>2.2.2 Montreal Classification</b>	56



2.2.3	Harvey Bradshaw Index for Crohn’s Disease	57
2.2.4	Partial Mayo Score for Ulcerative colitis	58
2.2.5	Simple Endoscopic activity Score (SES-CD) for Crohn’s Disease	58
2.2.6	Mayo endoscopic sub-score for Ulcerative colitis	59
<b>2.3</b>	<b>Biochemical markers of inflammation and disease activity</b>	<b>60</b>
2.3.1	General Overview	60
2.3.2	Laboratory analysis of C-reactant protein and serum albumin	60
<b>2.4</b>	<b>ELISA methods for measuring anti-TNF<math>\alpha</math> trough and antibody levels</b>	<b>60</b>
2.4.1	General Overview	60
2.4.2	Specimen collection and handling	61
2.4.3	Preparation of reagents	61
2.4.4	Dilution of reagents	63
2.4.5	Plate coating and blocking- Detection of trough levels	63
2.4.6	Assay procedure- Detection of trough levels	64
2.4.7	Calculation of Results-Detection of trough levels	65
2.4.8	Plate coating and blocking	

-Detection of antibody levels	66
<b>2.4.9</b> Assay procedure- Detection of antibody levels	66
<b>2.4.10</b> Calculation of Results-Detection of antibody levels	66

## **CHAPTER 3 – Clinical and biochemical predictors**

### **of loss of response to anti-TNF $\alpha$ therapies in patients**

### **with inflammatory bowel disease. 68**

#### **3.1 Introduction 68**

#### **3.2 Aims 69**

#### **3.3 Materials and Methods 69**

#### **3.4 Results 71**

##### **3.4.1 Baseline Patient Characteristics 71**

##### **3.4.2 Clinical response at end of induction: Infliximab versus Adalimumab 73**

##### **3.4.3 Predictors of loss of response 74**

##### **3.4.4 Impact of combination therapy and prior anti-TNF $\alpha$ use on loss of response 76**

##### **3.4.5 Relationship between week 14 CRP and**

loss of response	76
<b>3.4.6</b> Sub-analysis of infliximab and adalimumab	
loss of response	77
<b>3.4.7</b> Week 14 CRP as a predictor of clinical response	80
<b>3.4.8</b> Serum albumin as a predictor clinical response	81
<b>3.4.9</b> Overall Outcomes	81
<b>3.5 Discussion</b>	<b>83</b>
<b>3.6 Conclusions</b>	<b>87</b>

**CHAPTER 4- One year follow up of an IBD cohort who previously have had anti-TNF $\alpha$  trough and antibody levels**

<b>assessed.</b>	<b>88</b>
<b>4.1 Introduction</b>	<b>88</b>
<b>4.2 Aims</b>	<b>90</b>
<b>4.3 Materials and Methods</b>	<b>91</b>
<b>4.4 Results</b>	<b>92</b>
<b>4.4.1</b> Baseline Patient Characteristics	92
<b>4.4.2</b> Sub-therapeutic anti-TNF $\alpha$ Trough Levels & Antibody Formation	94
<b>4.4.3</b> Mean anti-TNF $\alpha$ trough levels	96

<b>4.4.4</b>	One year Outcomes	96
<b>4.4.5</b>	Mean anti-TNFa trough levels, based on clinical outcomes	97
<b>4.4.6</b>	Relationship between mean CRP, albumin and clinical outcomes	98
<b>4.5</b>	<b>Discussion</b>	<b>99</b>
<b>4.6</b>	<b>Conclusions</b>	<b>103</b>

**CHAPTER 5- Positive relationship between infliximab and  
adalimumab trough levels at completion of induction therapy  
with clinical response** **104**

<b>5.1</b>	<b>Introduction</b>	<b>104</b>
<b>5.2</b>	<b>Aims</b>	<b>106</b>
<b>5.3</b>	<b>Materials and Methods</b>	<b>107</b>
<b>5.4</b>	<b>Results</b>	<b>108</b>
<b>5.4.1</b>	Baseline Patient Characteristics	108
<b>5.4.2</b>	Response rates at end of Induction therapy	111
<b>5.4.3</b>	Relationship between anti-TNFa trough levels with clinical response at end of induction therapy	113

<b>5.4.4</b>	Comparison of anti-TNF $\alpha$ trough levels between patients treated with and without immunomodulator combination therapy	116
<b>5.4.5</b>	Relationship between anti-TNF $\alpha$ trough levels with clinical activity scores and biochemical response	117
<b>5.4.6</b>	Level of anti-TNF $\alpha$ antibody formation	119
<b>5.4.7</b>	Therapeutic strategy at end of Induction therapy	119
<b>5.4.8</b>	Results at one year follow-up	121
<b>5.4.9</b>	Results of anti-TNF $\alpha$ dose intensification	124
<b>5.4.10</b>	Relationship between anti-TNF $\alpha$ trough and antibody levels, with dose intensification	127
<b>5.5</b>	<b>Discussion</b>	<b>128</b>
<b>5.6</b>	<b>Conclusions</b>	<b>133</b>

## **CHAPTER 6- Positive impact of therapeutic drug monitoring in assessing secondary loss of response to maintenance anti-TNF $\alpha$ therapy in inflammatory bowel disease**

<b>6.1</b>	<b>Introduction</b>	<b>134</b>
<b>6.2</b>	<b>Aims</b>	<b>138</b>

<b>6.3</b>	<b>Materials and Methods</b>	<b>138</b>
<b>6.4</b>	<b>Results</b>	<b>140</b>
<b>6.4.1</b>	Baseline Patient Characteristics	140
<b>6.4.2</b>	Mean adalimumab/infliximab trough and antibody levels at time of secondary loss of response	143
<b>6.4.3</b>	One year outcomes for patients assessed for secondary loss response to adalimumab	143
<b>6.4.4</b>	Comparison of adalimumab trough levels, clinical, biochemical and endoscopic scores between well/unwell groups at one year post secondary loss of response	145
<b>6.4.5</b>	One year outcomes for patients assessed for secondary loss of response to infliximab	148
<b>6.4.6</b>	Comparison of infliximab trough levels, clinical, Biochemical and endoscopic scores between unwell/unwell groups at one year post secondary loss of response	150
<b>6.4.7</b>	Therapeutic strategy chosen at time of secondary loss of response	150
<b>6.4.8</b>	Clinical outcomes for different therapeutic strategies	152

6.4.9	Outcomes for dose intensification group	152
6.4.10	Outcomes for switch group	154
6.5	<b>Discussion</b>	<b>157</b>
6.6	<b>Conclusions</b>	<b>160</b>
 <b>CHAPTER 7-General Discussion</b>		 <b>162</b>
7.1	<b>General Overview</b>	<b>162</b>
7.2	<b>Predictors of LOR</b>	<b>163</b>
7.2.1	Clinical predictors	163
7.2.2	Biochemical predictors	164
7.2.3	Smoking	164
7.2.4	Ileo-colonic disease phenotype	165
7.2.5	Clinical impact	165
7.3	<b>TDM stand alone/random assessments</b>	<b>165</b>
7.3.1	General Overview	165
7.3.2	Lack of correlation between random TDM and LOR	166
7.3.3	Relationship between trough levels, response rates and biochemical markers	166
7.3.4	Clinical impact	167

<b>7.4</b>	<b>Induction phase TDM and primary response</b>	<b>167</b>
7.4.1	Response at end of induction phase	167
7.4.2	Relationship between anti-TNFa trough levels and response rates	167
7.4.3	Optimal cut-off trough levels for infliximab and adalimumab	168
7.4.4	Benefits of combination therapy	168
7.4.5	Link between week 14 CRP and induction anti-TNFa trough levels	169
7.4.6	Anti-TNFa dose intensification post induction	169
<b>7.5</b>	<b>Targeted TDM at time of secondary LOR</b>	<b>169</b>
7.5.1	General Overview	169
7.5.2	Sub-therapeutic trough levels, and secondary LOR	170
7.5.3	Anti-TNFa trough levels and one year outcomes	170
7.5.4	Low ‘targeted’ trough levels in sustained LOR with high CRP	170
7.5.5	TDM, dose intensification, and switch in therapy	171
<b>7.6</b>	<b>Variations in immunogenicity and TDM between infliximab and adalimumab</b>	<b>172</b>



<b>7.7 Future Directions</b>	<b>173</b>
<b>CHAPTER 8-Conclusions</b>	<b>174</b>
<b>REFERENCES</b>	<b>176</b>



# **DEDICATION**

*For Catherine, Donnacha, & Sheenagh*

# ACKNOWLEDGEMENTS

This dissertation submitted for the degree of Doctor of Medicine, to the University of Dublin, describes the research work carried out in the School of Medicine, Trinity Health Centre, and Department of Gastroenterology, both at Tallaght Hospital, under the supervision of Professor Deirdre McNamara. Various individuals and organisations contributed to the successful completion of this work. Firstly, I am extremely grateful and thankful, to my supervisor Professor McNamara, for allowing me the opportunity to undertake this MD under her supervision and guidance. She has offered me immense support, advice, and insight throughout this project. Her research expertise, and knowledge, has proved invaluable for me. I can't thank her enough for all that she has done for me. I am indebted to her, for giving me this wonderful opportunity here.

I would also like to thank the other gastroenterology consultants at Tallaght Hospital, Dr Anthony O'Connor, Dr Niall Breslin, and Dr Barbara Ryan, for allowing me to recruit patients from their service, as well for their support, and enthusiasm that they have offered towards me. I am also grateful, to our IBD nurse specialists, Yvonne Bailey and Mary Kennedy, for all their help, patience and understanding. Thanks also to the other doctors, in the department, for assisting me with recruitment, and sample collection.

I am also grateful to our scientists, Sinead Smith and Denise Brennan for all their help in the lab. They have gone above and beyond, helping me in the scientific and laboratory aspects of my project. I thank them immeasurably for all their help.

Thanks also to our research assistant Claudio Tersaruolo for his enthusiasm and help, in aiding me in my research.

Thanks to everyone involved with our research group, the Trinity Academic Gastroenterology Group (TAGG), which provided me the perfect forum, to share ideas, discuss research questions, as well as presenting and reviewing my work on a weekly basis.

I am also grateful and proud of the financial support offered to me by the European Crohn's and Colitis Organisation (ECCO). They allowed me to pursue this project, and gave me the support and backing I needed to complete this work.

Thanks also to my fellow Lecturers in Clinical Medicine, at Tallaght Hospital, Catriona Gallagher and Abi Subramaniam for their patience and understanding, as I neared the end of this project.

Finally I would like to thank my wonderful family, for their unwavering support, love and patience throughout my period of research. 2 months in to the start of this research journey, we were blessed with the arrival of Donnacha and Sheenagh, my beloved twins, who have changed my world for the better. To Catherine, my darling wife, I am grateful to her for being by my side, and giving me the belief to finish this research journey.

# LIST OF ABBREVIATIONS:

IBD: Inflammatory Bowel Disease

GIT: Gastro-intestinal tract

CD: Crohn's disease

UC: Ulcerative colitis

TNF $\alpha$ : Tissue Necrosis Factor alpha

LOR: Loss of response

TDM: Therapeutic drug monitoring

5-ASA: 5-aminosalicylates

AZA: Azathioprine

6-MP: 6-Mercaptopurine

6-TGN: 6-thioguanine

TPMT: Thiopurine methyltransferase

6-MMP: 6-methyl-mercaptopurine

TIMP: Thionosine monophosphate

HGPRT: Hypoxanthine phosphoribosyl

MCV: Mean corpuscular volume

NAT1: N-acetyl transferase

IFX: Infliximab

ADL: Adalimumab

ADA: Antibodies against anti-TNF $\alpha$

ATI: Antibodies against Infliximab

AAA: Antibodies against Adalimumab

HBI: Harvey-Bradshaw index

SES-CD: Simple Endoscopic activity Score for Crohn's Disease

MES: Mayo endoscopy sub-score

STMH: Short term mucosal healing

ELISA: Enzyme linked immunosorbent assay

PBS: Phosphate buffered saline

BSA: Bovine serum albumin

HRP: Horseradish peroxidase

TMB: Tetramethylbenzidine

CRP: C-reactant protein

fL: femtolitres

CI: Confidence interval

RR: Relative risk

OR: Odds ratio

AUC: Area under the curve

ROC: Receiver operator curve

# LIST OF TABLES

Table 1.1: Detecting anti-TNF $\alpha$ trough levels.....	35
Table 1.2: Detecting anti-TNF $\alpha$ antibody levels.....	36
Table 1.3: Relationship between infliximab trough levels and response rates.....	37
Table 1.4: Relationship between adalimumab trough levels and response rates.....	38
Table 1.5: Strategies to overcome loss of response.....	40
Table 1.6: Trough levels associated with mucosal healing for infliximab.....	48
Table 1.7: Trough levels associated with mucosal healing for adalimumab.....	48
Table 2.1: Montreal Classification for Crohn’s disease.....	56
Table 2.2: Montreal Classification for extent of ulcerative colitis.....	56
Table 3.1: Baseline Patient Characteristics of predictors of LOR cohort.....	72
Table 3.2: Predictors of primary response/non response for patients treated with Infliximab/Adalimumab (pooled .data).....	75
Table 3.3: Predictors of primary response/non response for patients treated with Infliximab.....	77
Table 3.4: Predictors of primary response/non response for patients treated with Adalimumab.....	78
Table 4.1: Patient Baseline Characteristics for patients who had stand-alone anti-TNF $\alpha$ trough and antibody levels measured .....	93



Table 5.1: Baseline Patient Characteristics in cohort who had TDM performed at end of induction therapy.....	109
Table 5.2: Outcomes for anti-TNFa responders and non-responders at end of Induction therapy.....	112
Table 5.3: Therapeutic strategy for each group at end of induction therapy.....	121
Table 5.4: One year outcomes for cohort who had TDM performed at end of induction therapy.....	122
Table 5.5: Comparison of clinical, biochemical, endoscopic, TDM data for responders/non-responders to anti-TNFa dose escalation.....	125
Table 6.1: Baseline Patient Characteristics.....	140
Table 6.2: One year outcomes for patients assessed for secondary loss of response to adalimumab.....	143
Table 6.3: Patient characteristics of infliximab good and bad outcomes.....	149
Table 6.4: Therapeutic Strategy chosen at time of secondary loss of response assessment.....	151
Table 6.5: Comparison of clinical, biochemical, endoscopic, TDM data for responders/non-responders to anti-TNFa dose escalation.....	152
Table 6.6: Clinical, biochemical, endoscopic, TDM data for patients who had a switch in therapy.....	155

# LIST OF FIGURES

Figure 1.1: IBD related inflammation viewed at colonoscopy.....	15
Figure 1.2: Thiopurine Metabolic Pathway.....	21
Figure 1.3: Anti-TNF $\alpha$ molecule with binding site.....	27
Figure 2.1: ELISA ‘sandwich technique’ for measuring anti-TNF $\alpha$ trough & antibody levels (Roblin et al).....	66
Figure 2.2: ELISA microplate.....	64
Figure 2.3: EL-800 plate reader.....	65
Figure 3.1: Response rates for infliximab and adalimumab at end of induction and at one year follow up.....	74
Figure 3.2: Comparison of rates of loss of response between infliximab and adalimumab, by phenotype.....	80
Figure 3.3: Mean week 14 CRP based on anti-TNF $\alpha$ response rates.....	81
Figure 3.4: Outcomes of adalimumab non-responders post induction (one year follow-up).....	82
Figure 3.5: Outcomes of infliximab non-responders, post induction (one year follow-up).....	83
Figure 4.1: Patients on infliximab/adalimumab with low trough levels < 1 $\mu$ g/ml.....	95

Figure 4.2: Rates of antibody formation against infliximab and adalimumab.....	95
Figure 4.3: One year clinical outcomes for patients on maintenance infliximab/adalimumab.....	97
Figure 4.4: Mean trough levels for infliximab and adalimumab based on outcomes.....	98
Figure 4.5: Relationship between mean CRP, albumin and infliximab outcomes.....	99
Figure 5.1: Comparison of anti-TNFa trough levels, at end of induction between responders and non-responders.....	114
Figure 5.2: Infliximab levels, as predictor of clinical response at end of induction.....	115
Figure 5.3: Adalimumab levels, as predictor of clinical response at end of induction.....	115
Figure 5.4: Comparison of mean anti-TNFa trough levels between those treated with/without combination therapy.....	117
Figure 5.5: Change in CRP for anti-TNFa responders and non-responders at end of induction therapy.....	118
Figure 5.6: Comparison in rates of week CRP <5 mg/L at end of induction therapy between anti-TNFa responders and non-responders.....	119
Figure 5.7: Patient flow chart.....	120
Figure 5.8: Relationship between mean anti-TNFa trough levels at induction, with one	

year outcomes.....	124
Figure 5.9: Comparison of change in mean CRP levels post anti-TNFa intensification between responder and non-responders.....	127
Figure 6.1: Relationship between anti-TNFa trough levels, with 1 year outcomes to infliximab and adalimumab, in patients assessed for secondary loss of response.....	146
Figure 6.2: Mean CRP for infliximab and adalimumab 1 year outcomes, in patients evaluated for secondary loss of response.....	147
Figure 6.3: Adalimumab trough levels, as a predictor of clinical response for patients experiencing secondary LOR.....	148
Figure 6.4: Change in mean CRP in patients post anti-TNFa dose intensification, responders versus non-responders (secondary LOR cohort).....	154
Figure 6.5: Comparison of Adalimumab trough levels, between Switch and Dose intensify groups.....	156
Figure 6.6: Comparison of antibody formation between Switch and Dose intensify groups (Adalimumab).....	156

# PUBLISHED PAPERS AND PRESENTATIONS

Part of this thesis has been published and/or presented in both national and international conference meetings as follows:

## Publications

1. **Tighe D**, McNamara D. Clinical impact of immunomonitoring in the treatment of inflammatory bowel disease. *World J Gastroenterol*. 2017 Jan 21;23(3):414-425. Review
2. **Tighe D**, Hall B, Jeyarajah SK, Smith S, Breslin N, Ryan B, McNamara D. One year follow up of an IBD cohort who previously have had anti-TNF $\alpha$  trough and antibody levels assessed. *Inflamm Bowel Dis*. 2017 Jul;23(7):1154-1159
3. **Tighe D**, Smith S, O'Connor A, Breslin N, Ryan B, McNamara D. Positive relationship between infliximab and adalimumab trough levels at completion of induction therapy with clinical response rates at a tertiary referral centre. *Journal of Gastroenterology & Hepatology Open*, 1: 4–10. doi:10.1002/jgh3.12000

## **PRESENTATIONS AT NATIONAL MEETINGS-ORAL**

1. **Tighe D**, Hall B, Jeyarajah SK, Smith S, Breslin N, Ryan B, McNamara D. Evaluation of the clinical efficacy of Anti-TNF- $\alpha$  drug trough and antibody levels in an Irish Inflammatory bowel disease cohort. **Irish Society of Gastroenterology Winter Meeting, Dublin, November 2015**

## **PRESENTATIONS AT NATIONAL MEETINGS-POSTER**

1. **Tighe D**, Breslin N, Ryan B, McNamara D. Clinical/biochemical predictors of response to anti-TNF $\alpha$  therapies in a tertiary referral centre. **Irish Society of Gastroenterology Summer Meeting, Galway, June 2016**
2. **Tighe D**, Smith S, O'Connor A, Breslin N, Ryan B, McNamara D. Correlation Of Relationship Between Infliximab And Adalimumab Trough And Antibody Levels With Clinical Response Rates At Completion Of Induction Therapy. **British, Ulster & Irish (BIG) Gastroenterology Meeting, Belfast , April 2017 (First prize poster presentation)**

# **PRESENTATIONS AT INTERNATIONAL MEETINGS-POSTER**

1. **Tighe D**, Breslin N, Ryan B, McNamara D. Clinical/biochemical predictors of response to anti-TNF $\alpha$  therapies in a tertiary referral centre. **European Crohn's and Colitis Organisation (ECCO) Conference, Barcelona February 2017.**
2. **Tighe D**, Smith S, O'Connor A, Breslin N, Ryan B, McNamara D. Positive relationship between infliximab and adalimumab trough levels at completion of induction therapy with clinical response rates at a tertiary referral centre. **United European Gastroenterology Week (UEGW), Barcelona, November 2017**
3. **Tighe D**, Hession R, Azizi N, Smith S, O'Connor A, Breslin N, Ryan B, McNamara D. Positive impact of therapeutic drug monitoring in assessing secondary loss of response to maintenance anti-TNF $\alpha$  therapy in inflammatory bowel disease. **United European Gastroenterology Week (UEGW), Barcelona, November 2017**

## **GRANTS**

1. European Crohn's and Colitis Organisation (ECCO). To promote innovative scientific research in IBD in Europe. Awarded at the 11<sup>th</sup> ECCO Congress, Amsterdam, The Netherlands, March 2016.

# AWARDS

1. O'Morain Research Medal awarded by Meath Foundation. 'Role of therapeutic drug monitoring in optimising IBD. Received at Grand Rounds, Tallaght Hospital, June 23<sup>rd</sup> 2017.



# CHAPTER 1-INTRODUCTION

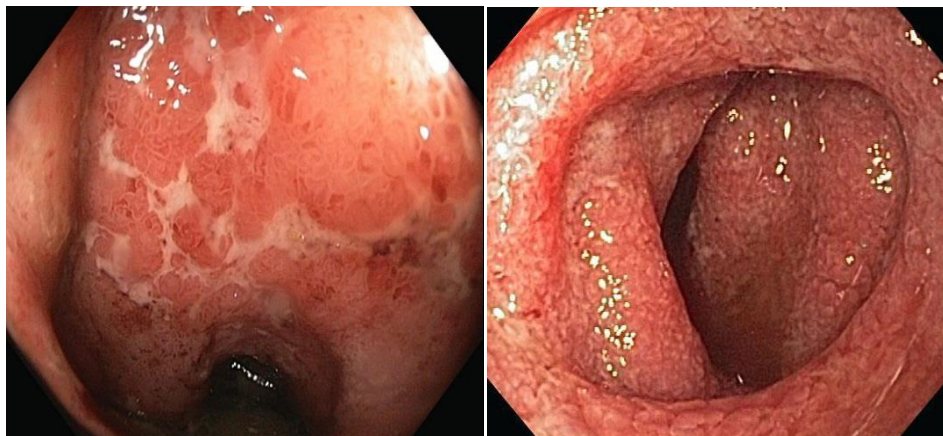
## 1.1 Inflammatory Bowel Disease

### 1.1.1 General Overview

Inflammatory Bowel Disease (IBD) is a chronic, relapsing and remitting disorder of the gastrointestinal tract (GIT). It is composed of two distinct phenotypes; Crohn's disease (CD) characterised by segmental inflammation (**Figure 1.1**) that can occur anywhere throughout the GIT and Ulcerative colitis (UC), where inflammation is confined to the large bowel. It is diagnosed, on the basis of clinical, radiological, endoscopic and histological criteria.

The aetiology of IBD is poorly understood. Dysregulation of the body's adaptive and innate immune system, as a result of some external environmental factor, in genetically predisposed individuals is likely the main driving factor [1]. Alterations in the body's microflora, may act as a trigger that stimulates the pro-inflammatory cascade that drives IBD [2].

**Figure 1.1: IBD related inflammation viewed at colonoscopy**



## **1.1.2 Prevalence and Incidence**

The incidence of IBD can vary throughout the world. There is a clear tendency to a higher incidence in developed countries compared to less developed countries [3]. The incidence of IBD is highest in North America, North Western Europe and Scandinavia [3]. From the paediatric literature there appears to be a significant increase in new cases throughout the world, with the appearance of a more aggressive and severe phenotype, particularly for Crohn's disease. A Finnish study for example, has shown that the mean annual incidence of paediatric IBD has increased from 7/100,000 for the years 1987-1990 to 23/100,000 for the years 2011-2014 [4]. From an Irish perspective, recent work has further illustrated this, with an increase in early onset paediatric IBD (<10 years) [5]. The authors have also found that males have more extensive and severe disease phenotypes, and younger patients have higher relapse rates than older children. In addition there is evidence of an increased incidence of very early onset (VEO-IBD), and a link with mutations in Interleukin 10 receptor [6]. Such patients suffer with more extra-intestinal manifestations, as well as severe peri-anal penetrating disease phenotypes.

## **1.1.3 Pathology and clinical presentation**

CD related inflammation may occur throughout the gastrointestinal tract, from the mouth to perianal areas, whereas the inflammation in UC is confined to the large bowel [7]. There is a clear pathological distinction between the two conditions, with CD characterised by transmural rather than superficial mucosal inflammation and by skip lesions, with quite often rectal sparing, rather than continuous disease [7]. However in clinical practice this pathological distinction can be less clear, which can influence the decision making process around the use of biological therapy, and the need for surgical

intervention. Overtime the transmural nature of CD can lead to fibrogenesis and scar formation, and to the development of obstructive clinical presentations, which are quite distinct from the inflammatory manifestations of UC [8]. The most common inflammatory symptoms include: diarrhoea, crampy abdominal pain, bleeding, fever and weight loss. In addition CD is associated with penetrating complications, which can result in the development of fistulating tracts, typically perianal, entero-entero, enterovesical, enterovaginal or entero-cutaneous [9].

## **1.2 Managing IBD-Treatment options**

### **1.2.1 General Overview**

The spectrum of IBD varies from mild disease confined to the rectum, managed relatively easily in the community, to complicated stricturing and penetrating Crohn's disease that may require multiple surgeries, and or potent immunosuppressive regimens. Thus treatment options in IBD are dependent on the disease phenotype, the location and severity of inflammation [10].

### **1.2.2 5-aminosalicylates and steroids**

Mild disease may be managed with topical or oral aminosalicylates (sulfasalazine, mesalamine). They may induce remission in over 90% of cases of mild to moderate proctitis/rectosigmoiditis [11]. Their mode of action is centred on the large bowel, and it is thought they exert their actions through anti-inflammatory or some mild immunosuppressive processes [12]. However more severe inflammation will require glucocorticoids to induce remission [13]. Long term however they are not a good option for maintaining remission, due to concerns about steroid related side effects, like diabetes mellitus, avascular necrosis of the hip, osteoporosis, and adrenal insufficiency.

Hence the need for alternative agents like immunomodulators (thiopurines, methotrexate), and novel anti-Tissue Necrosis Factor alpha (TNF $\alpha$ ) biological therapies (infliximab, adalimumab), to achieve and maintain remission.

## **1.3 Thiopurines in IBD**

### **1.3.1 Overview of thiopurines.**

Thiopurines like azathioprine (AZA) and its pro-drug 6-mercaptopurine (6-MP) have been used for decades for the maintenance of remission in IBD [14-15]. These drugs have effective absorption from the GIT. However they are slow to take effect, and it could be up to three months before optimal therapeutic benefits are felt. There is long-term data, which demonstrates that they are unsuccessful in inducing remission in the acute setting [16]. They are therefore not an option for induction of remission.

Historically they were used as immunosuppressants in the management of lymphoproliferative disorders, as well as being used as anti-rejection agents in the setting of solid organ transplantation. They interfere with folate metabolism, a key component of DNA synthesis. Expanding on this, the active metabolite 6-thioguanine (6-TGN), may accumulate in lymphocytes, and interrupt the inflammatory cascade that drives IBD. It is thought it blocks the actions of these pro-inflammatory cytokines, such as TNF-related apoptosis inducing ligand [17].

### **1.3.2 Role for thiopurines in maintaining remission in IBD**

Thiopurines have a role as mentioned in maintaining remission in both UC and CD. Typically they will be utilised alongside steroids in the induction phase of treatment [18]. Studies have demonstrated a role for maintaining remission in CD, with greatest benefit noticed at higher doses 2-2.5mg/kg, and a greater likelihood of steroid free remission, compared to placebo. They are typically used in the setting of steroid refractory or dependent disease [19]. They also have some role in reducing recurrence post-surgery for ileal CD. A meta-analysis has shown the thiopurines are more beneficial than placebo or aminosalicylates for maintaining remission in the post-operative patient [20]. However the recent TOPPIC study looking at a role for thiopurines in the post-operative period, found that mercaptopurine was effective only in smokers, in reducing post-operative clinical recurrence [21].

Thiopurines are also used in combination with anti-TNF $\alpha$  biological therapies, for optimal clinical effect. Increased adoption of a 'top-down' approach has seen their earlier introduction for more complex and aggressive disease phenotypes. The SONIC trial data has shown that the combination of infliximab and azathioprine is superior to infliximab alone for the induction and maintenance of remission in early Crohn's disease [22]. AZA may be commenced at low doses (to counteract some GIT upset) and titrated to a maximum therapeutic dose of 2-2.5mg/kg. 6-MP should be used at doses 50% of AZA, due to differences in molecular weight of the two agents.

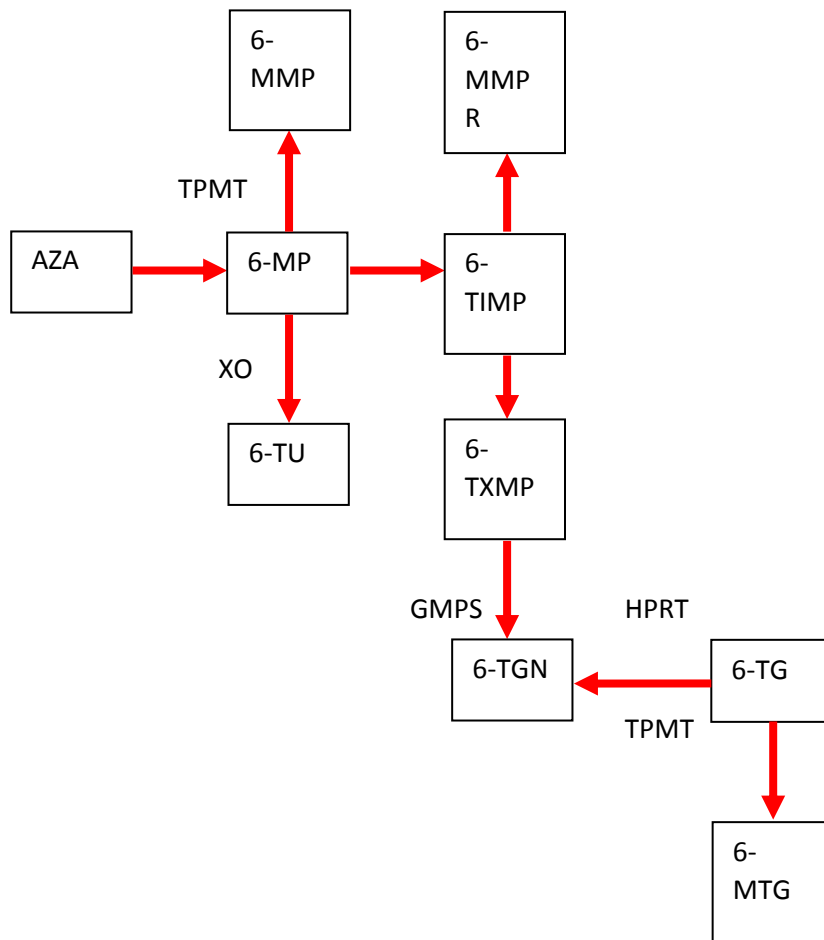
It's worth noting, however the more limited evidence base for the use of thiopurines in ulcerative colitis. Compared to Crohn's disease, there are fewer higher quality controlled studies in UC. Indeed some authors, feel that there isn't enough evidence to

justify the use of azathioprine alone, or in combination with 5-ASA's, compared to 5-ASAs alone for the maintenance of remission in UC [23].

### **1.3.3 Thiopurine Metabolic Pathway**

The metabolic pathway involving thiopurines is complicated, resulting in formation of active and inactive complexes (**Figure 1.2**). Understanding this pathway though is essential to recognising potential toxicity issues, as well as maximising therapeutic benefits for patients. Following absorption from the GIT, AZA may be metabolised by different enzymatic pathways. It may be converted to 6-thiouric acid by xanthine oxidase. Methylation by Thiopurine methyltransferase (TPMT) into 6-methyl mercaptopurine (6-MMP) may occur which can be associated with hepatotoxicity. Finally it may be converted to thioinosine monophosphate (TIMP) by hypoxanthine phosphoribosyl (HGPRT). This metabolite is finally converted into the active metabolite of the drug, 6-thioguanine (6-TGN). However in excess, typically greater than 400pmol, it can be associated with bone marrow toxicity

**Figure 1.2: Thiopurine Metabolic Pathway**



Thiopurine metabolism: Oral AZA is rapidly converted to 6-MP by a nonenzymatic process. Initial 6-MP transformations occur along competing catabolic (XO = xanthine oxidase, producing 6-thiouric acid [6-TU]; TPMT = thiopurine methyltransferase) and anabolic (HPRT = hypoxanthine phosphoribosyltransferase) enzymatic pathways. Once formed, 6-thiosine 5'-monophosphate (6-TIMP) may be transformed either into 6-TGN by the rate-limiting inosine monophosphate dehydrogenase (IMPDH) and guanosine monophosphate synthetase (GMPS) enzymatic pathways or methylated into 6-methyl mercaptopurine ribonucleotides (6-MMPR). Initial 6-TG transformations occur along two competing metabolic pathways. The anabolic HPRT pathway converts 6-TG

directly to 6-TGN. The competing catabolic (TPMT) pathway yields minimal concentrations of methylated thioguanine nucleotides (6-methyl thioguanine [6-MTG]).

### **1.3.4 Thiopurine Associated toxicity**

As mentioned the enzymatic pathway of thiopurines is complicated, and there is potential for formation of harmful metabolites that may lead to unwanted hepatotoxicity and bone marrow suppression. TPMT catalyses one of the rate limiting enzymatic pathways of AZA. There can be significant individual variability with regard to TPMT activity, and this can have a consequence for adverse side effects and toxicity. Therefore there is a role for assessing TPMT activity prior to introduction of thiopurine based therapies, and indeed some guidelines recommend that this be considered a standard of care [24]. Patients who are deficient in TPMT are prone to accumulation of 6-TGN to toxic levels, and increased risk of bone marrow suppression.

However the relationship is not concrete and myelosuppression may take place, even in the absence of TPMT gene mutations [25]. Thus close monitoring for potential toxicity is required regardless. In addition, there is evidence that very high levels of 6-TGN found in neutrophils, with undetectable levels of 6-MMPR, in comparison to those found in red blood cells, may explain the specific neutropenic/leucopenic adverse effect of AZA [26].

### **1.3.5 Interaction between 5-aminosalicylates and thiopurines**

Further work recently has revealed some interesting interaction between aminosalicylates and thiopurines. Co-administration of 5-ASA's is associated with an increase in 6-TGN levels [27]. A recent study has shown that carriers of NAT 1(N-



acetyl transferase) genotype could influence 6-TGN levels in patients prescribed 5-ASA's and thiopurines, with effects on response rates and side effects [28]. Although a small study it raises interest for further study on polymorphisms and the impact of 5-ASAs on thiopurine metabolites.

### **1.3.6 Genotyping and phenotyping for TPMT**

Genotyping of TPMT has shown that 89% of individuals are homozygous for the wild type (WT) gene, and are high TPMT metabolisers. 10% are heterozygous and 1 in 300 is homozygous for low TPMT metabolic polymorphism [29]. Thus these patients are at risk of toxicity, and the use of thiopurines here needs to be strongly reconsidered. In addition TPMT enzyme activity (phenotype) may be calculated and patients may be subdivided into high, intermediate or low TPMT metabolisers, with again low metabolisers having elevated levels of 6-TGN [30]. This is of concern when such patients are treated with standard doses of AZA.

### **1.3.7 Role for TPMT monitoring**

The utilisation of TPMT activity in clinical practice varies depending on guidelines. Some organisations, which are strongly in favour of measuring TPMT advise against introduction of thiopurines, in those with the homozygous allele, and favour a gradual step wise increase in doses, titrated to a weight based schedule [31]. Another approach is to favour introduction of thiopurines at the maximum desired therapeutic dose, with close monitoring after its commencement. There is no evidence that such an aggressive approach is more advantageous. Indeed studies have shown that intravenous administration of AZA is no better than standard oral administration [32]. A recent Dutch study looked at the relationship between TPMT mutation variants and toxicity.

They found that screening for mutation variants in TPMT did not reduce the proportions of patients with haematological adverse side effects during thiopurine treatment for IBD. However, the study did show a 10-fold reduction in hematologic side effects among TPMT mutation carriers who were identified and received a dose reduction, compared with TPMT mutation carriers who did not, without differences in treatment efficacy [33].

### **1.3.8 Thiopurine Metabolite Monitoring**

Metabolite monitoring of thiopurines can serve two main functions. Firstly it allows dose titration for optimal clinical effect and also for monitoring of potential drug toxicity. 6-TGN is the active metabolite of thiopurines, and a level of greater than 230 pmol has been associated with remission in IBD population [34]. In addition a 2006 meta-analysis showed that the mean/median 6-TGN levels were higher among patients in remission than in those with active IBD (pooled difference, 66 pmol/8 x 10<sup>8</sup> red blood cells; 95% confidence interval (CI), 18-113; p = .006), but with significant heterogeneity. Patients with 6-TGN levels above the threshold value were more likely to be in clinical remission (62%) than those below the threshold value (36%) (pooled odds ratio, 3.3; 95% confidence interval, 1.7-6.3; p < .001), but with again significant heterogeneity [35]. In addition a recent study has confirmed that an adjustment of AZA doses based on 6-TGN levels resulted in improved clinical efficacy and reduced toxicity compared to the standard weight based adjustment protocol [36].

As mentioned TPMT activity may predict 6-TGN levels. A recent study has shown that a higher BMI is associated with reduced 6-TGN levels, and increased 6-MMP levels. This may explain some of the reasons for worse outcomes in IBD patients with obesity. The exact mechanism requires further study [37].

### **1.3.9 Difficulties with 6-TGN assay**

Despite the potential of 6-TGN metabolite monitoring, there have been difficulties encountered limiting its widespread use as part of the routine monitoring of patients on azathioprine therapy. The majority of assays involve measuring red blood cell (RBC) TGNs by using a high performance liquid chromatography assay [38]. This approach can be time consuming and involves the need to process samples in a timely fashion, limiting the ability to bank or store specimens. In addition there are some concerns about reproducibility of 6-TGN assays [39]. Compliance with immunomodulators is also a concern, however metabolite monitoring does offer an objective method, of ensuring patients, are adhering to their treatment regimen. [40]. It's clear therefore, there is a need for more convenient and accurate assays in order to incorporate 6-TGN metabolite monitoring fully into clinical practice. One alternative, involves an indirect measure of 6-TGN levels, by way of measuring blood mean corpuscular volume (MCV). A study by Decaux et al found a strong correlation between delta MCV and 6-TGN levels, ( $r = 0.74$ );  $P < .001$ ), in a study of 43 patients, treated with azathioprine, who weren't anaemic [41]. The lack of a significant increase in MCV after 3 to 4 months of AZA therapy reflects low 6-TGN levels, sometimes a result of under treatment. The authors observed that delta MCV could be used as an indicator of 6-TGN levels after 6 months of AZA treatment. An increase in MCV of at least 6 fL is expected to reflect a 6-TGN level of about 175 pmol/ $8 \times 10^8$  red blood cells (probably being within a therapeutic value).

## **1.4 Anti-TNF $\alpha$ therapy**

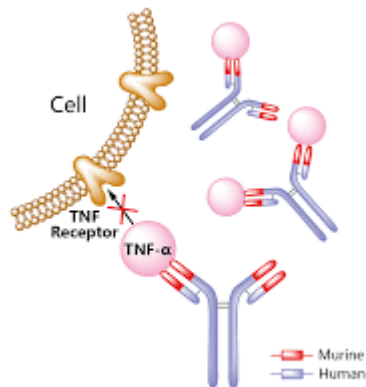
### **1.4.1 TNF $\alpha$**

Tissue Necrosis Factor alpha (TNF) is central to the inflammatory cascade that drives IBD. It is therefore no surprise that antibodies that directly target TNF have dramatically changed the management of luminal and fistulating Crohn's disease, as well as the inflammatory process that characterises moderate to severe ulcerative colitis. Secreted by Th1 cells, TNF $\alpha$  is elevated in patients with IBD [42]. It is highly localized to the intestinal mucosa and lumen. Studies have shown high concentrations of TNF $\alpha$  localising to the intestinal tissue and stool of patients with IBD [43-44]. The three main stays of anti-TNF $\alpha$  therapy licensed for use in IBD patients are infliximab, adalimumab and golimumab, which will be discussed briefly in the following sections.

### **1.4.2 Infliximab, Adalimumab & Golimumab**

Infliximab (IFX) is an IgG1 chimeric mouse/human monoclonal antibody (**Figure 1.3**), with proven efficacy in the management of luminal and fistulating Crohn's disease and severe UC [45]. It consists of a human Fab' fragment combined with a murine Fc fragment. Adalimumab (ADL) is a fully human recombinant IgG1 monoclonal antibody target again against TNF alpha, with proven efficacy for induction and remission in both CD and UC [46-47]. Both agents are successful for inducing and maintaining remission. Infliximab is commenced as an intravenous infusion at a standard induction regimen of 5mg/kg at weeks 0, 2 and 6, followed by regular maintenance treatment at every 8 weeks. ACT 1 and ACT 2 trial data in UC have demonstrated efficacy of IFX in inducing remission in moderate to severe disease compared to placebo [48].

**Figure 1.3 Anti-TNF $\alpha$  molecule with binding site**



Adalimumab has proven efficacy in both achieving and maintaining remission in both CD and UC. ULTRA 1 and 2, trial data confirmed efficacy for ADL in inducing and maintain remission [49]. Similar to infliximab there is a role for treating fistulating disease. ADL is administered in subcutaneous form, with an induction regimen of 160mg week 0, 80mg week 2, and 40mg every fortnight thereafter. There are theoretical concerns about the impact of subcutaneous administration of anti-TNF $\alpha$  agents on absorption rates. There are perceived increased risks of antibody formation, following this mode of administration, but to date, there haven't been overwhelming evidence in the literature to suggest this [50].

Golimumab, is a subcutaneously administered, fully human anti-TNF $\alpha$  antibody, with proven efficacy for the induction and maintenance of remission in ulcerative colitis. The PURSUIT-SC study, showed in phase 3 trials, that the rates of clinical response at week 6 were 51.0% and 54.9% among patients given 200 mg/100 mg and 400 mg/200 mg golimumab, respectively, vs 30.3% among those given placebo (both,  $P \leq .0001$ ) [51]. A follow-up study has shown that golimumab helped maintain remission in patients who responses to induction therapy, for those with moderate to severe UC [52]. There is no efficacy for patients with Crohn's disease.

### **1.4.3 Top-down versus bottom-up approach to managing IBD**

Historically there has been a step wise escalation of therapies, using a ‘bottom up’ approach with a gradual escalation in therapies, as inflammation progressed. However there has been a recent body of evidence that strongly suggests a more aggressive, ‘top down’ approach with the earlier introduction of immunosuppressive agents, to alter the natural history of the condition, dampen down inflammation, and achieve mucosal healing. Post hoc analysis from the sentinel anti-TNF $\alpha$  trials has shown that earlier introduction of anti-TNF $\alpha$  within 3 years of diagnosis was associated with greater therapeutic response compared to a delayed introduction [53]. In addition there are certain scenarios where anti-TNF $\alpha$  therapy is strongly indicated as front line therapy, such as the use of rescue infliximab in the setting of acute severe ulcerative colitis, when patients have failed standard treatment with corticosteroids [54]. Furthermore, anti-TNF $\alpha$  therapy is considered the gold standard in managing penetrating and fistulating complications of Crohn’s disease [55].

In addition, treatment aims have changed since the introduction of anti-TNF $\alpha$  therapy. There is move away from the idea of focusing on clinical endpoints, towards more robust evidence of mucosal healing, which has been shown to help predict sustained clinical remission [56]. Expanding on this, there has been recent discussion about the concept of deep or complete remission, which involves achieving both endoscopic and histological remission, to help alter the natural history of the disease. A recent study by Bryant et al, explored this concept. 91 patients with UC were followed up for a median 72 months (IQR 54-75 months) [57]. Overall, concordance between endoscopic and histological remission was moderate ( $\kappa=0.56$ , 95% CI 0.36 to 0.77);

24% patients had persistent inflammation despite endoscopic remission. Histological remission predicted corticosteroid use and acute severe colitis requiring hospitalisation over the follow-up period (HR 0.42 (0.2 to 0.9),  $p=0.02$ ; HR 0.21 (0.1 to 0.7),  $p=0.02$ ; respectively), whereas endoscopic mucosal healing did not (HR 0.86, 95% CI 0.5 to 1.7,  $p = 0.65$ ; HR 0.83 95% CI 0.3 to 2.4,  $p= 0.74$ ; respectively). The authors conclude that histological remission is a target distinct from endoscopic mucosal healing in UC and helps better predict lower rates of corticosteroid use, and acute severe colitis requiring hospitalisation. This study supports the idea of including histological indices in both UC clinical trials and practice, and a move towards a target of 'complete remission'. The use of anti-TNF $\alpha$  therapy is likely to increase further, to achieve these more concrete targets.

#### **1.4.4 Anti-TNF $\alpha$ therapy and Loss of response**

Anti-TNF $\alpha$  therapies have revolutionised the management of IBD, improving response rates, and helping to alter the natural history of the disease and achieve, long term goals of mucosal healing and deep remission. However loss of response (LOR) and immunogenicity is a big concern. 80% of patients treated with infliximab in CD respond initially, but overtime 30% of patients will lose response, requiring dose and interval adjustments [58-59]. LOR is associated with flares of disease, increased hospitalisation rates, need for surgical interventions, and decline in quality of life. Historically doses have been intensified in a stepwise fashion, based on clinical response. This standard approach involves increasing the doses of anti-TNF $\alpha$  used, and shortening frequency of administration. For example, for infliximab, dose may be

increased to 10mg/kg, or infusion interval shortened to 4 or 6 weekly intervals. For adalimumab, the dose may be escalated to 40mg every week.

### **1.4.5 Defining Loss of Response**

As mentioned overtime response to anti-TNF $\alpha$  therapy can be lost, leading to treatment failure. LOR may be primary or secondary. There are difficulties around strict definitions for LOR [60]. Primary LOR refers to the situation, whereby patients fail to respond to anti-TNF $\alpha$  during or at the end of standard induction therapy, typically up to 12-14 weeks. Secondary LOR refers to the scenario where patients initially respond to anti-TNF $\alpha$  therapy, but overtime gradually lose response. LOR for both infliximab and adalimumab occurs in 23–46% of CD patients at 12 months post anti-TNF $\alpha$  initiation, when assessed by the need to dose-intensify. The incidence can vary between 7–25% if measured by the rate of anti-TNF $\alpha$  discontinuation [61-62]. Patients may experience a reduced or a diminished clinical response. This can be associated with a flare of symptoms, need for further steroid exposure, and further IBD related complications.

### **1.4.6 Aetiology of Loss of Response**

It's important when evaluating patients with LOR, to consider alternative aetiologies. For example non-IBD related factors, such as infection, or functional symptoms like irritable bowel syndrome. Furthermore there are certain situations, where the non-inflammatory attributes of IBD can lead to an increase in symptoms, and presumed anti-TNF $\alpha$  failure. For example, fibrostenotic disease is unlikely to respond adequately to anti-TNF $\alpha$  therapy [63-64]. However there is increasing recognition, that there may be a significant immune basis behind LOR to anti-TNF $\alpha$  therapy, Anti-TNF $\alpha$



itself may be involved, through the impact of anti-TNF $\alpha$  drug pharmacokinetics, pharmacodynamics and immunogenicity.

## **1.5 Immunogenicity, anti-TNF $\alpha$ failure and Therapeutic Drug Monitoring**

### **1.5.1 Overview of anti-TNF $\alpha$ immunogenicity**

Overtime the body's immune system may recognise anti-TNF $\alpha$  molecules, as foreign antigens, and result in antibody formation against them. This process is called immunogenicity, and can result in increased drug clearance and subsequent loss of response. Antibodies against anti-TNF $\alpha$  (ADA) formation can lead to failure of anti-TNF $\alpha$  which may be due to a change in pharmacokinetics causing a faster clearance or by blocking the drug's activity in case of neutralizing ADA. Therefore, drug trough concentrations could be the missing link to help understand the clinical impact of ADA [65]. Caution though is required, due to the knowledge that not all ADA are functional, and further studies are required to explore the significance of non-functioning ADA [66].

As mentioned above, Infliximab is a chimeric mouse-human IgG1 molecule and antibodies to IFX (ATIs) are directed against the murine F(ab)<sub>2</sub> fragment of the drug. Antibodies may form against infliximab in a large number of patients (8-60%), and indeed may form as soon as after the first infusion [59]. Immunogenicity is associated with increased drug clearance, which directly leads to reduced trough levels. This can ultimately lead to loss of response, infusion reactions and the need for dose intensification, or the need to switch to an alternative agent. A two-compartment

pharmacokinetic model for infliximab has shown that the clearance increases 2.7-fold in patients positive for ATI'S as compared with patients without ATI'S [67].

## **1.5.2 Therapeutic drug monitoring**

Therapeutic drug monitoring (TDM) is the use of laboratory techniques to measure anti-TNF $\alpha$  drug and antibody levels. Historically using a standard approach, drug doses are adjusted based on clinical need. However this approach is not patient focused, and doesn't explore the underlying pharmacokinetics of anti-TNF $\alpha$  therapy. A treat to target approach with the use of anti-TNF $\alpha$  drug and antibody levels, could help tailor treatment to the individual and may help improve response rates, overcome loss of response, and achieve mucosal healing. An example of this approach used to good effect, is from the recent TAXIT study, whereby patients infliximab doses were proactively intensified if trough levels were <3ug/ml [68].

Key issues at present concerning the role of TDM include defining optimal trough levels, as well as clarifying why low trough levels develop, and the need to formulate strategies to improve them. In addition, there is a need to ascertain whether higher troughs are required to help achieve mucosal healing. Furthermore questions around clinically significant and insignificant antibody levels, need to be addressed. The role for combination therapy, and its impact on immunogenicity, also needs to be clarified. Other important issues, include determining when best to check trough and antibody levels, with perhaps strong consideration to targeting the period around completion of induction therapy. Finally improvement in laboratory ELISA techniques, reproducibility, and comparability of different assays, also requires attention. These questions and issues will be explored in the following sections.

### **1.5.3 Defining anti-TNF $\alpha$ trough and antibody levels**

As mentioned immunogenicity leads to ADA formation, and sub-therapeutic anti-TNF $\alpha$  trough levels, which can lead to loss of response. It's important to define targets when incorporating TDM into the treatment algorithm of IBD. Low trough levels, are defined as trough levels <1 $\mu$ g/ml. The trough represents the lowest concentration reached by a drug, prior to its next administration. The treat to target approach, involves aiming for optimal rather than minimal anti-TNF $\alpha$  trough levels. Therapeutic trough levels are currently being redefined, and targets will likely be drug specific, and trough levels will need to be improved, to achieve mucosal healing.

Concerns have been expressed about the risk of high or supra-therapeutic trough levels. A recent study however has shown IBD patients with higher anti-TNF $\alpha$  serum concentrations had significantly better disease-specific quality-of-life. Fatigue, arthralgia, skin lesions and other side-effects do not occur more often in these patients. This study is reassuring in that high serum concentrations of anti-TNF $\alpha$  are not toxic [69].

Antibody formation to TNF $\alpha$  is not a fixed process. A prospective study of 125 patients with IBD, treated with infliximab showed that ATI formation can fluctuate [70]. Clinically relevant ATI were typically formed within the first 12 months but transient ATI, which are of little clinical significance, can be formed at any time during treatment. LOR can be predicted based on a combination of C-reactant protein (CRP), trough levels and stable antibodies with a high degree of accuracy [66]. Transient antibody formation is not associated with a loss of response.

### **1.5.4 Immunogenicity and Bio-similiars**

Recently there has been an introduction of biosimilar anti-TNF $\alpha$  molecules for treating IBD. European agencies have approved Remsima, Inflectra and Flixabi (CT-P13) for use in Europe across all indications [71]. A recent study has confirmed the cross-reactivity of Remsima and Remicade (infliximab) suggesting similar immunodominant epitopes and immunogenic potential of the two agents [72]. It confirms that patients with IBD who develop high-titre antibodies and infusion reaction/loss of response to Remicade should probably not be considered for switching to Remsima. In contrast, patients who develop anti-adalimumab antibodies may be considered for a switch to either Remicade or Remsima, if clinically indicated.

### **1.5.5 Anti-TNF $\alpha$ trough and antibody assays**

There are a number of different ways of measuring drug concentration of anti-TNF $\alpha$  molecules in serum. For convenience trough levels are measured. The most commonly used method is enzyme-linked immunosorbent assay (ELISA) [73-74]. The advantage of monoclonal or monospecific polyclonal anti-drug antibody is the specificity toward the anti-TNF $\alpha$  drug, which results in lower specific binding [75]. This reduces the risk of false positives.

With regard to detecting ADA the most commonly used assay is the double-antigen (a.k.a. bridging) ELISA in which the anti-TNF $\alpha$  drug is both used as capture and detecting antibody [76]. Despite developments and improvements in the assays to measure anti-TNF $\alpha$  and ADA levels, there is still a lack of standardization and quality control between the established tests [77]. This can have clinical implications, as well as issues around reproducibility of results between different centres.

A number of factors can influence ADA formation, including the type of assay used, timing involved in antibody measurement as well as the study population. Taking this into account there have been attempts to standardize measurements, specifically for ADA against adalimumab [78].

ELISA techniques whilst reproducible and accurate do not offer single patient testing. Ongoing research is looking at more rapid turnaround alternatives. Lu et al have developed a fast bioassay for determining IFX concentration in serum using an in-house developed fiber-optic surface plasmon resonance (FO-SPR) biosensor [79]. The assay turn-around time, was considerably reduced compared to ELISA.

**Tables 1.1 and 1.2**[74, 76-85] illustrate the different options available in terms of measuring anti-TNF $\alpha$  trough and antibody levels. Measuring ADA has proved problematic, and there are ongoing attempts to develop drug tolerant ELISA assays.

**Table 1.1 Detecting anti-TNF $\alpha$  trough levels.**

Study	Technique	Key Points
Ternant <i>et al</i> [74]	ELISA	
Vande Casteele <i>et al</i> [77]	ELISA	
Lu <i>et al</i> [79]	FO-SPR based sandwich bioassay	Faster than ELISA, correlates well
Malíčková <i>et al</i> [80]	ELISA (for CT-P13 biosimilar to infliximab)	
Corstjens <i>et al</i> [81]	Rapid lateral flow (LF)-based assay	
Wang <i>et al</i> [82]	Non-radiolabeled homogeneous mobility shift assay (HMSA)	

ELISA: Enzyme-linked immunosorbent assay; FO-SPR: Fiber-optic surface plasmon resonance

**Table 1.2: Detecting anti-TNF $\alpha$  antibody levels.**

Ref.	Technique	Key points
Van Stappen <i>et al</i> [83]	Solid-phase ELISA	Lacks the ability to detect ADA in the presence of drug
Gils <i>et al</i> [78]	Solid-phase ELISA	
Bloem <i>et al</i> [84]	Drug tolerant ELISA	
Imaeda <i>et al</i> [76]	ELISA	Measures AAAs in the presence of free ADA
Van Stappen <i>et al</i> [85]	ELISA	Converts drug-sensitive bridging ELISA into a drug-tolerant bridging ELISA

ELISA: Enzyme-linked immunosorbent assay; ADA: Anti-tumor necrosis factor- $\alpha$ ; AAA: Antibodies against adalimumab.

### 1.5.6 Impact of immunogenicity on Loss of Response

As mentioned above antibody formation against anti-TNF $\alpha$  is associated with LOR. In general low trough levels (<1 $\mu$ g/ml) and the presence of detectable antibodies are associated with worse clinical outcomes. Steenholdt *et al* established a cut off of <0.5 $\mu$ g/ml, which has been associated with LOR [86]. It's clear that the level of anti-TNF $\alpha$  will impact on response rates, and there is ample evidence that higher trough levels are associated with sustained response, and likewise low or undetectable trough levels, increase the likelihood of LOR. The following table from published papers explores the current evidence of the relationship between infliximab trough levels and loss of response (**Table 1.3**) [86-95]. Studies by Yamada *et al* [88] and Pariente *et al* [89] both showed higher trough levels in patients who lost response, compared to those

that maintained response, although not statistically significant. No major methodological issues were apparent to explain these findings. The data for adalimumab is somewhat more limited (Table 1.4) [96-97].

**Table 1.3: Relationship between infliximab trough levels and response rates.**

Ref.	N	Mean IFX trough levels $\mu\text{g/ml}$	Mean IFX trough levels $\mu\text{g/ml}$	P value
		Lost response	Maintained response	
Ainsworth <i>et al</i> [87]	27	0 (0-0.1)	2.9 (0.9-4.3)	0.002
Yamada <i>et al</i> [88]	31 (CD)	6.3	4.7	NS
Steenholdt <i>et al</i> [86]	69 (CD)	N/A	2.8 (0.8-5.3)	< 0.0001
Pariente <i>et al</i> [89]	76 (CD)	3.3 $\pm$ 4.1	2.3 $\pm$ 2.2	NS
Steenholdt <i>et al</i> [86]	13 (UC)	N/A	3.8 (1.1-8.5)	< 0.0001
Karmiris <i>et al</i> [90]	136 (CD)	0.3 (0.3-3.6)	4.9 (1.7-8.2)	0.01
Marits <i>et al</i> [91]	79 (CD)	1.8	4.1	< 0.001
Bortlik <i>et al</i> [92]	84 (CD)	N/A	> 3	N/A
Adedokun <i>et al</i> [93]	728 (UC)	N/A	3.7	N/A
Cornillie <i>et al</i> [489]	147 (CD)	1.9	4.0	0.0331
Reinisch <i>et al</i> [95]	203 (CD)	0.8	2.14	0.006

IFX: Infliximab; UC: Ulcerative colitis; CD: Crohn's disease.

**Table 1.4: Relationship between adalimumab trough levels and response rates.**

Study	N	Mean Adalimumab trough levels $\mu\text{g/ml}$	Mean Adalimumab trough levels $\mu\text{g/ml}$	P value
		Lost response	Maintained response	
Imaeda <i>et al</i> [96]	40 (CD)	N/A	5.9	N/A
Roblin <i>et al</i> [97]	40 (UC/CD)	3.2	6.2	0.12

In addition, to ADA formation the inflammatory burden may impact on response to anti-TNF $\alpha$ . For example, Brandse *et al* have shown that in UC, patients with more severe disease lose infliximab in stool, to a greater level than clinical responders [98]. This emphasises the concept of the leaky, inflamed gut, with increased loss of anti-TNF $\alpha$  in severely inflamed tissue. This links in with further research by Gibson *et al*, showing increase response rates and reduced colectomy rates in patients treated with an accelerated induction course of infliximab for severe UC [99]. Going forward, it will be useful to check trough levels, during this accelerated protocol, to further define the best treatment strategy for severe UC.

### **1.5.7 Relationship between serum & intestinal anti-TNF $\alpha$ with levels of TNF $\alpha$**

The ATLAS study has explored the relationship between serum and intestinal anti-TNF $\alpha$  levels, with endoscopic disease activity and levels of TNF $\alpha$  [100]. This study of a cross-sectional group of 30 patients with UC or CD, treated with IFX or ADL showed that anti-TNF $\alpha$  levels were higher in mild to moderately inflamed than in non-inflamed



tissue, but this increase was more than negated by the proportionally greater level of TNF in inflamed tissue. Anti-TNF $\alpha$  concentration in tissue correlated with degree of endoscopic inflammation, except for tissue with severe inflammation in which anti-TNF $\alpha$  levels were again lower (mean normalised anti-TNF $\alpha$  in tissue: uninflamed=0.93, mild=2.17, moderate=13.71, severe=2.2 inflammation (p=0.0042)). This may explain why patients with satisfactory anti-TNF $\alpha$  levels, have active disease, as the inflamed tissue characterised by an abundance of TNF $\alpha$  acts as a sink for the anti-TNF $\alpha$ . This in turn increases the risk of ADA formation. These patients might therefore benefit from drug dose intensification.

Going forward more work is required to tease out the distinction between clinically significant and insignificant ADA, which undoubtedly has a big impact on loss of response.

Finally as mentioned previously one must also consider alternative explanations for loss of response. Overlap with functional symptoms, small bowel bacterial malabsorption, non-inflammatory strictures, could all explain alternatives to immunogenicity, in causing loss of response.

### **1.5.8 Link between anti-TNF $\alpha$ dose intensification and outcomes based on trough and antibody levels**

TDM has an increasingly important role to play in managing IBD. A prospective examination of a cohort in The Netherlands has shown absence of IFX-trough levels in a significant proportion of their population, suggesting a vital role for TDM, in identifying and managing loss of response to anti-TNF $\alpha$  therapies [101].

As mentioned LOR is a big concern with anti-TNF $\alpha$  therapy. TDM has a role to play in helping to explore the pharmacokinetics behind LOR and to develop strategies to overcome it. For example, if patients have low trough levels, and no ADA, they may benefit from dose intensification, whereas patients, with adequate trough, and no ADA, are unlikely to benefit. Furthermore in the setting of ADA, and low trough, one strategy is the use of combination therapy, to reduce ADA and improve trough levels. However in the setting of ADA, and adequate trough levels, intensifying doses, will have no impact and a drug switch should be considered (**Table 1.5**). There is increasing evidence that adaption of a treat to target approach, with dose intensification based on anti-TNF $\alpha$  trough and antibody levels, alongside appropriate treatment selection, helps improve response rates, and achieve mucosal healing.

**Table 1.5: Strategies to overcome loss of response.**

		<u>Trough Level</u>	
		Low	High
<u>Antibodies</u>	Present	Alternative anti-TNF	Add Immunomodulator
	Absent	Dose Escalate	Consider alternative cause for symptoms or alternative agent

There is now evidence, that dose escalation of anti-TNF $\alpha$  based on low drug trough levels, not only leads to improved clinical response rates, but also to increased

mucosal healing. The TAXIT study as mentioned briefly above looked at patients on stable maintenance doses of infliximab in remission and adjusted their infliximab dose to obtain a fixed drug level between 3-7µg/ml [68]. This resulted in a higher proportion of CD patients in remission than before dose escalation (88% vs. 65%;  $P = .020$ ). This approach was also cost-effective, with 72 patients with trough levels  $>7$  µg/ml, 67 patients (93%) achieved trough levels of 3-7 µg/ml after dose reduction. This resulted in a 28% reduction in drug cost from before dose reduction ( $P < .001$ ).

In addition a recent study has also shown that a therapeutic week 2 IFX trough level is associated with higher likelihood of mucosal healing in a UC population [102].

### **1.5.9 Economic Benefit of Therapeutic Drug Monitoring**

A Danish study by Steenholdt also confirms that an individualised approach, with adjustment of infliximab doses based on drug antibody and trough levels, is more cost effective, without any obvious negative clinical effect on efficacy [103]. Costs for intention-to-treat patients were substantially lower (34%) for those treated in accordance with the algorithm than by IFX dose intensification: € 6038 vs. € 9178,  $p < 0.001$ . However, disease control, as judged by response rates, was similar: 58% and 53%, respectively,  $p = 0.81$ ; difference 5% (-19% to 28%). For per-protocol patients, treatment costs were even lower (56%) in the algorithm-treated group (€ 4062 vs. € 9178,  $p < 0.001$ ) and with similar response rates (47% vs. 53%,  $p = 0.78$ ; difference -5% (-33% to 22%)). Similarly a study by Velayos et al, has confirmed that a test based strategy is more effective, than empiric dose escalation, for a cohort of patients with Crohn's disease treated with infliximab [104]. The testing strategy yielded similar quality adjusted life years compared with the empiric strategy (0.801 vs 0.800, respectively) but was less expensive (\$31,870 vs \$37,266, respectively).

### **1.5.10 Therapeutic drug monitoring and monitoring toxicity**

In addition TDM can be utilised to manage complications or drawbacks to anti-TNF $\alpha$  therapy. As well as impacting on loss of response, anti-TNF $\alpha$  antibody formation is also associated with transfusion related reactions and anaphylaxis [105]. For example patients with ATI are at increased risk of acute transfusion reaction, and loss of response, compared to those patients without ATI [106]. In addition a study by Baert et al, in which an arbitrary figure for ATI was used in a population with CD, they showed that patients with an ATI greater than 8 $\mu$ g/ml had increased risk of loss of response, and 2.4 fold increased risk of infusion reaction [73].

### **1.5.11 Therapeutic drug monitoring and combination therapy**

There is ample evidence that the addition of an immunomodulator like a thiopurine or methotrexate to anti-TNF $\alpha$  therapy is associated with improved response rates in IBD. In the SUCCESS (Efficacy and Safety of Infliximab, as Monotherapy or in Combination with Azathioprine, versus Azathioprine Monotherapy in Moderate to Severe Ulcerative Colitis) trial in UC, steroid-free remission was achieved by 40% of patients receiving infliximab and azathioprine, compared with 22% receiving infliximab alone (P=0.017) [107]. Furthermore it has been shown that combination therapy of infliximab and azathioprine is associated with reduced infliximab antibody formation, as well as reduced systemic inflammation. Post hoc analysis of the SONIC trial data has shown that at week 30, trough levels for the combination of IFX and AZA were 3.5  $\mu$ g/ml versus 1.6  $\mu$ g/ml for the IFX group alone (p<0.001). The authors also

found that only 1 out of 116 (0.9%) in the combination group had drug antibodies compared to 15 out of 103 (14.6%) in the IFX group alone [22]. Combination therapy has been shown to require less need for dose escalation, surgical intervention or the need for switching to a different class of ant-TNF or alternative agents.

In addition data from a Dutch study has confirmed the benefits of combination therapy in overcoming the problems of immunogenicity [108]. In a study involving 217 patients (108 patients IFX; 109 patients' adalimumab), mean trough levels in the IFX group was higher in the combination therapy group compared with the monotherapy group, 4.6 versus 7.5  $\mu\text{g/ml}$ ,  $P = 0.04$ . In the ADL group, the difference was not significant. In patients with IFX monotherapy, the incidence of antibody formation was higher compared with patients with combination therapy (29.8% versus 5.7%,  $P = 0.001$ ). The incidence of antibody formation was lower in IFX patients who immediately started with immunomodulators compared with patients who did not (33.3% versus 66.7%,  $P = 0.04$ ). Thus combination therapy, through a synergistic effect on immunogenicity clearly results in reduced antibody formation, and leads to a greater likelihood of improved response rates. There are concerns, about increased risk of complications and malignancy, using a combination therapy approach, particularly in younger males [109]. However a recent large meta-analysis of over 11,000 patients, doesn't suggest that anti-TNF $\alpha$  or immunomodulators increase the risk of extra-colonic cancer [110].

As mentioned above there is also role for measuring 6-TGN levels, the active metabolite of azathioprine [34]. This offers the potential to even further optimise the combination approach. An interesting study by Yarur et al looked at the relationship between 6-TGN, infliximab trough and antibody levels [111]. They performed a cross-sectional study of 72 patients receiving maintenance therapy with infliximab and a

thiopurine for IBD. They found that levels of 6-TGN correlated with those of infliximab ( $\rho$ , 0.53;  $p < .0001$ ). The cut-off point of 6-TGN that best predicted a higher level of infliximab was 125 pmol/ $8 \times 10^8$  red blood cells (RBCs)  $p < .001$ ). Patients with 6-TGN levels less than 125 pmol/ $8 \times 10^8$  RBCs were significantly more likely to have ATI (odds ratio, 1.3; 95% CI, 2.3-72.5;  $p < .01$ ). Historically a 6-TGN level 230 pmol/ $8 \times 10^8$  RBCs have been associated with better response rates in patients on monotherapy, a level of 6-TGN of 125 pmol/ $8 \times 10^8$  RBCs or greater may be adequate to achieve therapeutic levels of infliximab. In the long term, this may minimize the toxicity and adverse side effects, like malignancy for patients on combination therapy.

However as discussed measuring 6-TGN levels is complicated, with concerns over reproducibility of the assay, as well as the potential for increased toxicity, in patients with high 6-TGN levels. This may restrict the wide-spread use of 6-TGN monitoring, as part of the treatment algorithm.

### **1.5.12 Therapeutic drug monitoring facilitating drug withdrawal**

The benefits of combination therapy are proven, with improved response and remission rates. There is however long terms concerns about the side-effects of combination therapy, and concerns expressed about risks of lymphoproliferative disorders in particular. Therefore discussions about withdrawal of immunomodulators in well patients, achieving remission have been debated. Concerns have been expressed though about relapse of disease with their withdrawal. In a retrospective study, among co-treated patients, levels of infliximab remained stable after immunomodulators were withdrawn after at least 6 months of therapy (before: 3.2  $\mu\text{g/ml}$ ; 95% CI, 1.6-5.8  $\mu\text{g/ml}$

and after: 3.7 µg/ml; 95% CI, 1.3-6.3 µg/ml; p = .70) [112]. The most striking observation in this study was the fact that none of the 27 patients with infliximab trough levels >5 µg/ml at the time of immunomodulator withdrawal lost response to infliximab after withdrawal of immunomodulator during the median follow-up of 29 months. The authors propose that it is safe to stop immunomodulators in patients with IFX trough levels greater than 5 µg/ml.

### **1.5.13 Optimal Anti-TNF $\alpha$ trough levels.**

As mentioned above the use of anti-TNF $\alpha$  trough and antibody levels, may be helpful in identifying loss of response. Also of interest is the potential to develop strategies to improve response rates. However there is a need to define optimal trough levels, in terms of what's required not only to achieve clinical remission, but also what's necessary for achieving mucosal healing. As mentioned the TAXIT study, looking at patients who have secondary loss of response to infliximab doses can be safely intensified aiming for a trough level of between 3-7 µg/ml [68].

Similarly Bortlik et al [92] showed that an infliximab trough of greater than 3 µg/ml, at the start of a maintenance regime was associated with sustained clinical response to infliximab. A recent meta-analysis by Moore et al [113] has shed further light on optimal targets for infliximab. They found twelve studies reported IFX levels in a manner suitable for determining effect estimates. During maintenance therapy, patients in clinical remission had significantly higher mean trough IFX levels than patients not in remission; 3.1 µg/ml vs. 0.9 µg/ml. Patients with an IFX level > 2 µg/ml were more likely to be in clinical remission (Relative Risk (RR) = 2.9, 95% CI: 1.8-4.7, p < 0.001), or achieve endoscopic remission (RR = 3, 95% CI: 1.4-6.5, p = 0.004) than patients with levels < 2 µg/ml.

In addition evidence is emerging that in order to achieve the more stringent target of mucosal healing, higher trough levels are essential. **Table 1.6** [95-96, 114-117] illustrates the data for infliximab trough levels and mucosal healing, and **Table 1.7**, the data for adalimumab.

In a French study looking at response to infliximab dose intensification in patients losing response, the only factor associated with a greater likelihood of mucosal healing, was an increase in drug trough levels [114]. A recent meta-analysis by Barnes et al [118] showed that among patients with IBD, anti-TNF $\alpha$  trough levels above pre-specified values were associated with increased rates of mucosal healing (OR = 5.57, 95%CI: 3.80-8.15).

In a retrospective study of 145 IBD patients Ungar et al [116] recently found significant association between serum levels of anti-TNF $\alpha$  agents and level of mucosal healing. Median serum levels of infliximab and adalimumab were significantly higher in patients with mucosal healing than patients with active disease (based on endoscopy) (for infliximab, 4.3  $\mu$ g/ml vs. 1.7  $\mu$ g/ml,  $p = 0.0002$  and for adalimumab, 6.2  $\mu$ g/ml vs. 3.1  $\mu$ g/ml,  $p = 0.01$ ). Levels of infliximab above 5  $\mu$ g/ml (area under the curve = 0.75,  $p < 0.0001$ ) and levels of adalimumab above 7.1  $\mu$ g/ml (area under the curve = 0.7,  $p = 0.004$ ) identified patients with mucosal healing with 85% specificity. Increasing levels of infliximab beyond 8  $\mu$ g/ml produced only minimal increases in the rate of mucosal healing, whereas the association between higher level of adalimumab and increased rate of mucosal healing reached a plateau at 12  $\mu$ g/ml. They propose that serum levels of 6-10  $\mu$ g/ml for infliximab and 8-12  $\mu$ g/ml for adalimumab are required to achieve mucosal healing in 80%-90% of patients with IBD, and that this could be considered as a "therapeutic window". Exceeding these levels produces only a negligible gain in proportion of patients with mucosal healing. Further studies are



required, but this suggests, that in order to alter the natural history of IBD, and achieve mucosal healing, we need robust and sustained trough levels of anti-TNF $\alpha$ .

With regard to adalimumab there is less available research in the field of TDM. Post-hoc analysis of the Karmiris trial by Baert et al [119] has shown that a low serum adalimumab concentration after the induction regimen increases the risk of AAA formation. A trough level of  $< 5 \mu\text{g/ml}$  increased the risk of AAA formation. In addition AAA formation is associated with a future risk of inflammation and disease relapse. Further analysis of the CHARM trial data also identified a positive association between serum adalimumab concentration and remission at several time points [120]. However the authors did not identify a threshold concentration reliably associated with remission. Roblin et al [97] also showed that in a cohort of 40 patients with IBD, on maintenance therapy, trough levels of adalimumab were higher in patients with mucosal healing ( $6.5 \mu\text{g/ml}$ ) than in patients without ( $4.2 \mu\text{g/ml}$ ,  $p < 0.005$ ). Zittan et al [121] similarly showed that higher adalimumab trough levels are associated with mucosal healing. In a cohort of 60 patients, on maintenance adalimumab therapy, a median trough of  $14.7 \mu\text{g/ml}$  was found in those with mucosal healing vs.  $3.4 \mu\text{g/ml}$  in those without,  $p = 6.25 \times 10^{-5}$ ). They propose a cut-off of  $8.14 \mu\text{g/ml}$ , be used, as a target to achieve mucosal healing.

**Table 1.6: Trough levels associated with mucosal healing for infliximab.**

Study	n	Mean Infliximab Trough level µg/ml	Mean Infliximab Trough level µg/ml	P value	95%CI
		Mucosal Healing	No mucosal Healing		
Paul <i>et al</i> [114]	52 (UC/CD)	Delta IFX > 0.5		0.0001	
Ungar <i>et al</i> [116]	78 (UC/CD)	4.3	1.7	0.002	
Imaeda <i>et al</i> [96]	45 (CD)	> 4.0			0.56-0.70
Reinisch <i>et al</i> [95]	123 (CD)	> 3.0			1.53-7.28
Colombel <i>et al</i> [117]	188 (CD)	3.51	1.72	0.0018	
Papamichael <i>et al</i> [115]	101(UC)	> 15 (wk 6)		0.025	
		> 2.1 (wk 14)		0.004	

IFX: Infliximab; UC: Ulcerative colitis; CD: Crohn's disease.

**Table 1.7: Trough levels associated with mucosal healing for adalimumab.**

Study	n	Mean Adalimumab Trough level µg/ml	Mean Adalimumab Trough level µg/ml	P value
		Mucosal Healing	No mucosal Healing	
Ungar <i>et al</i> [116]	67 (UC/CD)	6.7	3.1	0.01
Roblin <i>et al</i> [97]	40 (UC/CD)	6.5	4.2	< 0.05

Study	n	Mean Adalimumab Trough level $\mu\text{g/ml}$	Mean Adalimumab Trough level $\mu\text{g/ml}$	P value
		Mucosal Healing	No mucosal Healing	
Zittan <i>et al</i> [121]	60 (UC/CD)	14.7	3.4	< 0.0001

UC: Ulcerative colitis; CD: Crohn's disease.

## 1.6 Therapeutic Drug Monitoring-Clinical application

### 1.6.1 Induction Phase

The time-period at the completion of anti-TNF $\alpha$  induction therapy, is a critically important phase. Low anti-TNF $\alpha$  trough levels, in the induction phase are linked to increase risk of antibody formation for both infliximab and adalimumab [122-123]. Data though on optimal trough levels at induction phase is limited. However a recent Belgian study of 101 patients with UC, who completed induction therapy with infliximab, has demonstrated that higher infliximab trough levels, are associated with increased likelihood of short term mucosal healing [115]. Multiple logistic regression analysis identified infliximab concentration  $\geq 15 \mu\text{g/ml}$  at week 6 (p=.025; odds ratio, 4.6; 95% C.I. 1.2-17.1) and  $\geq 2.1 \mu\text{g/ml}$  at week 14 (p=.004; odds ratio, 5.6; 95% C.I., 1.7-18) as independent factors associated with short term mucosal healing. In addition a recent study by Yarur *et al* has looked at optimal trough levels, required to treat more aggressive phenotypes, like penetrating Crohn's disease [124]. In a cohort of 117 CD patients with perianal fistulating disease, patients with fistula healing had significantly

higher median serum infliximab levels when compared to those with active fistulas [15.8 vs. 4.4 µg/ml, respectively ( $P < 0.0001$ ). Achieving infliximab levels  $\geq 10.1$  µg/ml in patients with Crohn's disease and perianal fistulas may improve outcomes as part of a treat-to-target strategy. Further randomised studies are required, but this suggests that a targeted approach, achieving therapeutic trough levels after completion of induction phase of therapy, will help optimise response and remission rates.

Brandse et al, have also shown significant differences in IFX trough levels at 6 weeks in responders compared to non-responders, after completion of induction course of IFX [125]. The median serum concentrations of infliximab at week 6 were 8.1 µg/ml in responders (interquartile range, 3.0-13.7 µg/ml) and 2.9 µg/ml in nonresponders (interquartile range, 0.01-5.8 µg/ml) ( $p = .03$ ). In addition they found that early development of ATIs during induction therapy reduces the serum concentration of infliximab, and is associated with nonresponse to treatment. Patients with high baseline serum levels of CRP had lower serum concentrations of infliximab. Clearly the risk of immunogenicity is a concern from the outset of treatment, and particularly for the severely inflamed colon, an accelerated induction course with therapeutic trough levels are essential to best optimise response rates.

## **1.6.2 Maintenance Phase**

With regard to the maintenance phase of treatment, there is evidence from the literature backing up a targeted approach to therapy. As mentioned the TAXIT study, looked at patients on maintenance infliximab, who were randomised either to a treat to target approach, aiming for trough levels between 3-7µg/ml, and the current standard approach. During optimization stage response rates were improved in patients with sub-therapeutic levels, who had their IFX doses intensified. In addition patients with supra-

therapeutic levels had doses safely reduced, allowing a more cost effective use of anti-TNFa [68].

### **1.6.3 Switching Therapy**

Despite attempts to optimise response to anti-TNFa therapy, some patients will require a switch to another agent within the anti-TNFa family, as well as alternative biologic agents, or immunomodulators. Patients with adequate trough levels, who lose response, are unlikely to benefit from further dose escalation. In a study of 247 IBD patients, with suspected loss of response, trough levels of adalimumab greater than 4.5 µg/ml and infliximab greater than 3.8 µg/ml identified patients who failed to respond to an increase in drug dosage or a switch to another anti-TNF agent with 90% specificity [126]. This was a heterogenous cohort, with both adult and paediatric patients included. In addition levels of antibodies against adalimumab >4 µg/ml or antibodies against infliximab >9 µg/ml identified patients who did not respond to increase in doses of anti-TNFa, with 90% specificity. The authors also propose that different trough levels, may be required for different IBD phenotypes.

Switching from one class on anti-TNFa to an alternative agent is associated with modest response rates. It's worth noting that patients who develop antibodies to one anti-TNFa agent are more likely to develop antibodies to an alternative anti-TNFa agent. For example Fredriksen et al has shown that in patients who failed infliximab, antibody formation to adalimumab was increased which was associated with minimal drug level, and a clear lack of response [127]. They propose that it is prudent to assess ADL immunogenicity in anti-IFX Antibody-positive switchers to ensure optimal interventions at inadequate treatment responses and to avoid inappropriate ADL intensification regimens. In addition data from the SWITCH trial has shown that

elective switching to a subcutaneous regimen is not efficacious and is associated with a high likelihood of losing response [128].

In patients with ADA's and low anti-TNF $\alpha$  trough levels, consideration can be given to alternative anti-TNF $\alpha$  agents, like golimumab, or newer agents, like vedolizumab. Vedolizumab, is an alpha 4-beta 7 integrin inhibitor targeting a different pathway in the inflammatory cascade, is newly licensed for use in CD and UC. There is emerging evidence that TDM may help predict early LOR and facilitate dose intensification to ensure more optimal and sustained response. In an observational study of 47 patients treated with vedolizumab, week 6, trough levels <18.5  $\mu\text{g/ml}$  were associated with need for extended therapy (additional dose of vedolizumab at week 10) (100% positive predictive value, 46.2%; negative predictive value; area under the receiver operating characteristic curve, 0.72) within the first 6 months [129]. More studies are required though to confirm the role of TDM in newer agents.

## **1.7 Goals of dissertation**

The overall objectives and aims of this dissertation are:

1. To ascertain the optimal approach in the management of IBD using anti-TNF $\alpha$  therapy and immunomodulators.
2. To explore the impact that loss of response to anti-TNF $\alpha$  therapy has on patient outcomes.
3. Identify clinical and biochemical predictors of LOR, which will help better identify patients, who are more likely to respond to anti-TNF $\alpha$  therapy.

As mentioned LOR can be multifactorial, but there is increasing awareness and focus on the impact of immunogenicity against anti-TNF $\alpha$  therapy. This dissertation also aims to:

1. Explore the specific immune basis behind LOR.
2. Identify a relationship between anti-TNF $\alpha$  trough and antibody levels, with clinical response rates at both induction and during maintenance therapy.
3. Clarify if anti-TNF $\alpha$  trough and antibody levels are more informative than biomarkers, like CRP

Therapeutic drug monitoring as discussed, has an emerging role in addressing LOR and helping to improve overall response rates. This dissertation will look at the role of TDM, across a number of key time-points in the management of IBD:

1. Maintenance phase, 'stand-alone' anti-TNF $\alpha$  trough & antibody levels
2. Induction phase
3. Secondary loss of response.

The main hypothesis of this work is that tailoring treatment to the individual by way of TDM will result in improvement in clinical outcomes, biochemical parameters, and most importantly, long lasting sustained mucosal healing and deep remission.

# **CHAPTER 2-GENERAL MATERIALS & METHODS**

## **2.1 Study design**

### **2.1.1 General Overview**

This dissertation involved a number of different studies focused on the impact of loss of response, as well as the role for therapeutic drug monitoring in optimising response rates to anti-TNF $\alpha$  therapy. The individual cohorts will be described, at the start of individual chapters. This chapter will describe indications for the use of anti-TNF $\alpha$  therapy, as well as some of the key clinical, biochemical, endoscopic scoring systems used, to evaluate and assess response. In addition, the methods for the key laboratory techniques used for therapeutic drug monitoring will be described.

Ethical approval for this study was approved from Tallaght Hospital / St. James's Hospital Joint Research Ethics Committee (REC), and informed consent was obtained from patients for enrolment in the study.

### **2.1.2 Indications for infliximab**

Patients treated with infliximab, as part of this project, either commenced treatment at the study outset, or were already established on standard maintenance therapy. As mentioned in the opening chapter, infliximab is licensed for the use in moderate to severely active UC or CD. It may also be used in patients intolerant of immunomodulators, as well as for the treatment of penetrating complications for CD. It is administered as a standard intravenous infusion of 5mg/kg, at week 0, 2, 6 and then every 8 weeks thereafter. Some of the patients on maintenance therapy may have doses



previously intensified by either increasing the dose administered to 10mg/kg, or having the infusion interval shortened to 4 or 6 weekly infusions.

### **2.1.3 Indications for adalimumab**

Similarly for adalimumab, patients were either commenced treatment at the study outset, or were already established on standard maintenance therapy. Adalimumab is also licensed for the use in moderate to severely active UC or CD. It may also be used in patients intolerant of immunomodulators, as well as for the treatment of penetrating complications for CD. It is administered as a subcutaneous injection, at a dose of 160mg week 0, 80m week 2, and 40mg every other week thereafter. Some of the patients on maintenance therapy may have doses previously intensified by having the injection interval shortened to every week.

## **2.2 Disease Activity Scoring**

### **2.2.1 General Overview**

When assessing disease activity in IBD, a number of different clinical, endoscopic and biochemical markers may be utilised. There is no uniform consensus amongst the IBD research community, but this project used a number of widely recognised activity markers. Endoscopic assessment took place in the Department of Gastroenterology, Tallaght Hospital. As per standard practice informed, written consent was obtained from patients, and risks associated with colonoscopy were explained carefully. Scoring systems for endoscopic activity were calculated by the endoscopist at time of colonoscopy where possible, otherwise they were retrospectively calculated.

## 2.2.2 Montreal Classification

The Montreal Classification also accurately subtypes different IBD phenotypes, allowing accurate comparison between clinical trials [130]. It takes into account age of onset, of disease, disease location, and disease behaviour. Different scoring systems are used for both CD and UC (Tables 2.1 & 2.2).

**Table 2.1: Montreal Classification for Crohn’s disease**

Montreal Classification Crohn’s disease	
Age at Diagnosis	A1: less than 16 years A2: between 17-40 years A3: over 40 years
Location	L1: ileal L2: colonic L3: ileo-colonic L4: isolated upper digestive
Behaviour	B1: non stricturing, non-penetrating B2: stricturing B3: penetrating P: perianal disease

**Table 2.2: Montreal Classification for extent of ulcerative colitis**

Montreal Classification extent UC		
E1	Ulcerative proctitis	Involvement limited to the rectum
E2	Left sided UC (distal)	Involvement limited to distal to splenic flexure
E3	Extensive UC (pancolitis)	Involvement extends beyond splenic flexure

### 2.2.3 Harvey- Bradshaw Index for Crohn's Disease

Harvey Bradshaw Index (HBI) was devised in 1980 as a simpler method of assessing clinical activity than the Crohn's Disease Activity Index (CDAI) [131]. It consists of only clinical parameters:

- general well-being (0 = very well, 1 = slightly below average, 2 = poor, 3 = very poor, 4 = terrible)
- abdominal pain (0 = none, 1 = mild, 2 = moderate, 3 = severe)
- number of liquid stools per day
- abdominal mass (0 = none, 1 = dubious, 2 = definite, 3 = tender)
- complications, as above, with one point for each

One point each is added for each set of complications:

- the presence of joint pains (arthralgia) or frank arthritis
- inflammation of the iris or uveitis
- presence of erythema nodosum, pyoderma gangrenosum, or aphthous ulcers
- anal fissures, fistulae or abscesses
- other fistulae
- fever during the previous week.

Clinical response is usually defined as a HBI  $\leq 3$  or  $< 30\%$  reduction in these scores from baseline. A score of less than 5 is generally considered to represent clinical remission.

## **2.2.4 Partial Mayo score for Ulcerative Colitis**

Partial Mayo score is a non invasive measure of clinical activity in UC. It has been shown to perform as well as the invasive Mayo score in identifying patient perceived clinical response [132]. It is composed of three categories:

- Stool frequency (based on previous 3 days) (0 = no stools, 1 = 1-2 stools more than normal 2 = 3-4 stools more than normal 3 greater than 5 stools more than normal)
- Rectal bleeding (0 = no blood seen, 1 = streaks of blood with stool, less than half the time, 2 = obvious blood with stool most of the time, 3 = blood alone passes)
- Physician's Global Assessment (0 = normal, 1=mild disease, 2= moderate disease, 3= severe disease)

The physician's Global Assessment acknowledges the sub scores, the daily record of abdominal discomfort and functional assessment and other observations such as physical findings and patient's performance status. Clinical response is defined as a partial Mayo score  $\leq 4$  or a  $<30\%$  reduction in these scores from baseline.

## **2.2.5 Simple Endoscopic activity Score for Crohn's Disease (SES-CD)**

SES-CD was developed in 2004 by a European multicenter prospective study as an attempt to simplify a previously used score Crohn's Disease Endoscopic Index of Severity (CDEIS) [133]. It is based on the importance and reproducibility of the most relevant endoscopic characteristics of CD. Selected endoscopic parameters (presence and size of ulcers, proportion of surface covered by ulcers, proportion of surface

affected by disease, and presence and severity of stenosis) are scored from 0 to 3. It is also assessed in the five ileocolonic segments. The sum of the scores for each variable ranging from 0 to 15, except for the presence and extent of stenosis, which ranges from 0 to 11, yields a total SES-CD score of 0–56. More specifically, ileocolonoscopy findings are scored according to SES-CD as following: The four endoscopic variables are scored from 0 to 3 in each bowel segment (ileum, right/transverse/left colon, and rectum): presence and size of ulcers (none = score 0; diameter 0.1–0.5 cm = score 1; 0.5–2 cm = score 2; >2 cm = score 3); extent of ulcerated surface (none = 0; <10% =1; 10%–30% =2; >30% =3); extent of affected surface (none = 0; <50% =1; 50–75% =2; >75% =3); and presence and type of narrowing's (none = 0; single, can be passed = 1; multiple, can be passed = 2; cannot be passed = 3).

As with CDEIS, higher SES-CD scores indicate more severe disease. Classifications used are as follows [134]:

- 0–2: inactive
- 3–6; mild
- 7–15 moderate
- severe >16
- 

### **2.2.6 Mayo Endoscopic Sub-score for Ulcerative Colitis**

The Mayo endoscopy sub score (MES) (four-point scale) was developed in 1987 by Schroeder et al [135]. Partly due to its simplicity, the MES is the most commonly used endoscopic activity index in clinical trials for evaluating treatment efficacy in terms of endoscopic improvement. A score of 0 or 1 correlates with inactive disease, with a score of 3 representing severe disease.

## **2.3 Biochemical Markers of Inflammation & Disease Activity**

### **2.3.1 General Overview**

Biochemical markers, offer a non-invasive means of assessing for disease related inflammation and activity. They have been shown to correlate with both clinical, as well as endoscopic activity. For example in UC patients, CRP elevation is significantly associated with severe clinical and endoscopic activity but not with histological inflammation [136]. This project will utilise both serum CRP and albumin.

### **2.3.2 Laboratory analysis of C-reactive protein and serum albumin**

CRP and serum albumin were measured by standard measure in the Department of Chemical Pathology, Tallaght Hospital. Normal CRP was defined as <5 mg/L and normal serum albumin was >35g/L.

## **2.4 ELISA methods for measuring anti-TNF $\alpha$ trough & antibody levels**

### **2.4.1 General overview**

As mentioned in the opening chapter, ELISA is the standard technique, for measuring patient individual anti-TNF $\alpha$  trough and antibody levels, as part of therapeutic drug monitoring. The ELISA laboratory analysis was performed in the main research laboratory, Trinity Centre for Health Sciences, Tallaght Hospital, Dublin 24.

## **2.4.2 Specimen Collection & Handling**

Serum samples were collected from enrolled patients in the Department of Gastroenterology, Tallaght Hospital, within 24-48 hours of the next adalimumab subcutaneous injection or infliximab intra-venous infusion. Once samples were collected, a serum separator tube was used to collect serum. Samples were allowed to clot for 30 minutes, then centrifuged at 15 minutes at 1000 x g. Serum was removed, and samples stored at <-20°C.

## **2.4.3 Preparation of Reagents**

- **TNF-alpha (Peprotech # 300-01a; 50 µg)**

Prior to opening, the vial was centrifuged. 500 µl sterile water was added for a final concentration of 0.1 mg/ml (100 µg/ml). The reconstituted vial was allowed to sit at room temperature for 2 hours, before use. The solution was then stored in working aliquots at -80°C. The working dilution in phosphate buffered saline (PBS) was 75 µl TNFa in 10ml PBS for 750ng/ml for drug detection, and the working dilution in PBS was 50 µl TNF in 10ml PBS for 500 ng/ml for anti-drug antibody detection.

- **Wash Buffer.**

Consisted of PBS, 0.05% Tween, and was stored at 4°C for up to 1 month.

- **Block Buffer.**

Consisted of 1% bovine serum albumin (BSA) in PBS. Again stored at 4°C for up to 1 month.

- **Sample Diluent**

Consisted of PBS, 0.05% Tween and 0.1% BSA.

- **Horseradish peroxidase (HRP)-labelled goat antihuman IgG (Fc fragment)**  
**(MP biomedical # 67417)**

Prior to opening, the vial was centrifuged. 2ml of distilled water was added for a concentration of 0.7 mg/ml. Solution was aliquoted and stored at -80°C. The solution was diluted to a working concentration of 0.62 µg/ml in reagent diluent, 7 µl in 8 ml, and 9 µl in 10ml.

- **HRP-labelled goat anti-human (Fab')<sub>2</sub> fragment antibody (MP biomedical # 55224)**

Again vial was centrifuged before opening. 2mls of distilled water was added for a concentration of 5.9mg/ml. Stored in working aliquots at -80°C. Solution was diluted 1:100 in PBS for a 59 µg/ml stock. 10 µl of stock was added to 1000 µl reagent diluents for 600ng/ml standard. A 1:2 fold serial dilutions in reagent diluents was made.

- **HRP-labelled goat anti-human λ chain (serotec STAR129p)**
- **Adalimumab (Humira 50mg/ml stock)**

Adalimumab was diluted 1:1000 in PBS for a 50,000 ng/ml stock (10µl in 10ml). 8 ul was added to 1ml for 400 ng/ml standard and 2 fold serial dilutions were made.

- **Infliximab (Remicade 100mg powder)**

2mls sterile water added for a 50ng/ml stock. Solution diluted 1:1000 in PBS for a 50,000 ng/ml stock (10µl in 10 ml). Again 8 µl was added to 1ml for 400ng/ml standard and 2 fold serial dilutions were made.

- **Substrate solution (Fischer 10076433)**



1:1 mixture of Color Reagent A (H<sub>2</sub>O<sub>2</sub>) and Color Reagent B Tetramethylbenzidine (TMB) was made. Solution was then mixed 1:1 fresh (within 15 minutes of use).

- **Stop solution (Sigma 35276-1L)**

Sulfuric acid solution 2N H<sub>2</sub>SO<sub>4</sub>

#### **2.4.4 Dilution of reagents**

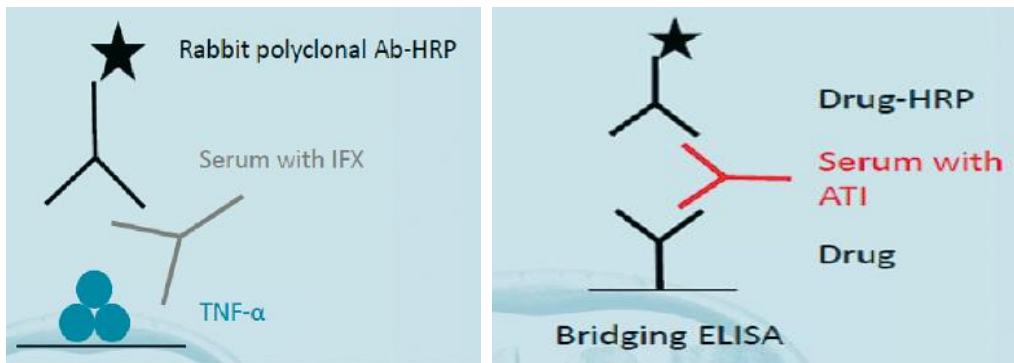
All reagents were brought before room temperature before use. All components were allowed to sit for a minimum of 15 minutes with gentle agitation after initial reconstitution. Working dilutions were prepared and used immediately. TNF was diluted in PBS. Detection antibody was diluted in sample diluents.

#### **2.4.5 Plate Coating & Blocking-Detection of Trough Levels**

Drug levels were assayed using a protocol adapted from Ungar B et al, using a sandwich ELISA technique to detect anti-TNF $\alpha$  and antibody levels (**Figure 2.1**) [70]. A 96 –well ELISA microplate (Thermo Scientific NUNC, Basingstoke, UK) (**Figure 2.2**) was coated with 500 ng/ml recombinant human TNF $\alpha$  (Peprotech, London, UK) overnight at room temperature. The next day, each well was aspirated and washed with Wash Buffer, repeating the process 2 times, for a total of 3 washes. Each well was washed by filling each well, with Wash Buffer (400 $\mu$ l) using a squirt bottle. Attention was made to ensure complete removal of liquid at each step. After the last wash any remaining wash Buffer was removed by inverting the plate and blotting it against clean

paper. Plates were blocked by adding 200µl Block Buffer to each well. Plates were incubated at room temperature for one hour.

**Figure 2.1: ELISA 'sandwich technique' for measuring anti-TNFα trough and antibody levels (Roblin et al)**



**Figure 2.2: ELISA microplate:**



## 2.4.6 Assay Procedure-Detection of Trough Levels

Serum samples were diluted 1:100 with Sample Diluent. Drug standards were prepared in Sample Diluent at the following concentrations: 400ng/ml, 200ng/ml, 100ng/ml, 50ng/ml, 25ng/ml, 12.5ng/ml 6.25ng/ml and 0 ng/ml. 100µl of sample or standard was added per well in duplicate. The plates were covered with an adhesive

strip and left to incubate for 90 minutes at room temperature. Further aspiration and washing was performed, as above. After washing, horse radish peroxidase (HRP)-conjugated goat anti-human IgG Fc fragment antibody (MP Biomedicals, Illkirch Cedex, France) was added at a concentration of 0.62 µg/ml in Reagent Diluent. 100µl of diluted antibody was added to each well. Again an adhesive strip was used to cover the plates, and incubate them for 60 minutes. Aspiration/washing steps were repeated.

100 µl of Substrate Solution tetramethylbenzidine (TMB) substrate (Thermo Scientific) was added to each well. Plates were left to incubate at room temperature for 20 minutes. Following addition of the stop solution (2N H<sub>2</sub>SO<sub>4</sub>) absorbance was read at 450 nm on an EL-800 plate reader (Biotek, Bad Friedrichshall, Germany) (**Figure 2.3**).

**Figure 2.3: EL-800 plate reader:**



#### **2.4.7 Calculation of Results-Detection of Anti-TNF $\alpha$ Trough Levels**

The duplicate readings for each standard, control and sample were averaged, and the average zero standard optical density (OD) was subtracted. Drug concentrations in

serum samples were determined using a standard curve generated from absorbance readings of infliximab or adalimumab added at concentrations from 0 to 400 ng/ml. The drug concentration cut-off level was calculated using the average concentration obtained from unexposed controls plus 3 standard deviations [105].

## **2.4.8 Plate Coating & Blocking-Detection of Antibody Levels**

Anti-drug antibody levels were assayed using a protocol adapted from Ungar B et al [70]. ELISA plates (Thermo Scientific NUNC) were coated overnight with 500 ng/ml TNF $\alpha$  (Peprotech), as outlined above. Blocking and washing was performed, as for detection of trough levels.

## **2.4.9 Assay Procedure-Detection of Antibody Levels**

100  $\mu$ l of drug (0.1 mg/ml infliximab or adalimumab) was added to the plates for 90 minutes, followed by 100 $\mu$ l of diluted serum (1:10 dilution) for 90 minutes. After washing, goat anti-human  $\lambda$  chain HRP-conjugated antibody (AbD Serotec, Oxford, UK) was added at a dilution of  $2.5 \times 10^4$  for 60 minutes, subsequently reacted with TMB substrate and the reaction stopped using 2N H<sub>2</sub>SO<sub>4</sub>.

## **2.4.10 Calculation of Results-Detection of Anti-TNF $\alpha$ Antibody Levels**

Absorbance at 450 nm was determined on an EL-800 plate reader. Anti-drug antibody concentrations were determined by calibration to a standard curve generated using HRP-labelled goat anti-human IgG F (ab')<sub>2</sub> fragment antibody (MP

Biomedicals) at concentrations from 0 ng/ml to 600 ng/ml. The anti-drug antibody concentration cut-off was calculated using the average concentration obtained from unexposed controls plus 3 standard deviations [105].

# **CHAPTER 3- Clinical and biochemical predictors of loss of response to anti-TNF $\alpha$ therapies in patients with inflammatory bowel disease.**

## **3.1 Introduction**

As mentioned previously TNF $\alpha$  is one of the main drivers of the inflammatory cascade involved in IBD [42]. It is involved in cell differentiation and signalling, and aids cytokine gene expression. These processes all assist the progression of inflammation throughout the gastrointestinal tract. Anti-TNF $\alpha$  therapies have been used to induce and maintain remission in patients with both Crohn's disease, and ulcerative colitis [137-138]. Their use has resulted in improved patients outcomes, helped reduce hospitalisation rates and surgical intervention, as well as leading to an increased likelihood of mucosal healing. Response rates to anti-TNF $\alpha$  therapy are variable, but undoubtedly they have helped improve clinical and endoscopic response rates.

Loss of response to anti-TNF $\alpha$  therapy is still a concern. There are still large subsets of patients who don't respond very well to induction anti-TNF $\alpha$  therapy, experiencing a primary LOR. It is defined as failing to achieve improvement in clinical symptoms and signs, despite an adequate course of induction therapy. Studies have shown that primary LOR may affect up to 13-40% of patients [139].

In addition there is also a significant cohort of patients who do well initially with anti-TNF $\alpha$  therapy, but overtime gradually experience a secondary loss of response. Secondary LOR may be defined as a recurrence of disease activity, during the

maintenance phase of therapy, despite an initial response at the end of induction therapy. In a systematic review in CD patients by Gisbert et al, the risk of loss of infliximab response and need for infliximab dose intensification on an annual basis was consistently set at around 13% per patient-year [140]. Similarly for UC, there is ample evidence from the literature for a need to dose intensify in-order to regain clinical response [141-142].

Anti-TNF $\alpha$  therapy is costly, and has a number of side effects and associated toxicities. Furthermore the burden of IBD is huge on both patients and healthcare systems. Therefore any strategies that help predict future response to anti-TNF $\alpha$  therapy is to be welcomed. This would allow better, more cost effective use of anti-TNF $\alpha$  therapy, and ensure patients care is optimised in the best possible way. Overcoming LOR is an important goal of IBD therapy, and would lead to improved outcomes, less hospitalisation rates, reduced need for surgical intervention, as well as increased rates of mucosal healing, which may help alter the natural history of the disease, and make real tangible differences for patients suffering with IBD. Accurately identifying patients at risk of lack of response to anti-TNF $\alpha$  therapy is of clinical benefit and will help in their overall management. This would facilitate adjustments to patient's treatment, such as dose escalation, addition of immunomodulators for optimal combination therapy, or the utilisation of therapeutic drug monitoring to adjust doses, based on anti-TNF $\alpha$  trough and antibody levels, as mentioned previously in the TAXIT study [68].

Before considering predictors of loss of response, it's worth mentioning factors that are associated with positive outcomes and improved response rates. Recognised predictors of response to anti-TNF $\alpha$  therapy include colonic disease, shorter disease duration, mild-to –moderate disease, non-smoking, as well as underlying genetic factors, and possible individual clearance rates of anti-TNF $\alpha$  drugs [143].

## 3.2 Aims

1. To assess response rates to anti-TNF $\alpha$  therapy in a tertiary referral centre
2. To identify any clinical and biochemical predictors associated with loss of response.

## 3.3 Materials & Methods

A retrospective, observational study was designed at our centre. Inclusion criteria were all patients older than 17 years old with IBD who started treatment with anti-TNF $\alpha$  drugs, either infliximab or adalimumab, between January 2013 to January 2015. Patients were followed up for an additional year. Patients were commenced on anti-TNF $\alpha$  therapy due to moderate to severe Crohn's disease or ulcerative colitis, not responding to conventional corticosteroid or immunosuppressive treatment or as a result of intolerance or hypersensitivity to such therapies.

Standard induction doses were used for both infliximab and adalimumab. In addition during the maintenance phase of therapy doses were intensified, as per standard practice, if patients were felt to be experiencing a secondary LOR. This would involve clinical review, assessment of endoscopic and biochemical markers where appropriate or where available.

Clinical response was defined as improvement in clinical symptoms, based on either HBI for CD or partial Mayo scores for UC. Treatment failure was defined as the need for dose intensification because of LOR, surgery, or therapy discontinuation for ineffectiveness/LOR. Clinical assessments were recorded. Doses were adjusted as required per standard protocols. For infliximab either by doubling dose to 10mg/kg



from 5mg/kg, or shortening frequency of administration to either 4 or 6 weekly, from standard 8 weekly infusions. For ADL dosing frequency was shortened to every week, from every other week, as required. Patient data and demographics were obtained from patients electronic patient records. CRP and albumin levels were retrospectively reviewed. Samples were recorded at the start of anti-TNF $\alpha$  therapy and at week 14, the end of induction therapy.

Data was compared between patients who maintained remission, with those who had a secondary LOR. Results are shown as Odds ratio (OR) and 95% C.I. and analysed using the Chi-square test and multivariable logistic regression analysis. Statistical analysis was performed using MedCalc Statistical Software version 17.4 (MedCalc Software bvba, Ostend, Belgium; <http://www.medcalc.org>; 2017).

## **3.4 Results**

### **3.4.1 Baseline Characteristics**

During the observational period, 99 patients were commenced on adalimumab therapy, and 61 on infliximab therapy. In terms of patient characteristics, for the cohort mean age was 40.5 years, female gender 89 (55.6%), positive smoking status at anti-TNF $\alpha$  induction 24/99 (15%). For adalimumab 80 (80.8%) had CD, while 43 (70.5%) of patients treated with infliximab had CD. Mean duration of disease, was 8.09 years, for ADL, 11.43 years for IFX. 34.4% (21/61) of patients treated with IFX had prior anti-TNF $\alpha$  exposure, compared to 4.0% (4/99) for ADL ( $p < 0.0001$  95% CI 0.20 to 0.42). In terms of combination therapy, rates were similar, 45.9% (28/61) of infliximab patients were treated with either azathioprine/6-MP versus 34.3% (34/99) for

adalimumab ( $p = 0.1468$  95% CI -0.04 to 0.27) (**Table 3.1**). Average duration of adalimumab therapy was 1.36 years, 1.6 years for infliximab.

**Table 3.1: Baseline Patient Characteristics of predictors of LOR cohort**

	<i>Infliximab</i>	<i>Adalimumab</i>	<i>Total</i>	<i>P value</i>	<i>OR (95% CI)</i>
Number	61 (38.1%)	99 (61.9%)	160		
Mean Age	40.86	40	40.3	0.68	
Gender (female)	36 (59%)	58 (58.6%)	94 (58.8%)	0.47	
CD	43 (70.5%)	80 (80.1%)	123 (76.9%)	<b>0.07</b>	<b>0.56 (0.27-1.19)</b>
Disease Duration (yrs)	9.43	9.42	9.62	0.65	
Age at onset					
A1	12 (27.9%)	12 (15%)	24 (19.5%)	<b>0.0055</b>	<b>2.19 (0.89-5.42)</b>
A2	24 (55.8%)	51 (63.8%)	75 (61%)	0.19	
A3	7 (16.3%)	17 (21.2%)	24 (19.5%)	0.25	
Behaviour					
B1	17 (39.5%)	27 (33.8%)	44 (35.7%)	0.19	<b>2.79 (1.2-6.2)</b> <b>3.03 (1.20-7.68)</b>
B2	9 (20.9%)	37 (46.2%)	46 (37.4%)	0.26	
B3	18 (41.9%)	16 (20%)	34 (42.5%)	<b>0.008</b>	
Perianal	13 (30.2%)	10 (12.5%)	23 (18.7%)	<b>0.015</b>	
UC Severity					
E1	0	0	0		

	<i>Infliximab</i>	<i>Adalimumab</i>	<i>Total</i>	<i>P value</i>	<i>OR (95% CI)</i>
E2	9 (50%)	7 (36.7%)	16 (43.2%)	0.13	
E3	9 (50%)	12 (63.3%)	21 (56.8%)	0.32	
Smoking	7 (11.5%)	16 (16.2%)	23 (14.4%)	0.20	
Combination therapy	28 (45.9%)	34 (34.3%)	62 (38.8%)	0.078	1.62 (0.84-3.11)
Prior anti-TNFa use	21 (34.4%)	4 (4.0%)	25 (15.6%)	<b>0.001</b> <b>(0.2-0.41)</b>	<b>12.48</b> <b>(4.0-38.6)</b>
Previous surgery	7 (11.5%)	28 (28.3%)	35 (21.9%)	<b>0.003</b>	<b>0.33</b> <b>(0.13-0.81)</b>

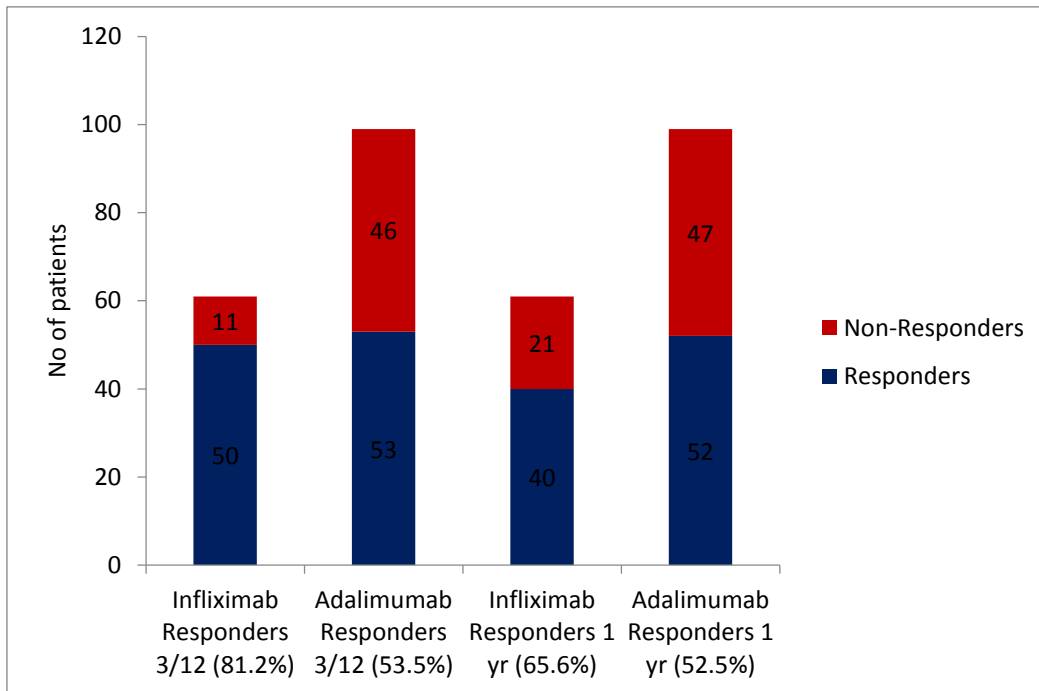
### 3.4.2 Clinical response at end of induction and one year follow-up: Infliximab versus Adalimumab

In terms of clinical response at the end of induction therapy, there was a trend in favour of infliximab, with 81.2% (50/61) of patients treated with infliximab responding compared to 53.5% (53/99) for adalimumab ( $p < 0.001$  95% CI 0.17 to 0.46 O.R. 4.9) (**Figure 3.1**).

Overall response rate for the cohort one year after commencing anti-TNFa therapy was 57.5%, giving a LOR rate of 42.5%. Response rates were greater overall for patients treated with infliximab versus adalimumab (40/61 65.6% v 52/99 52.5%,  $p$  value =0.05) at the end of one year (**Figure 3.1**). There were no statistical differences in response rates, in terms of patient characteristics, disease behaviour, location or disease duration. There was a trend towards increased LOR for patients with ileo-colonic

disease, 26/37 (70.3%) of adalimumab patients with loss of response, had ileo-colonic disease, compared to 26/43 (60.5%) of adalimumab patients who responded at the end of induction therapy, p value = 0.18.

**Figure 3.1: Response rates for infliximab and adalimumab at end of induction and at one year follow up.**



### 3.4.3 Predictors of Loss of Response

Pooling the response rates for both infliximab and adalimumab identified a number of key factors and predictors associated with loss of response (**Table 3.2**). One can see that those patients who were treated with adalimumab were more likely to experience a primary LOR. 80% of the overall anti-TNFa non-responders were treated with adalimumab.

**Table 3.2: Predictors of primary response/non response for patients treated with Infliximab/Adalimumab (pooled data)**

<i>Predictor</i>	<i>Anti-TNF<math>\alpha</math> Responders</i>	<i>Anti-TNF<math>\alpha</math> Non-Responders</i>	<i>P value</i>	<i>O.R. (95% C.I.)</i>
Number	102 (63.8%)	58 (36.2%)		
Mean Age	41.4	38.4	0.207	
Gender (female)	53(52%)	34 (58.6%)	0.21	
<b>Infliximab</b>	<b>50 (49%)</b>	<b>11 (19%)</b>	<b>0.001</b>	<b>4.11 (1.9-8.8)</b>
<b>Adalimumab</b>	<b>52 (51%)</b>	<b>47 (80%)</b>	<b>0.001</b>	<b>0.24 (0.1-0.52)</b>
CD	79 (77.5%)	44(75.9%)	0.41	
Disease Duration (years)	9.43	9.42	0.90	
<b>Smoking</b>	<b>10 (9.8%)</b>	<b>12 (20.7%)</b>	<b>0.05</b>	<b>0.42 (0.17-1.05)</b>
<b>Combination therapy</b>	<b>45 (44.1%)</b>	<b>17 (29.3%)</b>	<b>0.03</b>	<b>1.9 (0.95-3.79)</b>
<b>Prior anti-TNF<math>\alpha</math> use</b>	<b>13 (12.7%)</b>	<b>12 (20.7%)</b>	<b>0.028</b>	<b>0.59 (0.23-1.32)</b>
Previous surgery	14 (13.7%)	14 (24.1%)	0.11	
<b>Week 14 CRP &lt;5 mg/L</b>	<b>90 (88.2%)</b>	<b>28 (48.3%)</b>	<b>0.0001</b>	<b>8.04 (3.64-17.75)</b>

Patient age, gender, disease phenotype, disease location and severity had no impact on response rates between responders and non-responders. However this study did identify some key predictors of LOR. Smoking was significantly associated with LOR.

12/58 (20.7%) of anti-TNFa non-responders smoked versus 10/102 (9.5%) of responders (p value = 0.05 95% C.I. -0.0 to 0.22 O.R. 2.4).

### **3.4.4 Impact of combination therapy and prior anti-TNFa use on Loss of Response**

In addition this cohort study illustrated the clear benefit of combination therapy of anti-TNFa with immunomodulators, in overcoming LOR. 45/102 (44.1%) of anti-TNFa responders, received combination therapy versus 17/58 (29.3%) for non-responders (p value = 0.03 95% C.I. 0.35 to 0.62 O.R. 1.9).

As discussed previously prior anti-TNFa therapy is associated with increased rates of LOR, and our study hints at this. For the pooled data 12/58 (20.7%) of anti-TNFa non responders, were previously exposed to another anti-TNFa agent, versus 13/102 (12.7%) for responders (p value = 0.10 95% C.I. -0.02 to 0.04 O.R. 0.42). (**Table 3.2**).

### **3.4.5 Relationship between Week 14 CRP and Loss of Response**

CRP at week 14 was also an important biochemical predictor of loss of response, based on our study results. Reinisch et al have previously demonstrated that a week 14 CRP <5 mg/L is associated with sustained clinical remission [138]. For the pooled data 90/102 (88.2%) of anti-TNFa responders, had a week 14 CRP <5 mg/L, versus 28/58 (48.3%) for non-responders (p value = 0.001 95% C.I. 0.27 to 0.53 O.R. 8.04). Linked in with this, mean CRP levels at week 14 were considerably higher in patients who didn't respond to anti-TNFa than those who did. Non-responders mean week 14 CRP was 19.1 mg/L versus 4.2 mg/L for responders (p value = 0.027). In addition serum

albumin was also informative, with responders having on average higher mean week 14 albumin levels, than non-responders, 43.8 g/L versus 41.5 g/L ( p value = 0.01).

### 3.4.6 Sub-analysis of infliximab and adalimumab loss of response

As mentioned above, there was a significant difference in response rates between infliximab and adalimumab, so it's important to sub-analyse for the individual agents, to help more accurately identify predictors of LOR (Tables 3.3 & 3.4).

**Table 3.3: Predictors of primary response/non-response for infliximab patients**

<i>Predictor</i>	<i>Infliximab Responders</i>	<i>Infliximab Non-Responders</i>	<i>P value</i>	<i>O.R. (95% C.I.)</i>
Number	50 (81.2%)	11(17.8%)		
Mean Age	38.6	41.36	0.5458	
Gender (female)	23(46%)	7 (63.6%)	0.31	
CD	36(72%)	7(63.6%)	0.31	
Disease Duration (years)	10.91	13.8	0.24	
Peri-anal fistulating disease	13 (26%)	3 (27.3%)	0.47	
Smoking	5 (10%)	2 (18.2%)	0.27	
Combination therapy	24 (48%)	4 (36.4%)	0.25	
<b>Prior anti-TNFa use</b>	<b>13 (26%)</b>	<b>8 (72.7%)</b>	<b>0.015</b>	<b>0.1318 (0.03-0.6)</b>
<b>Week 14 CRP &lt;5 mg/L</b>	<b>42 (84%)</b>	<b>3 (27.3%)</b>	<b>0.0001</b>	<b>14 (3.04-64.48)</b>
<b>Mean week 14 CRP (mg/L)</b>	<b>4.98</b>	<b>27.6</b>	<b>0.0013</b>	
Mean albumin week 14 (g/L)	43.3	41.2	0.14	

**Table 3.4: Predictors of primary response/non response for patients treated with Adalimumab**

<i>Predictor</i>	<i>Adalimumab Responders</i>	<i>Adalimumab Non-Responders</i>	<i>P value</i>	<i>OR (95% CI)</i>
Number	53 (53.5%)	46(46.5%)		
Mean Age	41.4	38.4	0.207	
Gender (female)	30(56.6%)	27 (58.7%)	0.42	
CD	43(81.1%)	37(80.4%)	0.47	
Disease Duration (years)	8.0	8.2	0.90	
Peri-anal fistulating disease	4 (7.5%)	6 (13%)	0.37	
<b>Smoking</b>	<b>5 (9.4%)</b>	<b>10 (21.7%)</b>	<b>0.02</b>	0.38 (0.12-1.22)
<b>Combination therapy</b>	<b>21 (39.6%)</b>	<b>13 (28.2%)</b>	<b>0.001</b>	<b>8.06 (2.71-23.95)</b>
<b>Prior anti-TNFa use</b>	<b>0 (0%)</b>	<b>4 (8.7%)</b>	<b>0.015</b>	<b>0.84 (0.01-44.30)</b>
Previous surgery	14 (26.4%)	14 (30.4%)	0.50	
<b>Wk 14 CRP &lt;5 mg/L</b>	<b>48 (90.6%)</b>	<b>25 (54.3%)</b>	<b>0.0001</b>	<b>8.06 (2.72-23.95)</b>
<b>Mean week 14 CRP (mg/L)</b>	<b>3.3</b>	<b>16.9</b>	<b>0.027</b>	
<b>Mean albumin week 14 (g/L)</b>	<b>44.1</b>	<b>41.6</b>	<b>0.01</b>	

Prior anti-TNFa exposure, was a risk factor for lack of response, 8/11 (72.7%) of infliximab non-responders v 13/50 (26%) for responders, (p= 0.004 95% CI -0.77 to -0.17 OR 0.13). Similarly for adalimumab 4/37 (10.8%) of non-responders had prior anti-TNFa exposure versus 0/43 (0%) for responders, (p value = 0.0219 95% CI -0.20 to -0.0 OR 0.84)



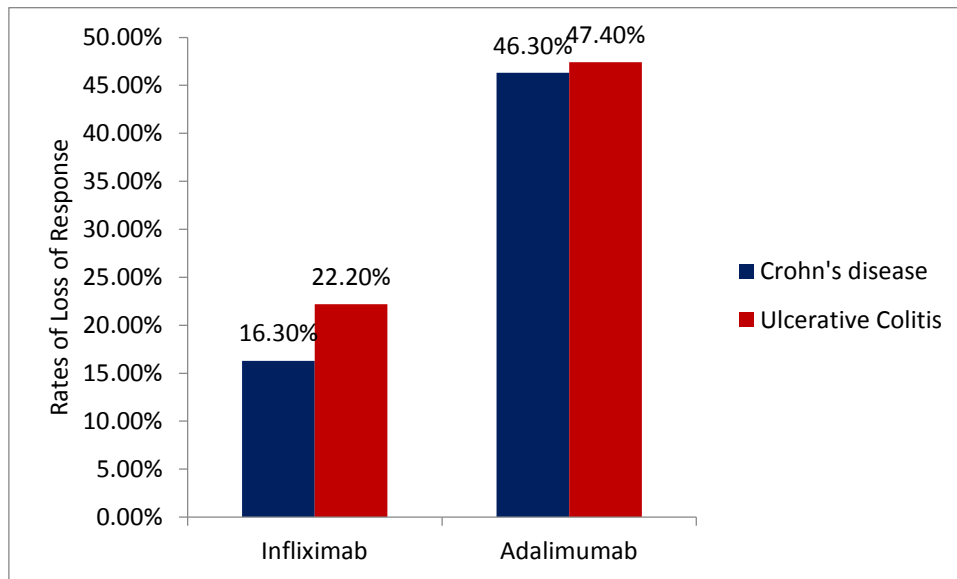
In terms of dose escalation, for the duration of the study, slightly more patients treated with adalimumab had their doses escalated compared to infliximab, 31.3% (31/99) versus 22.3% (14/61) (p =0.207 95% CI -0.05 to 0.24).

For the cohort, there was a strong association between smoking and primary LOR at the end of induction therapy, for both anti-TNF $\alpha$  agents. 5/53 (9.4%) of adalimumab patients who responded smoked, versus 10/46 (21.7%) of adalimumab non-responders, (p value = 0.02 95% C.I. -0.2 to -0.02 O.R. 0.38). Interestingly for patients treated with adalimumab, all of the smokers, had underlying Crohn's disease. Similarly for infliximab there was a trend towards higher smoking rates in patients who failed infliximab, at the end of induction therapy. There was a smoking rate of 2/11 (18.2%) in non-responders versus 5/53(10%) in responders (p value = 0.27).

There was a suggestion, that patients with peri-anal fistulating Crohn's disease, were more likely to be experience LOR to adalimumab, 4/53 (7.5%) of adalimumab responders had perianal disease, compared to 6/46 (13%), for adalimumab non-responders, though not statistically significant, p value = 0.37. There was no difference for infliximab.

There was no difference in rates of LOR to adalimumab between CD and UC patients. LOR to adalimumab was 37/80 (46.3%) for CD, compared to 9/19 (47.4%) for UC (p value = 0.46) (**Figure 3.2**). Likewise for infliximab, there was no statistical difference in LOR rates, between CD and UC. LOR rate for CD was 7/43 (16.3%) versus 4/18 (22.2%) for UC (p value = 0.30)

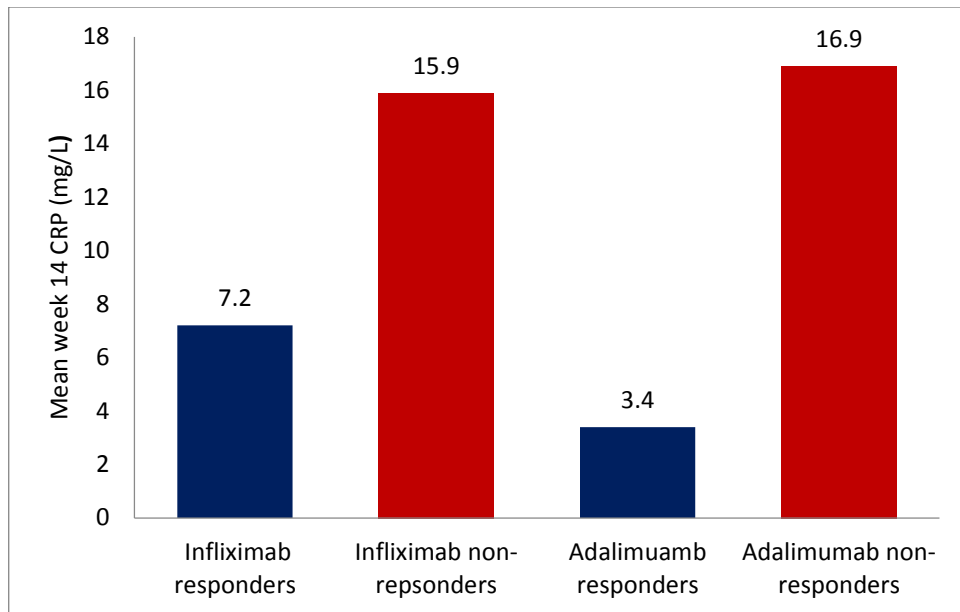
**Figure 3.2: Comparison of rates of loss of response between infliximab and adalimumab, by phenotype**



### 3.4.7 Week 14 CRP as a predictor clinical response

In addition a week 14 CRP of less than 5 mg/L was a good predictor of clinical response. For adalimumab non-responders, 25 (54.3%) had CRP <5 mg/L, versus 48 (90.6%), for responders (p value = 0.0001 95% CI 0.2-0.52 OR 8.06). There was also a significant association with infliximab, 42/50 (84%) of infliximab responders, had week 14 CRP < 5 mg/L, compared to 3/11 (27.3%) for non-responders (p value = 0.0001 95% CI 0.31-0.83 OR 14). Further analysis, confirmed the role of CRP as a predictor clinical response. For infliximab non-responders mean CRP was 15.9 mg/L, compared to 7.2 mg/L for infliximab responders. Similarly for adalimumab non-responders, average CRP was 16.9 mg/L, compared to 3.4 mg/L for responders (**Figure 3.3**). The delta change in CRP was also noteworthy, varying from -82.8% for adalimumab responders, to +12.6% for non-responders. For infliximab, the delta change was -64.7% for responders, compared to -42.4% for non-responders.

**Figure 3.3: Mean week 14 CRP based on anti-TNF $\alpha$  response rates.**



### **3.4.8 Serum albumin as a predictor clinical response**

Serum albumin was a useful predictor of loss of response for albumin. Mean serum albumin in adalimumab responders was 44.1 g/L, compared to 41.6 for non-responders (p value = 0.01). There was no statistical differences for infliximab, mean serum albumin in infliximab responders was 43.3 g/L, compared to 41.2, for non-responders, (p value =0.14). (Tables 3.3 & 3.4)

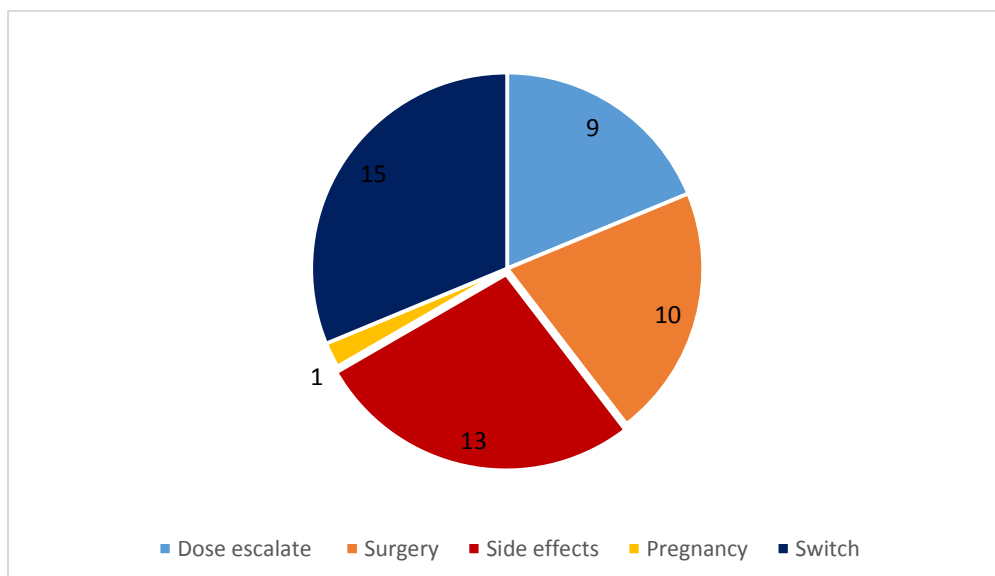
### **3.4.9 Overall Outcomes**

In terms of patients who did experience a primary LOR at end of induction therapy, 10/46 (21.7%) of adalimumab non-responders ultimately required surgery over the duration of the study and follow-up period (Figure 3.4). 9/46 (20%) of patients had their adalimumab doses escalated to 40mg weekly, and 3/9 (33%) subsequently

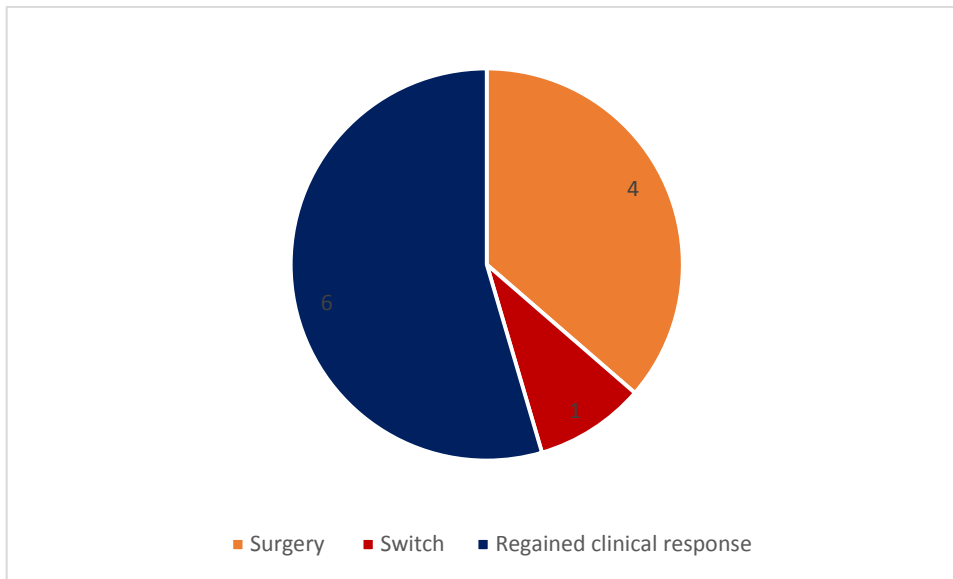
regained response. Of the patients who failed to respond at end of induction therapy, 13/46 (28.3%) experienced side effects, necessitating discontinuation of the drug, without consideration of dose escalation. This included one case of tuberculosis, despite a normal baseline CXR, and TB Quantiferon test. Of the patients who responded at the completion of induction therapy, 33/53 (66.3%) remained well on adalimumab. 9/53 (20%) required a dose escalation, and subsequently improved. 1 patient required surgery, and 9/53 (20%) had to stop due to side effects.

For infliximab non-responders at end of induction therapy, doses were escalated in all patients, however by the end of 1 year follow-up, 4/11 (36.4%) required surgery, 1/11 (9.1%) switched to ustekinumab, and 6/11 (54.5%) regained clinical response (Figure 3.5).

**Figure 3.4: Outcomes of adalimumab non-responders, post induction (one year follow-up)**



**Figure 3.5: 1 year outcomes of infliximab non-responders, post induction (one year follow-up)**



Of the original responders to adalimumab at the end of induction therapy, 33/53 (62.2%) remained well. 18.8% required dose escalation in their adalimumab, and all patients regained clinical response. 8 patients, had their adalimumab discontinued due to side effects. Likewise for infliximab response was maintained, over one year follow-up. 37/50 (74%) were well on standard dosing. 9/50 (18%) required dose escalation, with a subsequent regain in response. 2/50 (4%) had to stop due to anaphylaxis and 2/50(4%) required surgery, for secondary LOR.

### **3.5 Discussion**

Anti-TNF $\alpha$  therapy has greatly improved outcomes for patients with IBD. However LOR, both primary and secondary has significant implications for patients with IBD, leading to increased hospitalisation rates, greater steroid usage, more complications, and increased rates of surgical intervention. Therefore identifying clinical and biochemical predictors of LOR, clearly offers a number of advantages, allowing clinicians to better identify patients, who are more likely to respond to anti-

TNF $\alpha$  therapy. This will facilitate more cost effective and beneficial use of the anti-TNF $\alpha$  therapy.

This study confirms that primary LOR remains a significant problem, with rates of 46.5% primary LOR, for adalimumab, and 18.8% for infliximab for our cohort. Possible explanations for this include the more rapid onset of action of infliximab, compared to adalimumab, due to its intravenous mode of administration. A 2014 meta-analysis confirmed this disparity [145]. However this view hasn't been fully endorsed. Disease location has been thought to have a role to play, in response rates in patients with Crohn's disease. Our study showed a trend towards reduced response rates, in Crohn's, patients with ileo-colonic disease, compared to those with colonic disease. 70.3% of adalimumab patients with loss of response, had ileocolonic disease, compared to 60.5% of adalimumab patients who responded at the end of induction therapy, p value = 0.18. Some previous studies, have shown, that for patients with Crohn's disease, isolated Crohn's colitis, may respond better to anti-TNF $\alpha$  therapy, compared to patients with small bowel disease [146].

Smoking has been shown previously, to have significant adverse effects on outcomes, and response rates to anti-TNF $\alpha$  therapy, leading to higher societal costs, and reduced quality of life [147]. For this cohort, 20.7% of anti-TNF $\alpha$  non-responders, smoked, compared, to 9.5% of responders. Interestingly for our study, all of the adalimumab non-responders who were smokers had underlying Crohn's disease. It's thought that nicotine, and other toxic chemicals, lead to impaired healing of the ulcerated inflamed intestinal tract, therefore reducing the likelihood of clinical response and mucosal healing, leading to increased surgical rates [148]. This study and others emphasise the need for patients with Crohn's disease to stop smoking, to help overcome suboptimal response rates to anti-TNF $\alpha$  therapy.

Biochemical predictors of LOR are very useful in the management of patients treated with anti-TNF $\alpha$  therapy. They offer a quick and cheap means of gauging response. CRP as mentioned previously has been shown to be a predictive factor, and marker of inflammation in IBD [149]. Furthermore a week 14 CRP of less than 5 mg/L has been shown, to accurately predict clinical response at the end of induction therapy [150]. For this group of patients, 88.2% of responders had a CRP <5 mg/L, compared to 48.3% of non-responders. In addition, mean CRP rates at week 14, are also informative. Non-responders mean week 14 CRP was 19.1 mg/L versus 4.2 mg/L for responders. This study confirms the important role the CRP has to play, as a biochemical target when using anti-TNF $\alpha$  therapy or as a predictor of LOR. Our study also showed that low albumin levels, are associated with an increased likelihood of primary LOR. A recent study confirms that for infliximab, CRP of less than <5 mg/L and a serum albumin of greater than 35g/L is associated with sustained clinical response [151]. Other biomarkers that have a role to play in predicting response to treatment include faecal markers like, faecal calprotectin. It has a role as a biomarker for inflammation in the gut, as well as predicting response to treatment and the risk of subsequent relapse [152]. Faecal calprotectin was not routinely measured in this cohort at the time of study.

There is ample evidence that combination therapy, with the use of immunomodulators, leads to improved response rates, and can help overcome LOR [22]. For this cohort, there was strong evidence of this with 44.5% of anti-TNF $\alpha$  responders, being on combination therapy, versus 29.3% for non-responders (p value = 0.03). It is thought that the addition, of an immunomodulator, leads to reduced anti-TNF $\alpha$  antibody formation, and improved anti-TNF $\alpha$  trough levels. This leads in to the

potential of therapeutic drug monitoring to identify an immune basis, behind LOR, and allows strategies to be developed to help overcome it [108].

Prior anti-TNFa exposure has been known to be associated with worse outcomes [153]. For this cohort, 72.7% of infliximab non-responders had prior anti-TNFa exposure compared to 26% for responders. Similarly the results here were comparable for adalimumab, with 10.8% of adalimumab non-responders having prior anti-TNFa exposure versus 0% for responders. This and other data, can guide clinicians as well as patients expectations when starting anti-TNFa therapies, in patients who have previously failed or been intolerant to other anti-TNFa agents.

As mentioned above, LOR has a significant impact on patients overall outcomes. 21.7% of our adalimumab non-responders, required surgical intervention. Dose escalation to 40mg every week, at the end of induction therapy can help non-responders, achieve clinical response. 20% of non-responders, had their dose escalated, and 33% subsequently achieved clinical response. A meta-analysis from 2011 has indicated that dose escalation, in primary adalimumab non-responders, can help achieve clinical response, and subsequently helped to maintain remission [154]. Our results would support this approach.

Drug intolerance and toxicity, can have a significant impact, on the use of anti-TNFa therapy. For our cohort, 28.3% of adalimumab non-responders, at the end of induction therapy, developed side effects that prevented dose escalation and necessitated discontinuation of their therapy. Toxicity to anti-TNFa together with primary and secondary loss of response can therefore limit its effectiveness. As a result, it's essential to develop strategies, to overcome LOR and improve response rates and help achieve mucosal healing



## 3.6 Conclusions

In conclusion, anti-TNF $\alpha$  therapy has significantly improved patient outcomes; however loss of response is still a big concern, with almost 40% experiencing LOR in our cohort over a one year period. Clinical (smoking, ileal CD, prior anti-TNF $\alpha$  exposure and protective benefits of combination therapy) and biochemical (elevated CRP and low serum albumin at week 14) predictors of loss of response are useful, for predicting response to anti-TNF $\alpha$  therapy as well as counselling and advising patient expectations.

# **CHAPTER 4- One year follow up of an IBD cohort who previously have had anti-TNFa trough and antibody levels assessed.**

## **4.1 Introduction**

Tissue Necrosis Factor-alpha (Anti-TNFa) therapies have revolutionised the management of inflammatory bowel disease (IBD). Their earlier introduction, and use in combination with immunomodulators has resulted in a significant improvement in response and remission rates in both ulcerative colitis and Crohn's disease [48, 155]. In addition they help to induce long lasting mucosal healing and deep remission, and may help alter the natural history of the disease, and reduce the risk of future complications. However overtime response to anti-TNFa therapy can be lost, resulting in clinical relapse and disease progression. As mentioned earlier, results from ACCENT 1 showed that 80% of patients treated with infliximab in CD respond initially, but overtime 30% of patients will lose response, requiring dose and/or interval adjustments [58]. This is similar to our data, which showed a LOR rate of 42.5% at one year follow-up post commencement of anti-TNFa therapy. Loss of response (LOR) is associated with flares of disease, increased hospitalisation rates, need for surgical interventions, and decline in quality of life.

Response may be lost for a multitude of reasons. Immunogenicity may account for some of this loss of response. Immunogenicity, as discussed in the opening chapter, is the formation of antibodies against anti-TNFa therapies. This can be associated with reduced drug trough levels, and a loss of clinical efficacy [156]. Immunogenicity is

associated with increased drug clearance, which directly leads to reduced trough levels. This can ultimately lead to loss of response, infusion reactions and the need for dose intensification, or the need to switch to an alternative agent. Ternant et al's two-compartment pharmacokinetic model for infliximab has shown that the clearance increases 2.7-fold in patients positive for antibodies to infliximab (ATI'S) as compared with patients without ATI'S [67]. Therapeutic drug monitoring may have a role in predicting subsequent treatment failure. A recent study by Liefferinckx et al has shown that infliximab trough levels, at induction, help predict treatment failure during maintenance therapy. In a longitudinal cohort study of 269 IBD patients, they found at week 6, median IFX trough levels in patients requiring a switch to another treatment due to LOR (LOR switched group) (2.32  $\mu\text{g/ml}$  [0.12-19.93  $\mu\text{g/ml}$ ]) was lower than in patients with long-term response (long-term responders) (8.66  $\mu\text{g/ml}$  [0.12-12.09  $\mu\text{g/ml}$ ],  $P = 0.007$ ) and in patients responding to optimization (LOR optimized group) (7.28  $\mu\text{g/ml}$  [0.17-14.91  $\mu\text{g/ml}$ ],  $P = 0.021$ ) [157].

Antibody formation is also associated with a reduction in adalimumab trough levels, and increased risk of future inflammation and subsequent loss of response, according to post hoc analysis of the Karmiris trial [119]. This and other studies suggest that TDM has an important role to play in evaluating loss of response, as well as developing strategies to overcome this difficult problem.

Ad-hoc calculation of anti-TNF $\alpha$  drug and antibody levels may identify patients who are losing response, and may benefit from drug intensification or alternative therapies. A recent interesting study by Brandse et al, has explored the impact of patient, disease, and treatment characteristics on clearance and immunogenicity of IFX in a real-world patient-with-IBD cohort [158]. They found insufficient exposure below an IFX trough level of 3  $\mu\text{g/ml}$  was the most predictive factor of developing ATI and

resulted in a 4-fold increased risk of ATI development. IFX clearance was affected by body weight (40-149 kg) ranging from 0.27 to 0.53 L/d, serum albumin (2-5.4 g/L) from 0.93 to 0.24 L/d, and titres of ATIs (0-53,000 AU/mL) from 0.36 L/d to 15.93 L/d ( $p < 0.001$ ). Previously biologic-treated patients exhibited a higher clearance of IFX. Furthermore there is expanding evidence from the literature illustrating the association between trough levels and response rates. [92, 95-96].

There is in addition an association between low trough levels, elevated CRP and LOR [94]. Post hoc analysis of the ACCENT 1 trial, also confirmed these important predictors of LOR. Patients with durable sustained response to maintenance infliximab 5 mg/kg had higher post induction trough levels than patients without durable sustained response. Serum infliximab trough levels  $\geq 3.5$   $\mu\text{g/ml}$  and  $\geq 60\%$  CRP decrease were significantly associated with durable sustained response [66]. Thus TDM alongside biochemical markers of disease activity, have a role to play in assessing LOR.

## **4.2 Aims**

1. To explore the relationship between stand-alone/random anti-TNF $\alpha$  trough and antibody levels with one year clinical outcomes.
2. Furthermore to ascertain if TDM, is useful in helping predict future outcomes.
3. In addition, to clarify if there was a link between clinical activity and biochemical markers, with anti-TNF $\alpha$  trough and antibody levels.

## 4.3 Materials & Methods

The cohort consisted of a group of UC and CD patients treated with either infliximab or adalimumab at Tallaght Hospital from January 2014 to January 2015. The cohort had responded initially to standard induction therapy, and were on maintenance therapy. Anti-TNF $\alpha$  trough levels were measured during the maintenance phase of patients' anti-TNF $\alpha$  therapy, in a random fashion. That is, there was no distinction made between those who were responding, and those who were experiencing a secondary loss of response. This cohort was followed retrospectively at one year, to assess clinical outcomes. Missed endpoints were defined as: need for steroids, dose intensification, treatment discontinuation, hospitalisation or surgery. Clinical assessment took place in the form of partial Mayo scores for ulcerative colitis, and Harvey-Bradshaw scores for Crohn's disease. Biochemical parameters of disease activity were measured, including CRP (normal <5 mg/L) and serum albumin (normal >35g/L) levels. Low trough levels for infliximab were defined as <1 $\mu$ g/ml and therapeutic trough levels >3 $\mu$ g/ml Infliximab [85] and low trough levels for adalimumab were defined as <1 $\mu$ g/ml and therapeutic trough levels were defined as >5 $\mu$ g/ml.

Cut-off's for Infliximab and Adalimumab antibodies were defined as 2.5 $\mu$ g/ml and 0.45  $\mu$ g/ml respectively. Trough and antibody status were correlated with outcomes, a p value of < 0.05 was considered significant. Continuous variables were expressed as the median and standard deviation and categorical variables as number and percentage. Mann–Whitney test was used to compare continuous variables and categorical variables were analysed by Fisher's exact test. A two-tailed P < 0.05 was considered statistically significant.

Anti-TNF $\alpha$  trough and antibodies were measured as per ELISA technique described in the Chapter 2, based on technique used by Ungar et al. [70].

## 4.4 Results

### 4.4.1 Baseline Patient Characteristics

Baseline patient characteristics for our cohort are shown in **Table 4.1**. Total number of patients in our cohort were 74, 37 (50%) were female, mean age 41 years. In terms of phenotype overall, 61 (82%) had Crohn's disease. 42 (57%) patients received infliximab and 32 (43%) adalimumab. There was no statistical difference in prior surgical resection rates between the two groups, 5/42 (11.9%) of infliximab patients had prior intestinal resection, versus 7/34 (21.9%) for the adalimumab group. A statistically significant larger number of patients treated with infliximab were on combination therapy with azathioprine. 22 (52%) of patients treated with infliximab were on combination therapy versus only 1 (3%) for adalimumab (p value <0.001, 95% C.I. 0.31 to 0.68 O.R. 0.03). The mean HBI for the cohort was 3.85 for infliximab, 2.88 for adalimumab, and mean partial Mayo score, was 0.75 for infliximab, and 0.40 for adalimumab.

Patients treated with adalimumab had a slightly increased CRP at baseline compared to infliximab 6.5 mg/L versus 3.33 mg/L (p value =0.05). Baseline mean HBI's for IFX and ADL were 3.85 and 2.88 respectively. Mean partial Mayo scores for IFX and ADL were 0.75 and 0.40 respectively. Mean serum albumin rates were similar for the two groups (43.3 g/L, for IFX, 42.3 g/L for ADL). In terms of drug dosing 90% (n=38) of IFX were treated with 5mg/kg, 10% (n=4) were on 10mg/kg. Likewise for

ADL, 75% (n=24) were on 40mg every fortnight, with 25% (n=8) on 40mg every week.

**Table 4.1: Patient Baseline Characteristics for patients who had stand-alone anti-TNF $\alpha$  trough and antibody levels measured**

	<i>Infliximab</i>	<i>Adalimumab</i>	<i>Total</i>	<i>P value</i>	<i>OR (95% CI)</i>
Gender					
-Male	22(52%)	15 (47%)	37 (50%)	0.32	
-Female	20 (48%)	17 (53%)	37 (50%)		
Mean Age	38	44	41		
Disease phenotype					
-Crohn's	34 (81%)	27 (84%)	61 (82%)	0.27	
-Ulcerative Colitis	8 (19%)	5 (16%)	13 (18%)	0.35	
Previous surgical resection	5 (11.9%)	7 (21.9%)	12 (16.2%)	0.14	
Anti-TNF $\alpha$					
-Infliximab			42 (57%)		
-Adalimumab			32 (43%)		
Dose (infliximab)					
-5mg/kg	38 (90%)				
-10kg/weekly	4(10%)				
Dose Adalimumab					
-40mg fortnightly		24 (75%)			
-40mg weekly		8 (25%)			
<b>Immunomodulators (azathioprine)</b>					
<b>-yes</b>	<b>22(52%)</b>	<b>1 (3%)</b>	<b>23 (31%)</b>	<b>&lt;0.001</b>	<b>0.03</b>

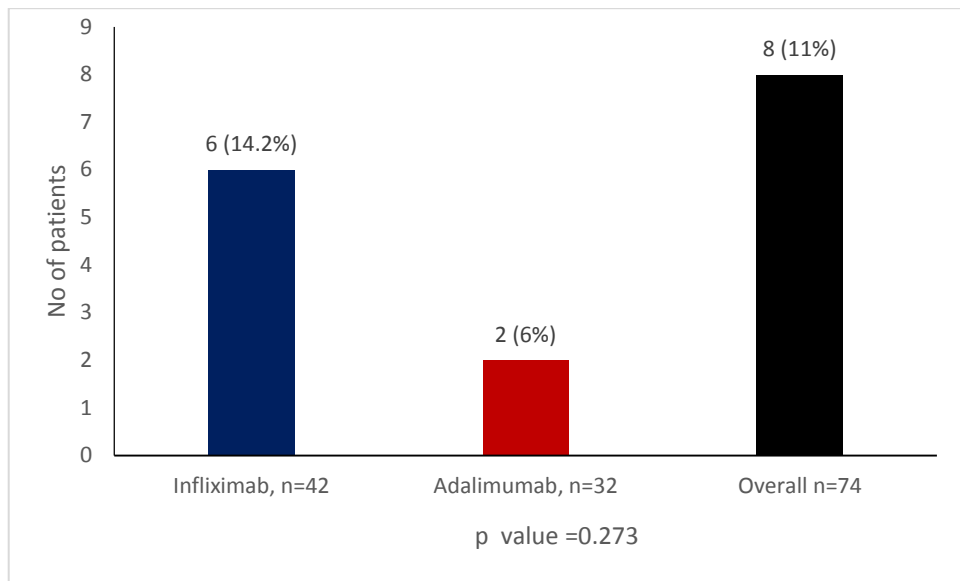
	<i>Infliximab</i>	<i>Adalimumab</i>	<i>Total</i>	<i>P value</i>	<i>OR (95% CI)</i>
<b>-no</b>	<b>20 (48%)</b>	<b>31 (97%)</b>	<b>51 (69%)</b>		(0.0037 to 0.235)
Mean CRP (mg/L)	3.33	6.5	4.03	0.05	
Mean albumin (g/L)	43.3	42.3	42.77		
Clinical Assessment					
-Mean HBI	3.85	2.88			
-Mean Partial Mayo	0.75	0.40			
<b>Mean week 14 CRP (mg/L)</b>	<b>3.3</b>	<b>16.9</b>	<b>0.027</b>		
<b>Mean albumin week 14 (g/L)</b>	<b>44.1</b>	<b>41.6</b>	<b>0.01</b>		

#### **4.4.2 Sub-therapeutic anti-TNF $\alpha$ Trough Levels & Antibody Formation**

In terms of trough levels, overall 11% (n=8) had a low trough level (<1  $\mu$ g/ml). 14.2% (6/42) of the cohort treated with IFX had sub-therapeutic trough levels, 6.2% (2/32) of ADL patients had a trough level <1  $\mu$ g/ml (p value = 0.273) (**Figure 4.1**).

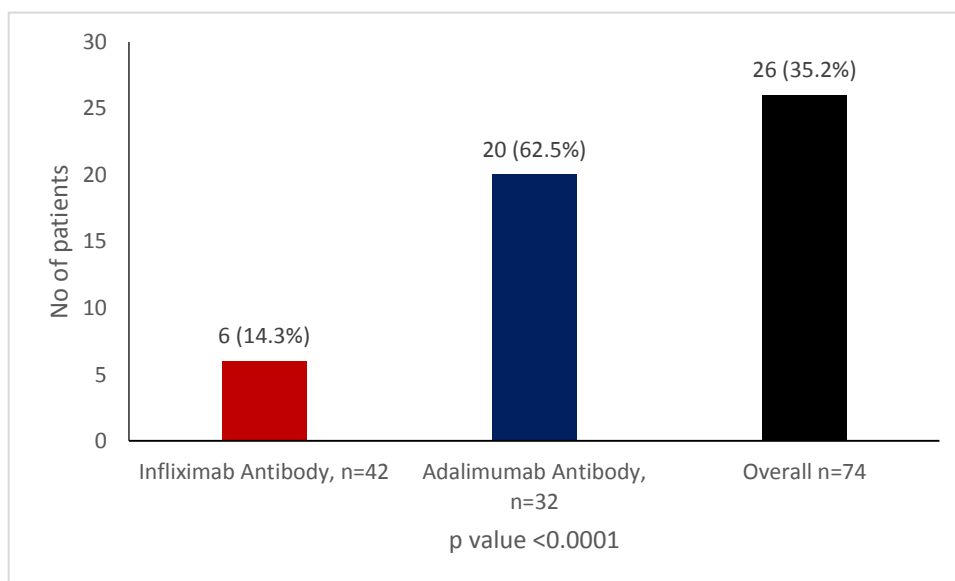


**Figure 4.1: Patients on infliximab/adalimumab with low trough levels < 1µg/ml**



In addition 35.2% (26/74) patients had positive antibodies, 14.3% (6/42) for IFX and 62.5% (20/32) for ADL (p value <0.0001, 95% C.I. -0.68 to -0.29) (**Figure 4.2**). However only 9% of Adalimumab antibodies were strongly positive.

**Figure 4.2: Rates of antibody formation against infliximab/adalimumab**



### 4.4.3 Mean anti-TNF $\alpha$ trough levels

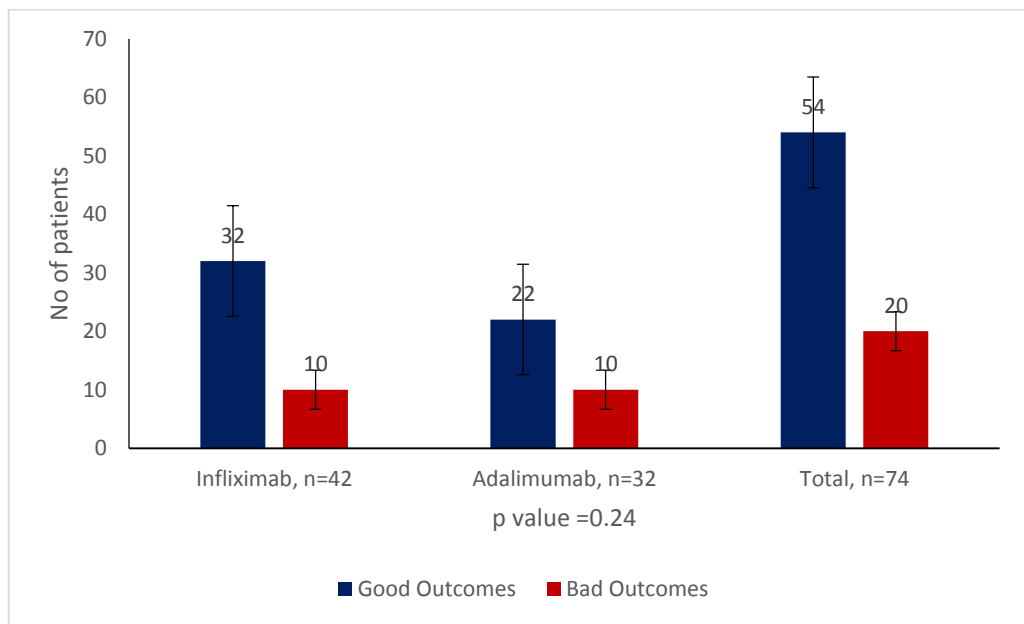
For the IFX group, overall trough level was 5.4  $\mu\text{g/ml}$ . In total, 13/42 (30%) had clinically active disease while 8/42 (18.6%) had low serum trough levels, mean 0.57  $\mu\text{g/ml}$ . Antibody status and drug trough level did not correlate with CRP however there was a trend towards increased clinical disease activity with low drug trough level (12.5% inactive disease vs 36% with active disease) but this did not reach statistical significance ( $p < 0.08$ ). In addition a low trough level was not associated with biochemical activity (CRP 2.8 mg/L vs. 3.3 mg/L). While 4 (50%) had clinically active disease in the low trough versus 9 (26%) in the normal trough group. This difference did not reach statistical significance, ( $p = 0.08$ , OR 3.3) Mean ADL trough levels were 4.9  $\mu\text{g/ml}$  and 2/32 (6%) had sub-therapeutic trough levels. There was no relationship between ADL trough and antibody status with CRP levels.

### 4.4.4 One Year Outcomes

In terms of one year outcomes, 27% ( $n = 20$ ) overall had a missed endpoint, with a similar proportion in each group 24% ( $n = 10$ ) Infliximab and 31% ( $n = 10$ ) adalimumab ( $p$  value = 0.24) (**Figure 4.3**). Sub classifying missed endpoints, 20% ( $n = 2$ ) of infliximab patients required surgery, 30% ( $n = 3$ ) required a dose escalation, 20% ( $n = 2$ ) had to stop due to side effects/toxicity (65 year old male with recurrent pneumonia, and 23 year old male due to immune mediated peripheral neuropathy), 10% ( $n = 1$ ) required rescue steroids, and 20% ( $n = 2$ ) had to switch to alternative agent due to LOR. Sub classifying for adalimumab 30% ( $n = 3$ ) of patients required surgery, 20% ( $n = 2$ ) required a dose escalation, 20% ( $n = 2$ ) had to stop due to side effects/toxicity (65 year old female with recurrent sinusitis, and 35 year old female with psoriasis), 20% ( $n = 2$ ) required steroids, and 10% ( $n = 1$ ) had to switch to an alternative agent. For Crohn's patients

22.2% (18/81) had a poor response, versus 15.4% (2/13) for ulcerative colitis (p value = 0.278).

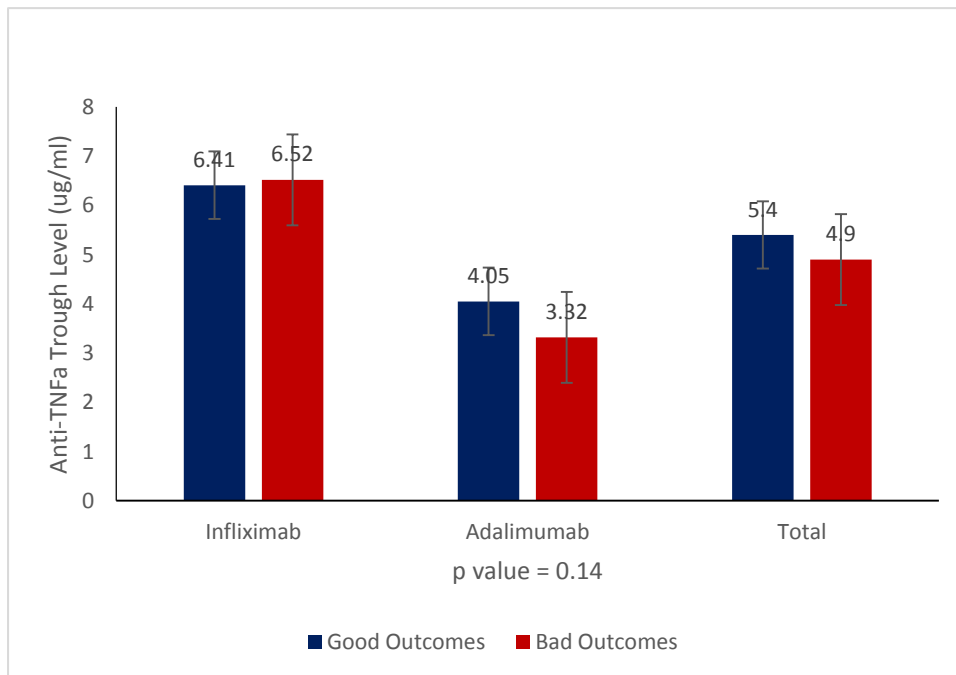
**Figure 4.3: One year clinical outcomes for patients on maintenance infliximab/adalimumab**



#### 4.4.5 Mean anti-TNF $\alpha$ trough levels, based on clinical outcomes

In Crohn's, overall mean infliximab trough levels were 6.38  $\mu\text{g/ml}$ , versus 6.74  $\mu\text{g/ml}$  for UC, and for adalimumab 3.94  $\mu\text{g/ml}$  versus 2.92  $\mu\text{g/ml}$ . There was no difference in mean trough according to outcome (4.9  $\mu\text{g/ml}$  poor versus 5.4  $\mu\text{g/ml}$  good, p value = 0.14) (**Figure 4.4**). Antibody positivity did not correlate with low trough levels (16.6% versus 83.3%). While 72% (n=31) on Infliximab achieved a recommended trough  $>3 \mu\text{g/ml}$ , none on adalimumab reached a target of  $>5 \mu\text{g/ml}$  (p<0.0001, 95% CI 0.58-0.90). A higher Infliximab trough,  $>3 \mu\text{g/ml}$  was not associated with better outcomes, 3/10 poor versus 8/ 32 good response.

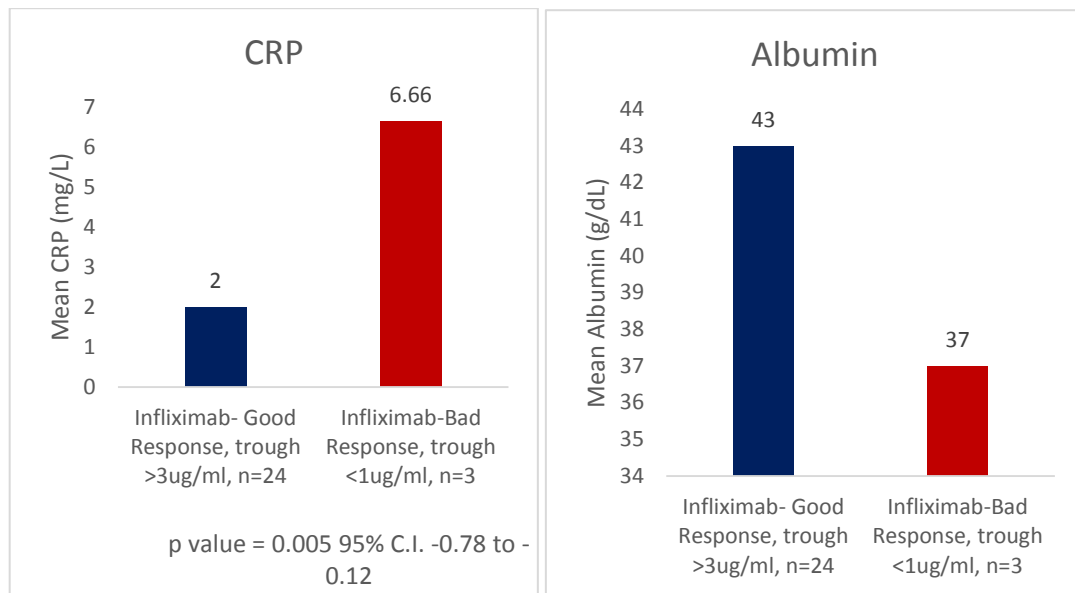
**Figure 4.4: Mean trough levels for infliximab and adalimumab based on outcomes**



#### **4.4.6 Relationship between mean CRP, albumin and clinical outcomes**

Low infliximab trough levels did correlate with high CRP, low albumin and response rates, mean CRP 6.66 mg/L (n=3), mean albumin 37 g/L for patients with low trough levels and poor response versus CRP 2.0 mg/L (n=24), mean albumin 43 g/L for patients with high trough levels and good response (p=0.009, 95% CI -0.78 to -0.12) (**Figure 4.5**). There was no relationship between sub-therapeutic adalimumab trough levels, with clinical or biochemical activity. Mean CRP was 7 mg/L, serum albumin 38g/L, for those with low trough levels, versus a mean CRP of 6.5 mg/L, serum albumin 39g/L, for those with high trough levels (p value =0.3).

**Figure 4.5: Relationship between mean CRP, albumin and infliximab outcomes.**



## 4.5 Discussion

Loss of response is a big concern for anti-TNF $\alpha$  therapies. Immunogenicity, the formation of antibodies against anti-TNF $\alpha$ , leads to increased drug clearance, and reduced trough levels. This process, leads to an increase likelihood of treatment failure, disease relapse and disease progression, as well as increased need for surgical intervention [159].

Therapeutic drug monitoring has been increasingly recognised as a useful tool, to explore an immune basis behind LOR to anti-TNF $\alpha$  therapy. It can be used alongside other biochemical predictors of loss of response such as CRP and faecal calprotectin [66, 160]. This study was a one year, retrospective analysis of a cohort of patients, who previously had stand-alone/random anti-TNF $\alpha$  trough and antibodies measured. This study aimed to see if these stand-alone anti-TNF $\alpha$  trough and antibody levels would be useful in predicting future outcomes.

Similar to other studies, a significant number of this cohort treated with anti-TNF $\alpha$  had a missed endpoint (27% 20/74). LOR leads to increased hospitalisations, need for further steroid usage, and increased surgical intervention. Indeed as mentioned above 22% of patients treated with infliximab required surgery, as well as a similar number for adalimumab 27%. One can therefore see a need to utilise new strategies that help overcome treatment failure, prevent LOR or facilitate a regain in response, leading to an improved likelihood of long lasting deep remission.

As mentioned antibody formation, is a drawback to long-term anti-TNF $\alpha$  use, and may impact on LOR. Our study has shown for our cohort, increased antibody formation against adalimumab compared to infliximab. In addition a larger proportion of infliximab patients were on combination therapy, which is associated with reduced antibody formation. However not all antibodies, are clinically significant, and research is ongoing exploring this link, and deciphering differences between clinically significant and insignificant anti-TNF $\alpha$  antibodies. Possible reasons for the difference in adalimumab response rates, and trough rates in comparison to infliximab for our cohort, may include possible compliance issues, the difference in drug pharmacodynamics, due to its subcutaneous administration. There are also cost implications, with subcutaneous anti-TNF $\alpha$  requires payment by patients themselves, versus hospital financing for intravenous anti-TNF $\alpha$  therapy

For our cohort, stand-alone anti-TNF $\alpha$  trough and antibody levels did not prove useful, in predicting clinical outcomes, based on our 1 year retrospective study. As mentioned above, there was no difference in trough levels, according to response rates. 4.9  $\mu\text{g/ml}$  in patients with poor response versus 5.4  $\mu\text{g/ml}$  in patients with good response rates, p value =0.14). This data suggests that TDM is not helpful, when used in a stand-alone manner, and may be best utilised, at more important time points in a

patients treatment, such as the end of induction, or when evaluating for secondary LOR. In addition again there was no relationship between stand-alone anti-TNF $\alpha$  antibody levels, with response rates. This could suggest that it is the impact of disease activity on anti-TNF $\alpha$  trough and antibody levels, rather than trough levels predicting disease activity.

Other possible explanations for our results were that trough and antibody levels were performed on a broad cohort of patients. All patients were on maintenance phase of their treatment, and relatively well. It maybe that measuring anti-TNF $\alpha$  trough and antibody levels, will prove more informative in the setting of secondary loss of response. Another possibility is that cut-offs used, for high trough levels, <3  $\mu\text{g/ml}$  for IFX or >5  $\mu\text{g/ml}$  for ADL were too high. As mentioned a there is ongoing work into ascertaining the impact of clinically significant versus clinically insignificant antibodies. It's a possibility our antibody assay was detecting a higher degree of clinically insignificant antibodies, hence our high reported rate of anti-TNF $\alpha$  antibody formation, particularly for adalimumab.

This was a retrospective study, analysing one year outcomes in a cohort of IBD patients, who previously had trough and antibody levels measured. The clinicians treating the patients did not have access to the trough and antibody levels during the study duration, and dose adjustment based on this information, was outside the scope of this study.

Our data is similar to other studies, confirming the association between low trough levels, loss of response and elevated CRP [94]. Thus the combination of a patient with low anti-TNF $\alpha$  trough levels, and elevated CRP is a strong predictor of loss of response. It's worth noting, that whilst National Institute for Health and Clinical

Excellence (NICE) guidelines recognise the potential of TDM they currently do not recommend routine adaption in centres where testing is not currently available, citing issues around cost effectiveness and clinical evidence [161]. Furthermore there is evidence that trough levels, may not fully predict outcomes. A study by Gonczi et al has shown that for a group of 291 IBD patients, in UC early biosimilar infliximab trough levels were predictive for short- and medium-term clinical efficacy, whereas in CD, week 2 trough levels were associated only with short-term clinical outcomes [162]. In comparison a normal CRP at week 14, was strongly associated with medium term clinical efficacy. Thus clinicians need to be aware of the role and benefits of TDM, which can be expensive, time consuming, and difficult to interpret, in comparison to the cheaper, more readily available CRP biomarker.

Our study did not confirm an association between trough levels and response rates. Possible explanations include, that the patient population was a heterogeneous group, i.e. was not solely focused on those losing response. In addition, there are ongoing studies exploring the role of clinically significant versus insignificant anti-TNF $\alpha$  antibodies, and their role in LOR.

Our data did show that high CRP/low albumin correlated with low anti-TNF $\alpha$  trough levels and loss of response. Therefore in patients with a high CRP and/or a low albumin, we believe it's worthwhile checking anti-TNF $\alpha$  trough and antibody levels, to aid the decision making process of anti-TNF $\alpha$  dose adjustment or switch in therapy.

Limitations of this study include the retrospective nature of the study design, the sample size, and the ability to correlate results to larger populations, as well as the lack of availability of anti-TNF $\alpha$  trough and antibody levels to clinicians treating patients



during the study period. Never the less, it is a useful retrospective analysis of the drawbacks of using TDM in a stand-alone fashion.

Going forward, it is likely that TDM will have an increasingly important role to play in fine tuning the management of IBD. Stand-alone anti-TNF $\alpha$  trough and antibody levels, are unlikely however to be useful in helping guide the treatment decision making process. Careful thought needs to take place, before governing bodies and societies incorporate TDM into treatment algorithms. As mentioned, the use of TDM at the completion of induction phase of therapy, or during an episode of LOR are likely to prove more beneficial. Another potential role for TDM is in patients at higher risk of LOR, such as those with elevated CRP or low albumin levels. This approach may allow doses of anti-TNF $\alpha$  to be intensified or a switch in therapy arranged, once an immune basis behind LOR has been explored with TDM. This should take place alongside clinical, endoscopic and histological assessment of disease activity. Further work is required to define optimal trough levels.

Finally, overall outcomes were somewhat disappointing, despite adequate median anti-TNF $\alpha$  trough levels, potentially suggesting other non-immune issues could be contributing.

## **4.6 Conclusions**

Loss of response is still a big concern for anti-TNF $\alpha$  therapy. Stand-alone anti-TNF $\alpha$  and antibody levels are not useful predictors of loss of response. The use of TDM needs to be fine-tuned, to best address this important aspect of IBD management.

# **CHAPTER 5- Positive relationship between infliximab and adalimumab trough levels at completion of induction therapy with clinical response**

## **5.1 Introduction**

Anti-TNF $\alpha$  therapies have greatly improved outcomes for patients with IBD. They have longstanding, proven efficacy in both inducing and maintaining remission in IBD [149]. As discussed previously, their use has been associated with reduced need for hospitalisation, improved quality of life, as well as an increased likelihood of mucosal healing, which has been shown to help alter the natural history of the disease. However, for some patients response can be suboptimal, and primary loss of response, at the end of the induction phase of anti-TNF $\alpha$  therapy, can have significant implications for patients, such as further flares of disease, increased steroid requirements, as well as increased need for surgical intervention. Therapeutic drug monitoring at this stage potentially offers the opportunity to proactively tailor therapy and prevent subsequent deterioration and associated complications.

At present no consensus has been reached with regard to a definition of primary nonresponse to anti-TNF $\alpha$  therapy in IBD. It may be recognised as a failure to reach previously described decreases in clinical scores such as partial Mayo, HBI or CDAI following completion of induction therapy [163]. The timeframe for assessing response, to anti-TNF $\alpha$  therapy at the end of induction can vary, but there is a consensus that primary non response to anti-TNF $\alpha$  should not be assessed before 14 weeks for infliximab and 12 weeks for adalimumab [164].

LOR to anti-TNF $\alpha$  therapy as discussed previously is multifactorial. Anti-TNF $\alpha$  itself may be involved, through the impact of anti-TNF $\alpha$  drug pharmacokinetics, pharmacodynamics and immunogenicity. There is evidence that immunogenicity, that is the formation of antibodies against anti-TNF $\alpha$ , can lead to primary LOR in a number of cases. Antibody formation, against anti-TNF $\alpha$  can lead to reduced trough levels of anti-TNF $\alpha$ , which can lead to increase disease activity [165]. Furthermore a study has shown that infliximab trough and antibody levels are reduced in patients, with acute severe compared to moderately severe UC [166]. This is likely due to the inflammatory burden of the disease, and or increased drug clearance.

TDM as mentioned, involves the measurement of an individual's anti-TNF $\alpha$  trough and antibody levels. This can facilitate exploring an immune basis behind an individual's primary LOR. It also offers, the opportunity of adjusting a patients, anti-TNF $\alpha$  dose at the end of induction therapy to help overcome primary LOR. This approach alongside the use of clinical, endoscopic assessment, as well as biomarkers, like CRP and faecal calprotectin, can help improve response rates and outcomes for patients. Roblin et al's study for example, has confirmed that LOR can be predicted, based on a combination, of CRP, infliximab trough levels, as well as stable, infliximab antibodies [66].

Therapeutic anti-TNF $\alpha$  levels may also help predict sustained response for IBD patients. A Czech study has shown that an infliximab trough level, of greater than 3  $\mu\text{g/ml}$ , at the start of maintenance therapy, was associated with sustained clinical response, over a 2 year follow-up period [92]. Similarly for adalimumab, Zittan et al, have shown that higher adalimumab trough levels were significantly associated with MH (median 14.7  $\mu\text{g/mL}$  in those with MH vs 3.4  $\mu\text{g/mL}$  in those without,  $p = 6.25 \times 10^{-5}$ ) [121].

As has been mentioned TDM may help overcome LOR in a number of ways. For example individuals, found to have low trough levels, can have doses increased to increase the possibility of clinical response, or in patients with antibody formation, and low trough levels, immunomodulators, like azathioprine, may be added to reduce antibody formation and improve trough levels. For example, a recent study has shown that for a large number of patients, addition of azathioprine, can help patients treated with adalimumab overcome LOR, by reducing antibody formation, and improving drug trough levels [167].

## **5.2 Aims**

- 1** To explore the relationship between infliximab and adalimumab trough and antibody levels with clinical and biochemical response rates at the end of induction therapy, and at one year follow-up.
- 2** In addition, to identify if therapeutic drug monitoring may be a useful, predictor of primary nonresponse for both infliximab and adalimumab.
- 3** To look at the role of TDM in an Irish cohort.
- 4** Finally to establish if dose intensifying anti-TNF $\alpha$ , based on clinical, endoscopic, biochemical evaluations, and the use of TDM may help regain clinical response at one year follow-up.

## 5.3 Materials & Methods

This was a prospective, single centre study, performed at Tallaght Hospital, Dublin, Ireland. Patients were recruited from the gastroenterology department at Tallaght Hospital, from July 2015 to July 2016. Inclusion criteria were all patients older than 17 years old with IBD who started treatment with anti-TNF $\alpha$  drugs, either infliximab or adalimumab, during the study period for standard indications. Patient demographics, medication and clinical history were collected from the electronic hospital information system. Baseline clinical disease activity indices were performed (Harvey-Bradshaw Index for Crohn's disease and partial Mayo scores for Ulcerative colitis).

Blood was taken just prior to their first maintenance infusion or subcutaneous injection. CRP and serum albumin levels were recorded. Endoscopic assessment, took place prior to study enrolment at the endoscopy department in Tallaght hospital. SES-CD and Mayo endoscopy sub scores were calculated. Only patients who completed standard induction were included for further analysis. Standard induction regimens were used for infliximab 5mg/kg weeks 0, 2 and 6 and for adalimumab, 160mg, 80, mg and 40mg every other week. Patients were reviewed at the end of induction therapy. A decision was made to either to continue anti-TNF $\alpha$  therapy, or consider dose escalation, or switch to alternative agents where appropriate. Patients were reviewed clinically every 3 months, and overall clinical response was reviewed at the end of one year of anti-TNF $\alpha$  therapy. Clinical activity and biochemical markers were recalculated. Repeat endoscopy was performed at the end of one year follow-up.

Clinical response was defined as a HBI of  $\leq 3$  or a partial Mayo score  $\leq 4$  or a reduction in clinical score of  $>30\%$  from baseline. Primary non-response to anti-TNF $\alpha$

therapy was defined as failure to achieve a  $\geq 2$  point decrease in HBI or  $\geq 3$  point decrease in partial Mayo score, or satisfy a physician's global assessment that response had been achieved, following induction therapy.

Anti-TNF $\alpha$  trough and antibodies were measured as described in Chapter 2, based on the ELISA protocol adapted from Ungar et al [70].

Continuous variables were expressed as the median and standard deviation and categorical variables as number and percentage. Mann–Whitney test was used to compare continuous variables and categorical variables were analysed by Fisher's exact test. A two-tailed  $P < 0.05$  was considered statistically significant. A ROC analysis was performed for evaluation of the accuracy of prediction of clinical response by infliximab and adalimumab levels. Statistical analysis was performed using MedCalc Statistical Software version 17.4 (MedCalc Software bvba, Ostend, Belgium; <http://www.medcalc.org>; 2017).

## 5.4 Results

### 5.4.1 Baseline Patient Characteristics

Baseline patient clinical characteristics are shown in **Table 5.1**. In all 35 patients were recruited; 23 with Crohn's disease, and 12 with Ulcerative colitis. 18 patients were treated with adalimumab, 17 with infliximab. The mean age of the cohort was 40.3 years, 22 (62.8%) were female, 12 patients (34.3%) were on concomitant immunomodulators and 9 (25.7%) had prior anti-TNF $\alpha$  exposure. Overall clinical, endoscopic and biochemical activity for the cohort at baseline was, HBI 8.9, partial Mayo 6.8, SES-CD 11, Mayo endoscopy sub-score 2.5, CRP 19.2 mg/L and serum albumin 39 g/L.

There were no significant differences between patients treated with infliximab and adalimumab, in terms of age of onset of disease and disease location. However there was a trend towards more patients treated with adalimumab, having underlying penetrating or perianal fistulating Crohn’s disease. In addition, patients treated with adalimumab, clinically had more active disease at entry, mean HBI 11.5, compared to 7.1 for infliximab (p value =0.03, 95% C.I 0.36 to 7.68). In addition, patients treated with infliximab, were more likely to have been previously treated with prior anti-TNFa, 7/17 (41.7%) of patients, compared to 2/18 (11.1%) for adalimumab (p value = 0.04 95% C.I. 0.01 to 0.59., O.R. 0.19). There was evidence of more significant biochemical activity in patients treated with infliximab, having higher mean CRP compared to adalimumab, mean CRP 24.8 mg/L compared to 13.8 mg/L, for adalimumab (p value = 0.06). Similarly for serum albumin, infliximab patients had a lower mean serum albumin of 36.7g/L compared to 41g/L for adalimumab (p value = 0.02 95% C.I. -8.35 to -0.58).

**Table 5.1: Baseline Patient Characteristics in cohort who had TDM performed at end of induction therapy**

	<i>Infliximab</i>	<i>Adalimumab</i>	<i>Total</i>	<i>P value</i>	<i>OR (95% CI)</i>
Number	17 (48.6%)	18 (51.4%)	35		
Mean Age	38.9	41.8	40.3	0.83	
Gender (female)	10 (58.8%)	12 (66.6%)	22 (62.9%)	0.6	
CD	10 (58.8%)	13 (72.2%)	23 (65.7%)	0.42	
Disease Duration (years)	7.3	9.5	8.6	0.46	
Age at onset					

	<i>Infliximab</i>	<i>Adalimumab</i>	<i>Total</i>	<i>P value</i>	<i>OR (95% CI)</i>
A1	1 (10%)	2 (15.4%)	3 (13%)	0.72	
A2	7 (70%)	7 (53.8%)	14 (60.9%)	0.45	
A3	2 (20%)	4 (30.8%)	6 (26.1%)	0.58	
<b>Disease Location</b>					
L1	2 (20%)	4(30.8%)	6 (26.1%)	0.58	
L2	2(20%)	2 (15.4%)	4 (17.4%)	0.78	
L3	6 (60%)	7 (53.8%)	13 (56.5%)	0.78	
L4	0 (0%)	0 (0%)	0 (0%)		
<b>Disease Behaviour</b>					
B1	4(40%)	5 (33.8%)	9 (39.1%)	0.94	
B2	2(20%)	7 (46.2%)	9 (39.1%)	0.11	
B3	4 (40%)	1 (20%)	5 (21.7%)	0.07	0.37 (0.02-4.71)
Perianal	5 (50%)	1 (12.5%)	6 (26.1%)	<b>0.02</b>	0.11 (0.01-1.24)
<b>UC Severity</b>					
E1	0	0	0		
E2	2 (28.6%)	1 (20%)	3 (25%)	0.76	
E3	5 (71.4%)	4 (80%)	9 (75%)	0.76	
<b>Clinical Scores:</b>					
<b>-HBI</b>	<b>11.5</b>	<b>7.1</b>	<b>8.9</b>	<b>0.03</b>	
-Partial Mayo	7.8	5.6	6.8	0.20	
Severity of inflammation: -SES-CD	9.6	12.2	11	0.39	



	<i>Infliximab</i>	<i>Adalimumab</i>	<i>Total</i>	<i>P value</i>	<i>OR (95% CI)</i>
-Mayo endoscopy score	2.7	2.2	2.5	0.21	
Smoking	2 (11.8%)	0 (0%)	2 (5.7%)	0.14	
Combination therapy	7 (41.2%)	5 (27.7%)	12 (34.3%)	0.42	
<b>Prior anti-TNF<math>\alpha</math> use</b>	<b>7 (41.1%)</b>	<b>2 (11.1%)</b>	<b>9(25.7%)</b>	<b>0.04</b>	<b>0.17 (0.03-1.04)</b>
Previous surgery	4 (57.1%)	2 (11.1%)	6 (17.1%)	0.34	
Mean CRP pre induction (mg/L)	24.8	13.8	19.2	0.06	
<b>Mean serum albumin pre induction (g/L)</b>	<b>36.7</b>	<b>41</b>	<b>39</b>	<b>0.02</b>	

### 5.4.2 Response rates at end of Induction therapy

Overall response rate was for our cohort at end of induction was 51.4% (n=18). The rate of primary LOR was therefore high at 48.6% (**Table 5.2**). There was a statistically greater response rate in patients treated with infliximab, compared to adalimumab, 70.6% (n=12), compared to 33.3 % (n=6) (p value = 0.03 95% C.I. 0.04 to 0.70 O.R. 0.16). In addition, for patients with ulcerative colitis, treated with adalimumab, there was evidence of reduced clinical response, 5/12 (41.7%) had primary non-response. Overall trough levels were 12.5  $\mu\text{g/ml}$  for infliximab (IQR 4.9-19.2), and 4.4  $\mu\text{g/ml}$  (0.2-7.3) for adalimumab (p value 0.005 95% 2.67 to 13.58). The majority, 71.4% had therapeutic trough levels  $>1 \mu\text{g/ml}$ .

**Table 5.2: Outcomes for anti-TNFa responders and non-responders at end of induction therapy**

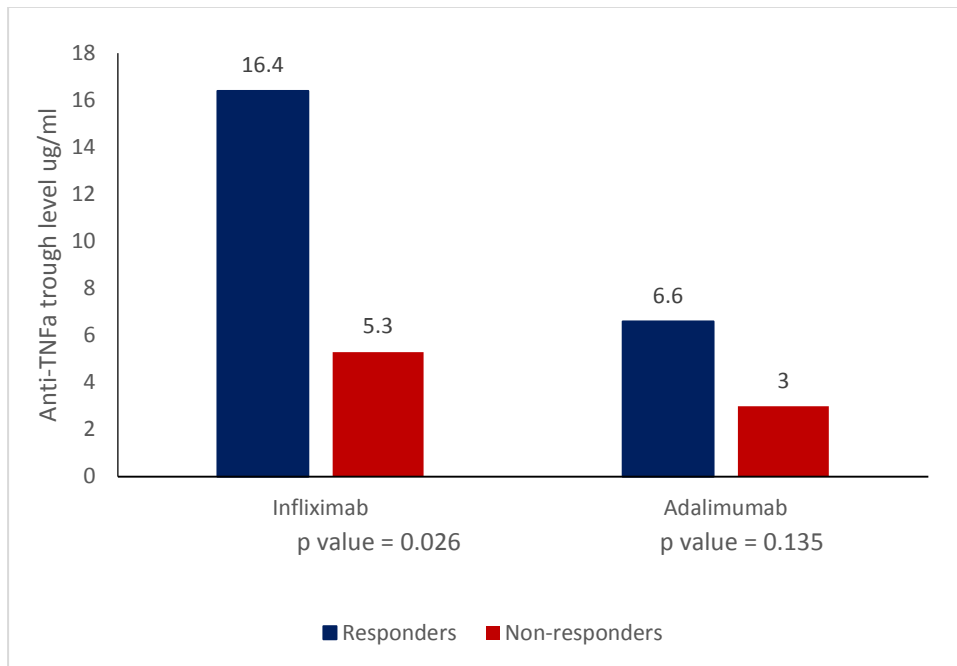
	<i>Responders</i>	<i>Non-responders</i>	<i>Total</i>	<i>P value</i>	<i>OR (95% C.I.)</i>
Cohort	18 (51.4%)	17 (48.6%)	35		
Infliximab (n)	12 (70.6%)	5 (29.4%)	17	<b>0.015</b>	0.16 (0.04-0.70)
-Crohn's	8 (66.7%)	2 (40%)	10	<b>0.005</b>	
-Ulcerative Colitis	4 (33.3%)	3 (60%)	7	0.62	0.33 (0.03-2.87)
Adalimumab (n)	6 (33.3%)	12 (66.7%)	18	<b>0.04</b>	<b>4.8 (1.14-20.1)</b>
-Crohn's	5 (83.3%)	7 (58.3%)	12	0.43	
-Ulcerative Colitis	1 (16.7%)	5 (41.7%)	6	<b>0.017</b>	<b>3.57 (0.3-40.75)</b>
<b>Clinical Scores:</b>					
-Mean HBI Pre Induction	9.7	7.4	8.9	0.25	
-Mean HBI Post induction	3.4	7.6	5	<b>0.004</b>	
-Mean Partial Mayo Pre Induction	6	6.57	6.8	0.79	
-Mean Partial Mayo Post induction	3	6.57	5.8	<b>0.03</b>	
-Mean CRP pre induction (mg/L)	20.5	17.6		<b>0.0083</b>	
-Mean CRP post induction (mg/L)	6.4	12.8		0.39	

	<i>Responders</i>	<i>Non-responders</i>	<i>Total</i>	<i>P value</i>	<i>OR (95% C.I.)</i>
-Mean albumin pre induction (g/L)	39.5	41.8		0.58	
-Mean albumin post induction (g/L)	38.4	41.6		0.90	
CRP <5 mg/L post induction (n)	15	8	23	<b>0.02</b>	
Mean anti-TNF $\alpha$ trough level ( $\mu$ g/ml):					
Infliximab	16.4	5.3	12.5	<b>0.026</b>	
Adalimumab	6.9	3.0	4.4	0.138	
Antibody's level (n)	3 (16.6%)	3 (17.6%)	6 (17.1%)	0.94	

### 5.4.3 Relationship between anti-TNF $\alpha$ trough levels with clinical response at end of induction therapy.

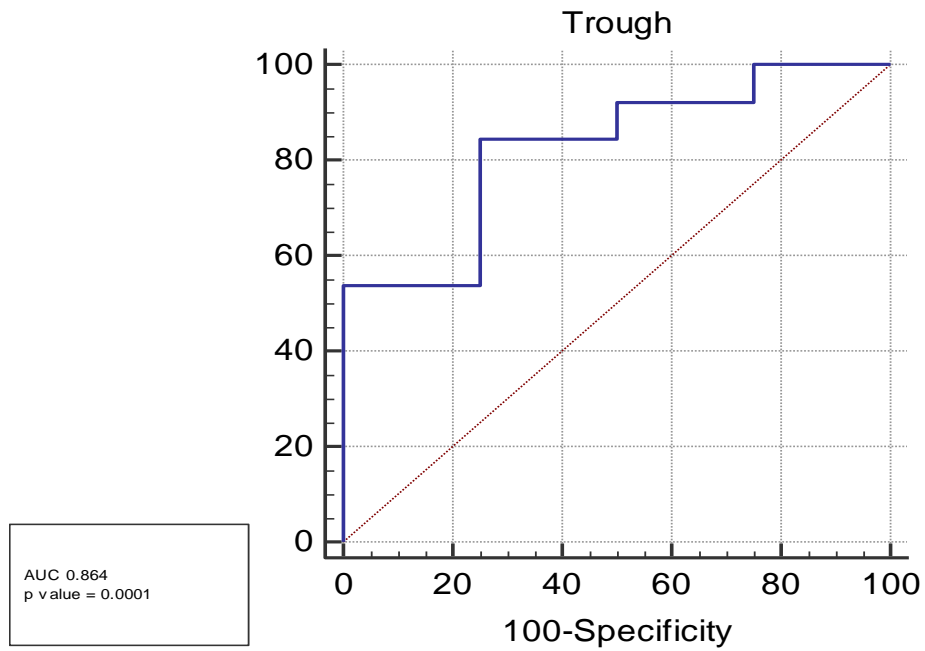
There was a clear link between higher anti-TNF $\alpha$  trough levels at the end of induction with clinical response rates (**Figure 5.1**). For infliximab, mean trough levels in responders were 16.4  $\mu$ g/ml (IQR 8.4-22.7) versus 5.3  $\mu$ g/ml (0.5-8.8) for non-responders (p value = 0.026 95% CI: 1.50-20.7). Similarly there was a link between higher ADL levels and clinical response, though not statistically significant. ADL responders mean trough 6.6  $\mu$ g/ml (IQR 4.9-8.7) versus non-responders 3.0  $\mu$ g/ml (IQR 0.1-2.7) (p value = 0.135 95% CI 1.24-8.43).

**Figure 5.1: Comparison of anti-TNF $\alpha$  trough levels, at end of induction between responders and non-responders**

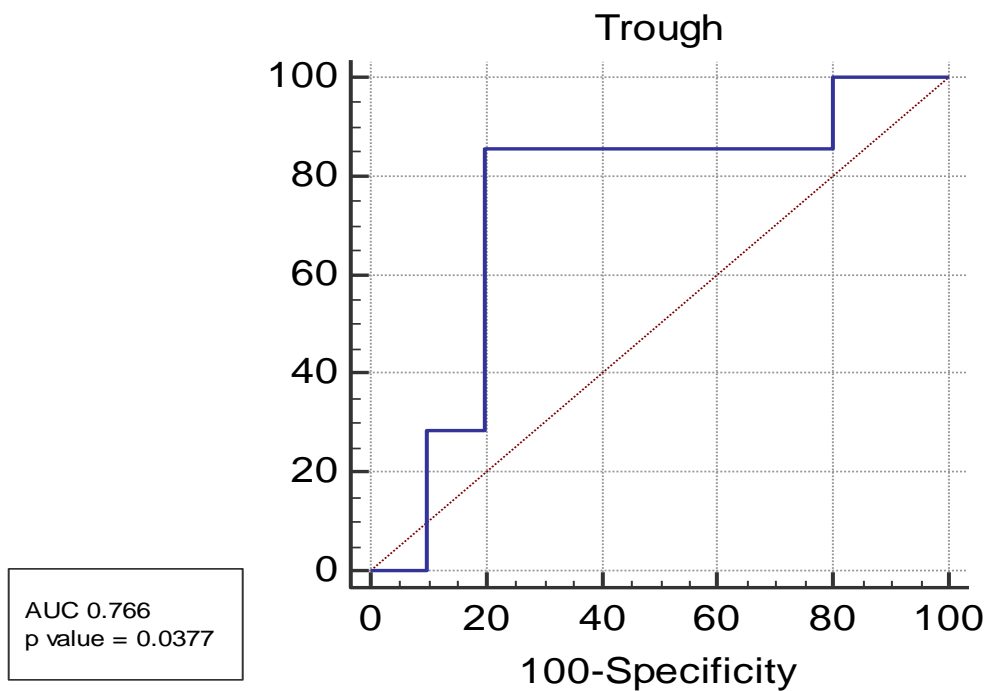


The area under the curve [AUC] for association of IFX level at end of induction with clinical response was 0.864, ( $p = 0.0001$ ). In addition a trough level of  $\geq 4.8 \mu\text{g/ml}$  predicted clinical response at end of induction, with a sensitivity of 90.91% and a specificity of 67% (**Figure 5.2**). Similar the AUC for association of ADL level at end of induction, with clinical response was 0.766, ( $p = 0.0377$ ) (**Figure 5.3**). Furthermore a trough level of  $\geq 3.5 \mu\text{g/ml}$  helped predict clinical response at end of induction, with a sensitivity of 85.7% and a specificity of 81.8%.

**Figure 5.2: Infliximab levels, as predictor of clinical response at end of induction**  
ROC: receiver-operated characteristic; AUC: area under the curve



**Figure 5.3: Adalimumab levels, as predictor of clinical response at end of induction**  
ROC: receiver-operated characteristic; AUC: area under the curve

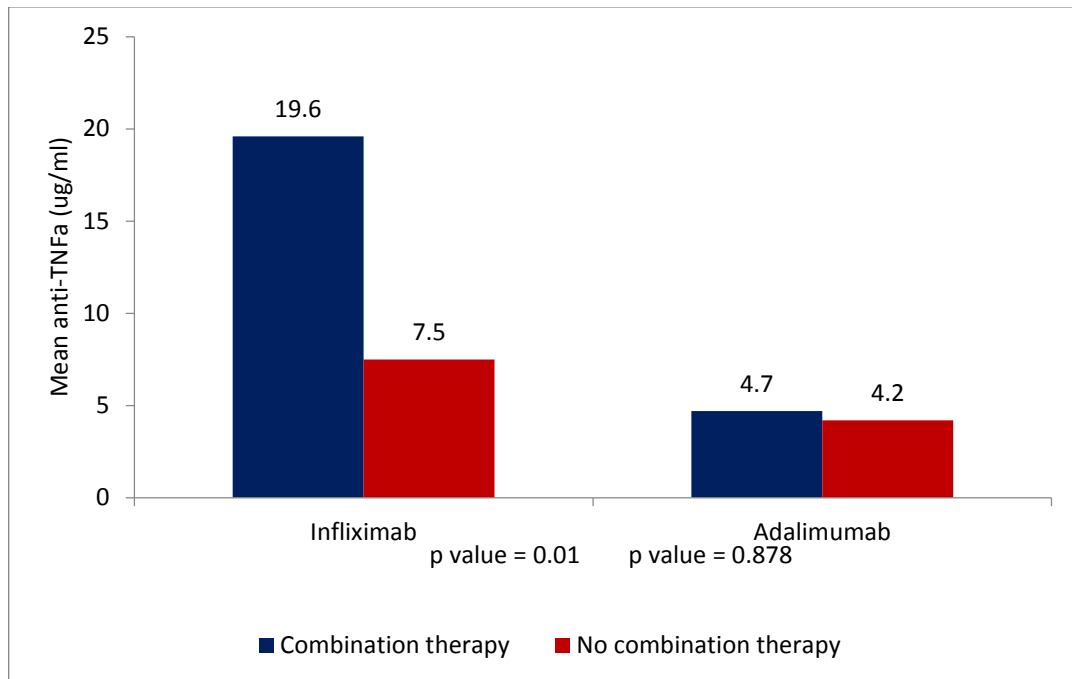


#### **5.4.4 Comparison of anti-TNF $\alpha$ trough levels between patients treated with and without immunomodulator combination therapy**

Patients treated with combination therapy had higher anti-TNF $\alpha$  trough levels, in comparison to those patients treated without combination therapy. For infliximab mean anti-TNF $\alpha$  trough level for patients treated with combination therapy, was 19.6  $\mu\text{g/ml}$  versus 7.5  $\mu\text{g/ml}$  for patients treated without combination therapy (p value = 0.01, 95% C.I: 3.3 to 20.9) (**Figure 5.4**). In addition, patients treated with combination therapy, were more likely to experience a clinical response at the end of induction therapy, 6/7 (85.7%) versus 6/10 (60%) for those treated without combination therapy, though not statistically significant (p value = 0.28). For adalimumab however, there was no statistical differences, mean ADL trough for those treated with combination therapy was 4.7  $\mu\text{g/ml}$  versus 4.2  $\mu\text{g/ml}$  for those treated without combination therapy (p value =0.87) (**Figure 5.4**). There was however an association between clinical response at induction therapy, with the use of combination therapy in patients treated with adalimumab. 3/5 (60%) of adalimumab patients, treated with combination therapy had a clinical response, versus 3/13 (23.1%) for those treated without combination therapy, though not statistically significant (p value = 0.15).

In terms of antibody formation, numbers were too small to draw any statistical conclusions. However for infliximab there was a suggestion of an association. No patients on infliximab combination therapy had antibody formation (0/7) versus 3/10 (30%) for those treated without combination therapy (p value =0.10). For adalimumab 1/5 (20%) of patients treated with combination therapy had antibody formation, compared to 2/13 (15.4%) for those treated without combination therapy.

**Figure 5.4: Comparison of mean anti-TNF $\alpha$  trough levels ( $\mu\text{g/ml}$ ) between those treated with/without combination therapy**

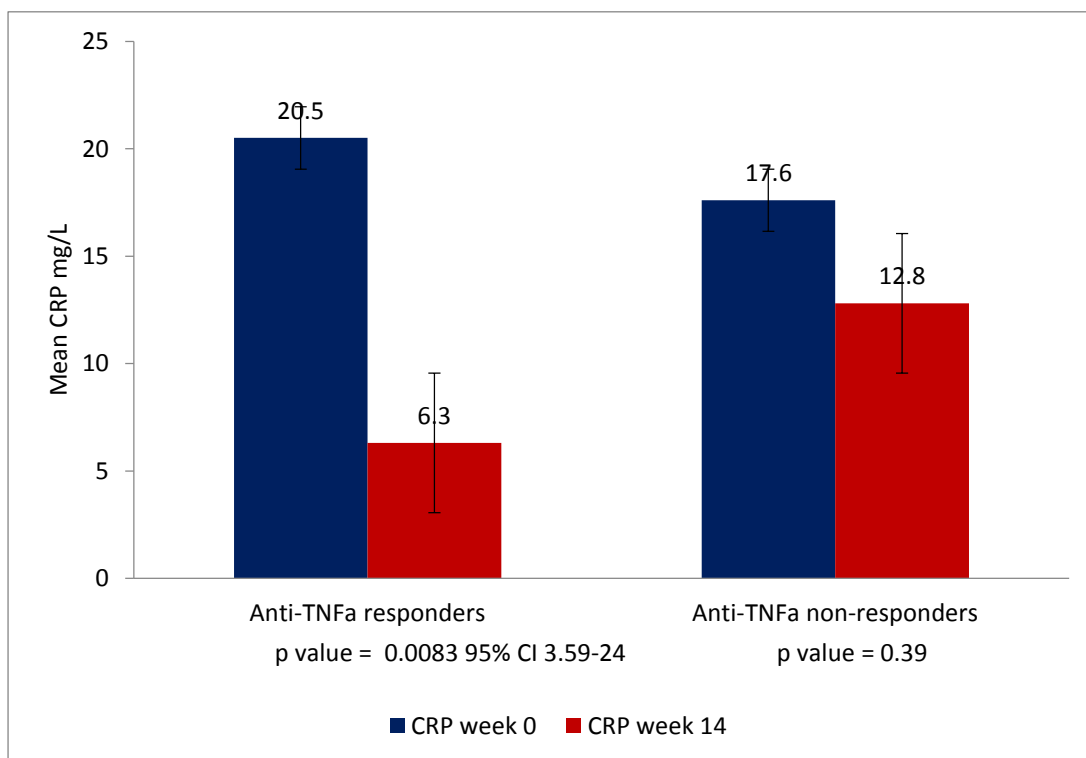


### **5.4.5 Relationship between anti-TNF $\alpha$ trough levels with clinical activity scores and biochemical response.**

There was clear correlation between anti-TNF $\alpha$  trough levels, with both clinical and biochemical response. As mentioned for the group of responders, who had higher anti-TNF $\alpha$  trough levels, in comparison to non-responders, there was significant improvement in clinical assessment tools. For responders, HBI improved from 9.7 to 3.4, in comparison to an actual increase in HBI for non-responders (p value = 0.004 95% CI -6.31 to -2.19) (**Table 5.2**). There were similar improvements in partial Mayo scores, for the group who responded, again this cohort, had higher anti-TNF $\alpha$  trough levels.

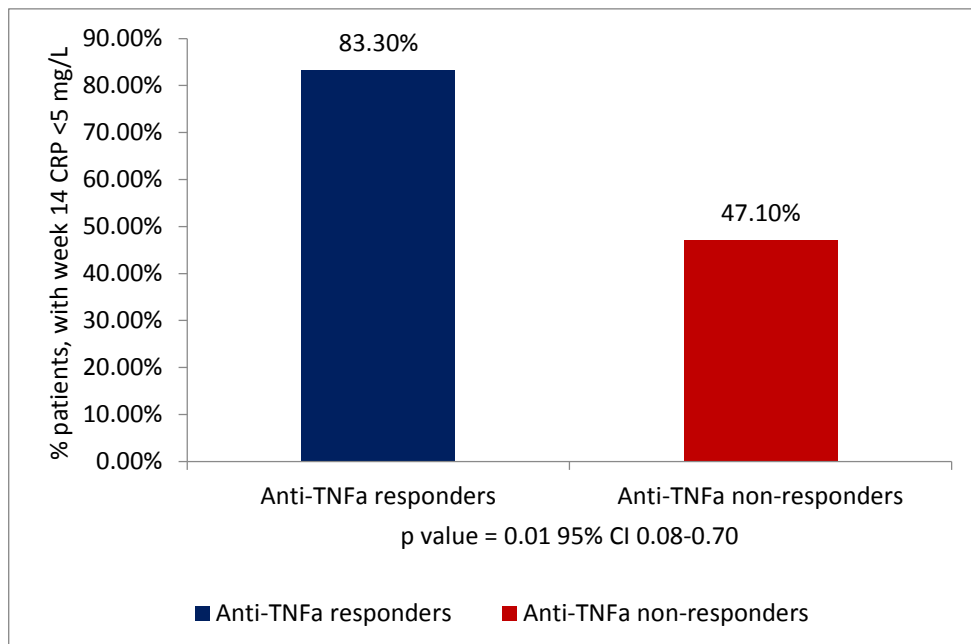
With regard to biochemical markers, there was a significant improvement, in mean CRP in the responders, compared to non-responders. Mean CRP for responder group was 20.5 mg/L pre induction, and 6.4 mg/L post induction (p value = 0.0083 95% C.I. 3.891 to 24.443). There was no statistical change in CRP rates in non-responders, mean CRP 17.6 mg/L pre induction, compared to 12.8 mg/L post induction, (p value = 0.39) (**Figure 5.5**). Furthermore week 14 CRP of less than 5 mg/L, has been shown to be associated with clinical response. For our cohort, 15/18 (83.3%) of responders, achieved this target, versus 8/17 (47.1%) for non-responders (p value = 0.01 95% C.I. 0.08 to 0.70 O.R .0.17) (**Figure 5.6**).

**Figure 5.5: Change in CRP for anti-TNFa responders and non-responders at end of Induction therapy**





**Figure 5.6: Comparison in rates of Week CRP <5 mg/L at end of induction therapy between anti-TNFa responders and non-responders**



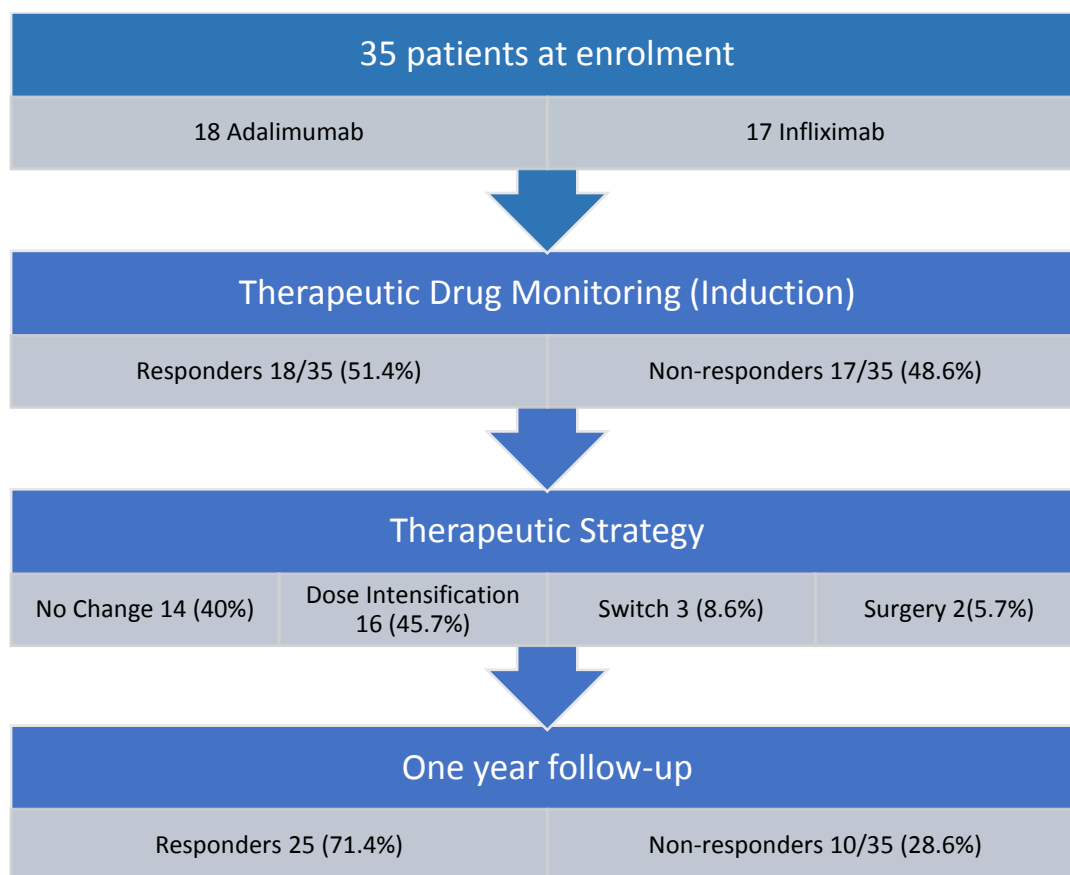
#### **5.4.6 Level of anti-TNFa antibody formation**

Antibody formation occurred in 6 patients (17.1%) overall. Antibody development was similar for Infliximab (16.6%) and Adalimumab (17.6%), with 3 patients each with detectable antibodies after induction.

#### **5.4.7 Therapeutic strategy at end of Induction therapy**

Depending on the overall clinical picture, biochemical markers, recent endoscopic assessment, as well as the information provided by TDM, patient's management was reviewed at the end of induction therapy and tailored accordingly (**Figure 5.7**).

**Figure 5.7: Patient flow chart**



The therapeutic strategy chosen for each group was: 14/35 (40%) no change in treatment required, 16/35 (45.7%) increase anti-TNF $\alpha$  dose or decrease in infusion interval, 2/35 (5.7%) switch to another anti-TNF $\alpha$  drug, 1/35 (2.9%) switch to non-anti-TNF $\alpha$  (ustekinumab) (**Table 5.3**). 2/35 patients (5.7%) required surgical intervention, after being assessed for secondary LOR to anti-TNF $\alpha$  therapy. 6/35 (17.1 %) had to stop anti-TNF $\alpha$  therapy, due to side-effects. These include one case of sinusitis, one arthropathy, one hepatotoxicity, and 2 unresolved pneumonias.

**Table 5.3: Therapeutic strategy for each group**

<i>N</i>	<i>Infliximab</i>	<i>Adalimumab</i>	<i>Total</i>
No change	17 (45.6%)	18 (51.4%)	35
Dose escalate	10 (58.8%)	4 (22.2%)	14 (40%)
-Regain response	6 (35.3%)	10 (55.6%)	16 (45.7%)
Switch	5 (83.3%)	6 (60%)	(11) (68.8%)
Surgery	1 (5.9%)	2 (22.2%)	3 (8.6%)

### **5.4.8 Results at one year follow-up.**

At one year, 25/35 (71.4%) of the cohort had a sustained clinical response (HBI of  $\leq 3$  or a partial Mayo score  $\leq 4$  or a reduction in clinical score of  $>30\%$  from baseline), 13/17 infliximab patients (76.5%), and 12/18 (66.6%) adalimumab patients. Overall secondary LOR occurred in 29% of our cohort.

Analysing the results, patients who were well at the end of the one year follow-up had marked reduction in clinical, endoscopic and biochemical scores, compared to non-responders (**Table 5.4**). Mean HBI improved from 9.2 to 2.3, compared to an increase from 7.6 to 10 for non-responders ( $p$  value = 0.0001 95% C.I -9.7 to 05.7). Similarly for endoscopic scores, SES-CD improved from 10.7 to 2.6 at 12 months, for responders, compared to an increase in responders, 18.2 from 12.4 (  $p$  value = 0.0001 95% C.I. -20.5 to -10.6). For UC, there was clear improvements, with a reduction in mean Mayo endoscopy sub score from 2.6 to 0.8 for non-responders, compared to an increase in non-responders, 3.0 from 2.4 ( $p$  value = 0.001 95% C.I -2.7 to -1.6). Biochemical markers also illustrated the improved outcomes for responders, with a reduction in mean CRP from 20.2 mg/L to 6.7 mg/L, compared to an increase for non-

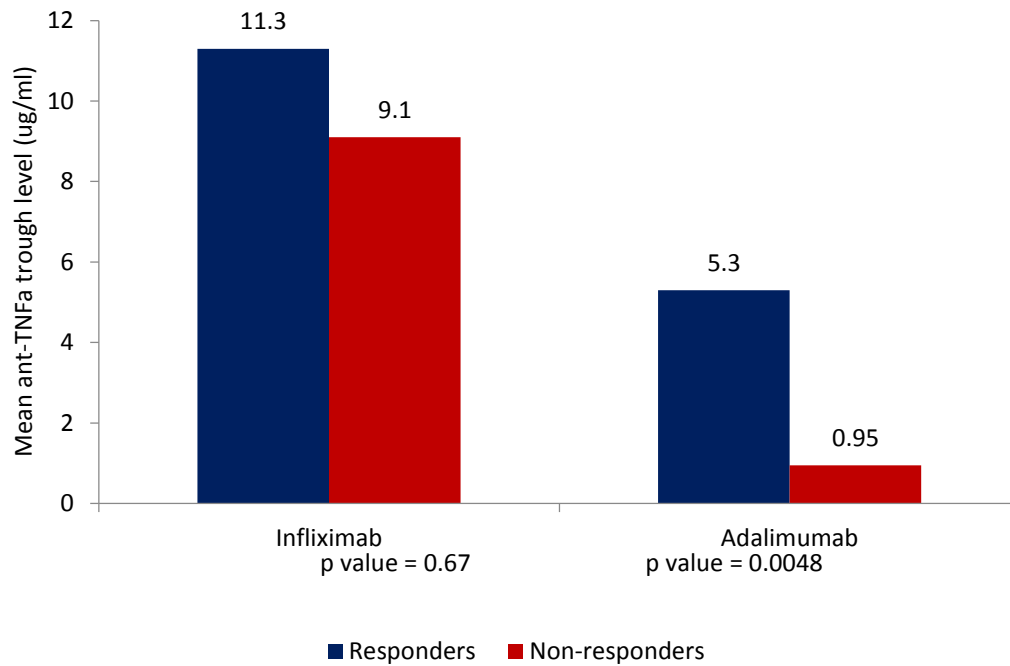
responders, 21.6 µg/ml from 14.6 µg/ml (p value =0.03 95% C.I. -28.4 to -1.3). There was in addition, a difference in mean adalimumab trough levels, at induction in responders compared to non-responders, 5.3 µg/ml compared to 0.95 µg/ml ( p value =0.0048 95% C.I. 0.12 to 9.1) (**Figure 5.8**). There was no difference in mean infliximab trough levels, likely due to small numbers involved, 11.3 µg/ml for responders, compared to 9.1 µg/ml for non-responders ( p value =0.67).

**Table 5.4: One year outcomes for cohort who had TDM performed at end of induction therapy**

<i>1 year outcomes</i>	<i>Well</i>	<i>Unwell</i>	<i>Total</i>	<i>P value</i>
N	25 (71.4%)	10 (28.6%)	35	
Mean age	40	41	40.3	0.76
Gender (female)	14 (56%)	8 (80%)	22	0.20
Duration of Disease	7.6	10.5	8.4	0.40
Crohn's	18 (78.3%)	5 (21.7%)	23	0.22
-Ulcerative colitis	7 (58.3%)	5 (41.7%)	12	
Infliximab	13 (76.4%)	4 (23.5%)	17	0.54
-Adalimumab	12 (66.7%)	6 (33.3%)	18	
HBI Baseline	9.2	7.6		0.49
<b>HB 12 months</b>	<b>2.3</b>	<b>10.0</b>		<b>0.0001</b>
Partial Mayo Baseline	6.8	5.8		0.64
<b>Partial Mayo 12 months</b>	<b>4.3</b>	<b>6.4</b>		<b>0.02</b>
SES-CD Baseline	10.7	12.4		0.64

<i>1 year outcomes</i>	<i>Well</i>	<i>Unwell</i>	<i>Total</i>	<i>P value</i>
<b>SES-CD 12 months</b>	<b>2.6</b>	<b>18.2</b>		<b>0.0001</b>
Mayo endoscopy sub core baseline	2.6	2.4		0.55
<b>Mayo endoscopy sub score 12 months</b>	<b>0.8</b>	<b>3.0</b>		<b>0.001</b>
Mean CRP baseline (mg/L)	20.2	14.6		0.43
<b>Mean CRP 12 months (mg/L)</b>	<b>6.7</b>	<b>21.6</b>		<b>0.03</b>
Mean albumin baseline (g/L)	38.3	41.3		0.22
<b>Mean albumin 12 months (g/L)</b>	<b>43.6</b>	<b>38.3</b>		<b>0.0014</b>
Mean Infliximab Trough level (µg/ml)	11.3	9.1		0.67
Infliximab Antibody formation	1	2		0.52
<b>Mean Adalimumab Trough level (µg/ml)</b>	<b>5.3</b>	<b>0.95</b>		<b>0.0048</b>
Adalimumab Antibody formation	1	2		

**Figure 5.8: Relationship between mean anti-TNF $\alpha$  levels at induction, with one year outcomes**



### 5.4.9 Results of anti-TNF $\alpha$ dose intensification

For patients, who responded to intensification of anti-TNF $\alpha$  therapy (11/16), there was a significant reduction in mean HBIs from 9.8 to 2, compared to an increase from 8.5 to 11.5 for non-responders (p value =0.0001 95% C.I. -11 to -7.98) (**Table 5.5**). For patients (n=16) who had doses adjusted, clinical response (decrease of HBI  $\geq 3$  points for CD) was reached in 11/16 patients (68.8%) patients and remission (HBI  $\leq 4$  for CD) in 10/16 (62.3%) at the end of follow-up.

**Table 5.5: Comparison of clinical, biochemical, endoscopic, TDM data for responders/non-responders to anti-TNF $\alpha$  dose escalation**

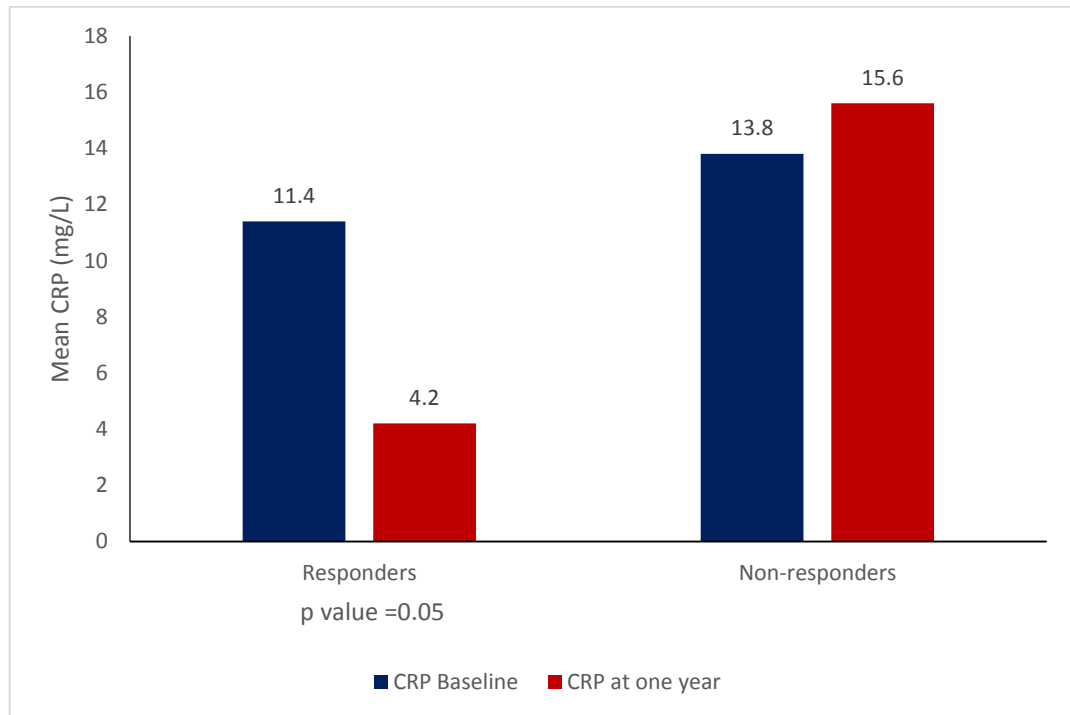
<i>Anti-TNF<math>\alpha</math> Dose intensification</i>	<i>Responders</i>	<i>Non-responders</i>	<i>P value</i>
N	11	5	
Baseline Mean CRP (mg/L)	11.7	13.8	0.74
Mean CRP 12 at months (mg/L)	4.2	15.6	0.0595
Baseline Mean Albumin (g/L)	38.3	41.2	0.19
Mean Albumin at 12 months (g/L)	42.5	40	0.28
HBI baseline	9.8	8.5	0.24
<b>HBI 12 months</b>	<b>2</b>	<b>11.5</b>	<b>0.0001</b>
Partial Mayo baseline	8	6.5	0.51
<b>Partial Mayo 12 months</b>	<b>2</b>	<b>7.3</b>	<b>0.06</b>
Mean SES-CD Baseline	8.3	17.5	0.13
<b>Mean SES-CD 12 months</b>	<b>2</b>	<b>22</b>	<b>0.03</b>
Mean Mayo endoscopy sub score Baseline	2.8	1	0.85
Mean Mayo endoscopy	2.7	3	

<i>Anti-TNF<math>\alpha</math> Dose intensification</i>	<i>Responders</i>	<i>Non-responders</i>	<i>P value</i>
sub core 12 months			
Mean Infliximab Trough Level ( $\mu\text{g/ml}$ )	10.4	12.3	0.78
Infliximab Antibody formation	0	2	
Mean Adalimumab Trough Level ( $\mu\text{g/ml}$ )	4.6	0.9	0.15
Adalimumab Antibody formation	0	2	

Additionally there was a significant change in biochemical markers in patients who regained response, post intensification of anti-TNF $\alpha$  therapy, with a reduction in mean CRP from 11.4 mg/L to 4.2 mg/L, compared to an increase for non-responders, 15.6 mg/L, from 13.8 mg/L ( p value =0.0595) (**Figure 5.9**). There were no statistical changes in serum albumin levels.



**Figure 5.9: Comparison of change in mean CRP post anti-TNF $\alpha$  intensification between responders and non-responders**



#### **5.4.10 Relationship between anti-TNF $\alpha$ trough and antibody levels, with dose intensification.**

There was no difference in infliximab trough levels, at the end of induction between those who responded to anti-TNF $\alpha$  dose intensification, and those that didn't. For adalimumab there was a suggestion, that patients who didn't respond to anti-TNF $\alpha$  dose intensification, had lower trough levels at induction, compared to responders, 0.9  $\mu$ g/ml versus 4.6  $\mu$ g/ml ( p value =0.15). Finally 2/5 (40%) of non-responders to anti-TNF $\alpha$  dose intensification had ADA compared to 1/11 (9.1%) for responders, though not statistically significant (p value = 0.16).

## 5.5 Discussion

Primary loss of response, to anti-TNF $\alpha$  therapy has significant implications for patient outcomes. Our study confirms the impact this has on patients with IBD. Our study showed a clinical response rate of 51.4%, with a significant difference in response between patients treated with adalimumab and infliximab. This is despite the fact that the infliximab group, had a more severe inflammatory burden, with higher CRP levels, as well as a more aggressive phenotype with higher rates of penetrating disease, as well as being more likely to have received previous anti-TNF $\alpha$  therapy. There is some evidence that for patients with UC in particular, response rates to adalimumab are reduced in comparison to infliximab. A recent Danish cohort study, showed that in comparison to infliximab, adalimumab-treated patients had higher rate of all-cause hospitalization (hazard ratio [HR], 1.84; 95% CI, 1.18-2.85) and a trend toward higher rate of UC-related hospitalization (HR, 1.71; 95% CI, 0.95-3.07), particularly in a stratum of patients on concomitant immunomodulator therapy [168].

A larger proportion of patients, in the adalimumab non-responder group had ulcerative colitis, compared to the responder group, 5/12 41.7% versus 1/6 16.7% (p value = 0.02 95% C.I. 0.12 to 1.21). Furthermore there was a lower inflammatory burden on patients treated with adalimumab, as well as fewer on combination therapy (mean HBI ADL 7.5 versus 11.5 for IFX, mean CRP 13.8 mg/L ADL versus 24.8 mg/L for IFX, and 27.7% on combination therapy for ADL, versus 41.2% for IFX).

Our study confirms the role of therapeutic drug monitoring in helping predicting primary clinical response. Infliximab patients who responded at the end of induction therapy, had improved trough levels, compared to non-responders. In addition there was a trend towards an association, between adalimumab trough levels, and clinical

response. These findings are supported from other similar studies, suggesting that aiming for therapeutic trough levels, is associated with overall better response rates, and clinical outcomes. For example, Kobayashi et al have shown that week 2 trough level was significantly associated with 14-week clinical remission [102]. Furthermore it's been established that sub-therapeutic anti-TNF $\alpha$  levels and or anti-TNF $\alpha$  antibody formation, helps predict primary non-response anti-TNF $\alpha$  therapy. As mentioned above, post hoc analysis of the Karmiris trial, has shown that that in a cohort of Crohn's patients treated with adalimumab week 4 trough levels of less than 5  $\mu\text{g/ml}$  are associated with an increased future risk of antibodies to adalimumab formation (HR: 25.12; 95% CI: 5.64–111.91;  $p = 0.0002$ ). These patients were found to have higher CRP levels, and greater risk of future gut inflammation [119].

There is also evidence available to support the idea that adalimumab concentrations post induction, help predict short term mucosal healing. A recent study by Papamichael et al has shown in a cohort of 43 UC patients, treated with adalimumab, that higher adalimumab trough levels are associated with short term mucosal healing (STMH) [169]. ADL concentration  $\geq 7.5 \mu\text{g/ml}$  at week 4 (odds ratio [OR]: 15.7; 95% CI: 1.3-185;  $p = 0.029$ ) and baseline endoscopic Mayo score 3 [OR: 0.13; 95% CI: 0.02-0.98;  $p = 0.047$ ] were identified as factors independently associated with STMH. A French study has shown, that therapeutic drug monitoring of infliximab helps strongly predict the likelihood of mucosal healing after infliximab intensification for both patients with UC and CD [114]. Thus there is a clear role, for therapeutic drug monitoring to be incorporated into the treatment algorithm when using anti-TNF $\alpha$  therapy. Going forward, there is ongoing work at defining optimal trough levels, and targets, when using anti-TNF $\alpha$  therapy. As mentioned in the opening chapter, Ungar et al propose that serum levels of 6-10  $\mu\text{g/ml}$  for infliximab and 8-12  $\mu\text{g/ml}$  for

adalimumab are required to achieve mucosal healing in 80%-90% of patients with IBD [116].

Our study also supports, the idea that like biochemical markers, such as CRP, anti-TNF $\alpha$  trough and antibodies levels, can help guide and predict treatment response. For our cohort mean trough levels, were considerably higher in non-responders, compared to responders, for both CD and UC. Mean infliximab and adalimumab trough levels, for primary responders, and non-responders, was 16  $\mu$ g/ml versus 6  $\mu$ g/ml, and 5  $\mu$ g/ml versus 3  $\mu$ g/ml respectively. In addition, a higher percentage of responders, achieved a week 14 CRP of less than 5 mg/L. It's worth noting there was a delta decrease in CRP for anti-TNF $\alpha$  non-responders, though not as impressive compared to anti-TNF $\alpha$  responders. There is ample evidence of the literature supporting a relationship between clinical response, anti-TNF $\alpha$  trough levels, and biochemical markers like CRP [66]. However as mentioned previously cost benefit analysis still favours CRP as a more practical and widely available predictor of disease activity and LOR.

TDM traditionally allows for doses to be adjusted or treatment to be tailored, such as the introduction of immunomodulators, to reduce antibody formation and thereby improve anti-TNF $\alpha$  trough levels. It may also allow for more cost effective use of anti-TNF $\alpha$  therapy, helping to recognise situations, where it's best to consider switching within anti-TNF $\alpha$  class, or to consider alternative agents. The accepted advantage of TDM is that it helps explore an immune basis behind primary LOR, taking into account underlying anti-TNF $\alpha$  pharmacokinetics. However, only 17% of our cohort had significant drug antibodies and antibody formation wasn't predictive of outcome. While the impact of antibody formation was less clear in our study there was a definite association between trough levels and clinical and biochemical outcome. There may be other important factors at play clinically, which may have a significant impact on

trough levels. As such the need for antibody testing in addition to trough levels may not add significantly to the therapeutic paradigm.

Our ROC analysis suggests a target IFX and ADL trough level of 4.8 µg/ml and 3.5 µg/ml could help clinicians predict response and offer a valid target for tailored therapy based on TDM after induction. Our study also adds further weight to the growing awareness that target / optimal trough levels rather than avoidance of low or suboptimal levels is likely to have a significant impact on clinical outcomes.

In addition this study confirmed the benefits of combination therapy, with higher trough levels noted in patients, treated with infliximab in combination with immunomodulators. Furthermore there was a suggestion of improved outcomes in patients treated with this strategy. These results are similar to other studies which confirm the role for combination therapy in reducing antibody formation, and improving anti-TNFα trough levels [107-108].

Overcoming primary non-response to anti-TNFα is a major battle in the management of IBD. Failure to induce remission is associated with worse outcomes including increased surgical rates. In all, 4 patients from our cohort required surgical intervention at the end of induction therapy, due to a lack of response to their anti-TNFα therapy.

Our study confirms the role for dose intensification of anti-TNFα therapy, in patients who have suboptimal response at the end of induction, with 68.9% of patients responding to this strategy. This is particularly true for adalimumab, where overall response improved from 33.3% at the end of induction, to 66.6% at one year follow-up. For adalimumab, dose intensifying can help regain clinical response, avoiding the need to switch agents. In terms of the use of TDM, our study showed that there was a

suggestion, those patients who didn't respond to adalimumab dose intensification, had lower trough levels at induction, compared to responders, 0.9 µg/ml versus 4.6 µg/ml.

As mentioned a meta-analysis from 2011 has showed that the mean percentage of patients who required dose intensification among primary responders to adalimumab was 37% and the annual risk was 24.8% per patient-year [154]. When considering initial responders and patients with primary non-response, the mean percentage of patients who needed an adalimumab dose escalation was 21.4% and the annual risk was 24.4% per patient-year. Pooled analysis showed that dose escalation permitted response to be regained in 71.4% and remission in 39.9% of patients. Thus the combination of clinical, biochemical, endoscopic evaluations and the increasing important role of TDM may help address the difficulties of LOR to anti-TNF $\alpha$  and help develop strategies to induce and maintain long lasting clinical remission, and help achieve mucosal healing.

Our data also suggests that while induction TDM is useful in managing primary LOR, with 68% response to dose intensification, induction TDM, as with stand-alone TDM, is not predictive of secondary LOR. There was no clear association between infliximab or adalimumab induction trough's or ADA's and response at 12 months. This is not surprising as compliance, disease activity and ADA's may all vary over time. As such, our data suggests both induction and secondary LOR 'targeted' TDM is warranted to optimise patient care.

Limitations of this study include the small sample size, which may limit extrapolation of this data, to larger populations. In addition the fact that the patients weren't randomised against patients treated in the standard fashion, i.e. doses adjusted based on clinical assessment, without the use of TDM. Such a comparison would have been useful to explore the perceived benefits of TDM further and in particular the treat

to target approach. In addition sub-analysis of cost savings associated with TDM would also have been helpful. Never the less, this study adds to the weight of opinion that suggests some potential benefit of TDM, when used in a thoughtful and considered fashion.

Further study is required to confirm the above findings, with larger randomised clinical trials required.

## **5.6 Conclusions**

In summary this study suggests a role for therapeutic drug monitoring in the management of patients with IBD. It has demonstrated a clear link, between clinical and biochemical response with anti-TNFa trough levels. There is now growing evidence that performing therapeutic drug monitoring during the induction period, will identify patients at risk of LOR, and who would best benefit from dose intensification, in a clinically guided fashion. Randomized controlled clinical trials, are needed to further confirm the potential of this approach

# **CHAPTER 6- Positive impact of therapeutic drug monitoring in assessing secondary loss of response to maintenance anti-TNF $\alpha$ therapy in inflammatory bowel disease.**

## **6.1 Introduction**

As discussed previously anti-TNF $\alpha$  therapy has greatly improved outcomes for patients with inflammatory bowel disease. There has been a paradigm shift, with earlier introduction of anti-TNF $\alpha$  therapy, to reduce complications and increase the likelihood of mucosal healing, all of which help to alter the natural history of the disease [170].

However unfortunately overtime response can be lost, leading to treatment failure. Loss of response (LOR) may be primary or secondary. There are difficulties around strict definitions for LOR [60]. Primary LOR refers to the situation, whereby patients fail to respond to anti-TNF $\alpha$  during or at the end of standard induction therapy, typically up to 12-14 weeks. Secondary LOR refers to the scenario where patients initially respond to anti-TNF $\alpha$  therapy, but overtime gradually lose response. The incidence can vary between 7–25% if measured by the rate of anti-TNF $\alpha$  discontinuation [61-62]. This is similar to our cohort studies, showing high LOR rates, with a LOR rate of 40% over a one year period. Patients may experience a reduced or a diminished clinical response. This can be associated with a flare of symptoms, need for further steroid exposure, and further IBD related complications.



Defining secondary LOR is important. Definitions though have been variable, and quite often have been derived from clinical trial data. There are several different interpretations as to defining the CDAI at which clinical response or non-response occurs. For example for Crohn's disease, it has been defined as an increase in CDAI of greater than 70 points from a pre-induction score, combined with a total score of greater than 175 [171]. Another definition is an increase in CDAI of  $\geq 35\%$  from baseline, or at a clinical level, the need to introduce a new treatment for active disease [62]. Thia et al, have published a study of trial data looking at defining the optimal response criteria for the CDAI in induction studies for mild-to-moderately active Crohn's [172]. Treatment effect differences in placebo-controlled studies were maximized by response definitions that incorporated either a decrease CDAI  $>$  or  $=70$  points for the last two consecutive visits or decrease in baseline CDAI  $>$  or  $=100$  points, and remained optimal when evaluated for the composite effect of time, baseline activity, and prior resections. A decrease in baseline CDAI  $>$  or  $=100$  points had some advantages over a decrease CDAI  $>$  or  $=70$  points over two visits in terms of study efficiency, as it produced a lower control response rate and was not influenced by any of the baseline factors.

It's important when evaluating patients with secondary LOR, to consider alternative aetiologies. For example non-IBD related factors, such as infection, or functional symptoms like irritable bowel syndrome. Furthermore there are certain situations, where the non-inflammatory attributes, of IBD can lead to an increase in symptoms, and presumed anti-TNFa failure. For example as mentioned previously, fibrostenotic disease is unlikely to respond adequately to anti-TNFa therapy [63].

In addition a number of studies have shown that approximately one-third of patients on maintenance therapy lose response to infliximab over the first year of treatment [173-174]. This similar to our data, showing a secondary LOR rate of 27%

for our cohort, who had stand-alone TDM performed. Regarding adalimumab and secondary LOR, a meta-analysis has shown an annual risk of 20.3%/per patient years [154].

In terms of a disparity in time to secondary LOR between infliximab and adalimumab the literature is conflicting. One Canadian group have shown that for Crohn's disease, the time to loss of response was shorter in patients treated with adalimumab compared to those treated with infliximab [175]. Median time to secondary loss of response was longer for infliximab patients (99.3wk, IQR 55.7-168.5) compared to both adalimumab patients naïve to anti-TNF $\alpha$  therapy (58.9wk, IQR 29.0-85.7) ( $p=0.03$ ), and adalimumab patients with prior anti-TNF $\alpha$  exposure (52.7wk, IQR 20.1-85.0) ( $p<0.001$ ). However for UC, the same group have shown in a real-life cohort of anti-TNF-naïve primary responders with UC, that the proportion of secondary loss of response and the time to secondary loss of response are similar for adalimumab and infliximab [176]. In a cohort of 102 primary anti-TNF $\alpha$  responders, a total of 21/36 (58.3%) adalimumab-treated patients and 39/66 (59.1%) infliximab-treated patients experienced a secondary loss of response during maintenance therapy.

A number of factors are associated or are thought to help predict secondary LOR to anti-TNF $\alpha$  therapy. Smoking is strongly associated with secondary LOR to anti-TNF $\alpha$  therapy. One study has shown that patients treated with adalimumab who smoked were statistically more likely to lose response, and in addition, have a shorter duration of clinical response, 15.8 vs. 36.3 weeks ( $p = 0.013$ ) [177]. Disease characteristics, may also impact on clinical response. Subgroup analysis of the CHARM data, for Crohn's disease, has shown that longer disease duration and higher clinical scores were associated with an increased likelihood of secondary LOR [178].

There is increasing evidence that immunogenicity can have a significant impact on anti-TNF $\alpha$  response rates overtime. As mentioned antibodies may bond to the F (ab) fragment of the anti-TNF $\alpha$  molecule, neutralising its clinical effects [105]. The formation of antibodies to anti-TNF $\alpha$  can also lead to reduced circulating levels of anti-TNF $\alpha$  in the body. This has been shown to be associated with a recurrence of IBD related inflammation, and clinical flare of disease [73, 179].

Therapeutic drug monitoring as mentioned involves measurement of an individual's anti-TNF $\alpha$  trough and antibody levels, with the aim of adjusting (intensifying) doses, or switching to alternative agents, where appropriate to help regain clinical response, and reduce the risk of further complications. As discussed previously a retrospective Israeli study suggests that trough levels of drug or anti-TNF $\alpha$  antibodies may guide therapeutic decisions for more than two-thirds of inflammatory bowel disease patients with either clinically suspected or definite inflammatory loss of response to therapy [126]. This is similar to our data, suggesting a beneficial role, for TDM during induction.

A recent study has also shown that a pro-active approach to TDM rather than a reactive approach maybe more beneficial. In a retrospective study of 264 patients, treated with infliximab, multiple Cox regression analysis independently associated proactive drug monitoring, compared to reactive monitoring, with reduced risk for treatment failure (hazard ratio [HR], 0.16, 95% CI, 0.09-0.27;  $p < .001$ ) [180]. Further work is required to confirm this proactive approach.

## 6.2 Aims

- 1 To prospectively evaluate whether TDM is a useful tool to investigate, secondary LOR to infliximab and adalimumab
- 2 To investigate whether therapeutic decisions based on TDM, can help patients regain response.
- 3 To prospectively gather real life data outside of the environment of a clinical trial.
- 4 To obtain information on an Irish cohort.

## 6.3 Materials & Methods

This was a prospective interventional, single centre study, performed at Tallaght Hospital, Dublin, Ireland. Patients were recruited from the gastroenterology department at Tallaght Hospital, from September 2015 to April 2016. Inclusion criteria were all patients older than 17 years old with IBD, who were clinically (based on HBI or partial Mayo scores of > 4 and >2 respectively) felt to be experiencing a secondary LOR to anti-TNF $\alpha$  drugs, either infliximab or adalimumab, during the study period.

Patients had serum biochemical markers measured, including CRP and albumin, and drug antibody and trough levels performed when they were first assessed for secondary LOR to anti-TNF $\alpha$  therapy. In addition an endoscopic assessment of inflammation took place, with measurement of SES-CD and Mayo scores, for CD and UC respectively.

Patients were excluded if they were experiencing a drug reaction or recurrent infection rather than LOR.

Patients treatment was adjusted based on TDM. For those with LOR and low trough without antibodies, had doses intensified, while those with low trough and antibody formation, had immunomodulators added, or a switch in therapy. Patients with adequate trough level, with or without antibodies, were switched to alternative anti-TNF $\alpha$  agents, or IL 12-23 inhibitor ustekinumab, after an appropriate six week wash-out period.

Patients were followed for a one year period, from their initial assessment for secondary LOR to assess outcomes. At one year review to aid subgroup analysis, patients were divided into a well group, that didn't require change in therapy or breakthrough steroid usage, versus an unwell group, that required intervention in the form of surgery, anti-TNF $\alpha$  dose intensification or a switch in therapy.

Anti-TNF $\alpha$  trough and antibodies were measured as described in Chapter 2, based on the ELISA protocol adapted from Ungar et al [70].

Continuous variables were expressed as the median and standard deviation and categorical variables as number and percentage. Mann–Whitney test was used to compare continuous variables and categorical variables were analysed by Fisher's exact test. A two-tailed  $P < 0.05$  was considered statistically significant. A ROC analysis was performed for evaluation of the accuracy of prediction of clinical response by infliximab and adalimumab levels. Statistical analysis was performed using MedCalc Statistical Software version 17.4 (MedCalc Software bvba, Ostend, Belgium; <http://www.medcalc.org>; 2017).

## 6.4 Results

### 6.4.1 Baseline Characteristics

Baseline patient clinical characteristics are shown in **Table 6.1**. In all 46 patients were recruited; 40 with Crohn's disease, and 6 with Ulcerative colitis. 36 patients were treated with adalimumab, 10 patients with infliximab. Unusually all 10, of the patients treated with infliximab, had underlying Crohn's disease. Mean age for the cohort was 40.9 years, 26 (56.5%) were female, 7 (15.2%) were on immunomodulators, and 11 (23.9%) had prior anti-TNF $\alpha$  exposure. Mean duration of anti-TNF $\alpha$  use, was 3.2 years (range 0.5-8). 12/30 (40%) and 3/10 (30%) were on dose intensified adalimumab 40mg weekly and infliximab 5mg/kg every 6 weeks respectively. Overall clinical, endoscopic and biochemical activity for the cohort at baseline was, HBI 11.9 (range 5-19), partial Mayo 6.5 (3-9), SES-CD 8.5 (0-20), Mayo endoscopy sub-score 2.7 (2-3), CRP 10.9 mg/L (1-85.2 mg/L) and serum albumin 41.1 g/L (17-50 g/L).

**Table 6.1: Baseline Patient Characteristics for cohort evaluated for secondary LOR**

	<i>Infliximab</i>	<i>Adalimumab</i>	<i>Total</i>	<i>P value</i>	<i>OR (95% C.I.)</i>
Number	10 (21.7%)	36 (78.3%)	46		
Mean Age	35.1	43.4	40.9	0.11	
Gender (female)	5 (50%)	21 (58.3%)	26 (56.5%)	0.33	
CD	10 (100)	30 (83.3)	40 (87%)	0.17	

	<i>Infliximab</i>	<i>Adalimumab</i>	<i>Total</i>	<i>P value</i>	<i>OR (95% C.I.)</i>
Disease Duration (years)	9.9	11.1	9.8	0.42	
Age at onset					
A1	3 (30%)	6 (20%)	9 (22.5%)	0.22	
A2	7 (70%)	21 (70%)	28 (70%)	0.25	
A3	0 (0%)	3 (10%)	3 (7.5%)	0.31	
Disease Location					
L1	0 (0%)	6(20%)	6 (15%)	0.13	
L2	2(20%)	2 (6.7%)	4 (10%)	0.18	
L3	7 (70%)	20 (66.7%)	27 (67.5%)	0.21	
L4	1 (10%)	2 (6.7%)	3 (7.5%)	0.34	
Disease Behaviour					
B1	3(30%)	9 (30%)	12 (30%)	0.38	
B2	4(40%)	13 (43.3%)	17 (42.5%)	0.42	
B3	3 (30%)	8 (26.7%)	11 (27.5%)	0.32	
Perianal	3 (30%)	6 (20%)	6 (22.5%)	0.22	
UC Severity					
E1	0	0	0		
E2	0	3 (50%)	3 (50%)		
E3	0	3 (50%)	3 (50%)		
Clinical Scores:					
-HBI	9.9	11.8	11.9	0.28	
-Partial Mayo	0	6.5	6.5		

	<i>Infliximab</i>	<i>Adalimumab</i>	<i>Total</i>	<i>P value</i>	<i>OR (95% C.I.)</i>
Severity of inflammation:					
-SES-CD	8.1	10	8.1	0.24	
-Mayo endoscopy score	0	2.7	2.7		
Smoking	0 (0%)	3 (8.3%)	3 (6.5%)	<b>0.001</b>	<b>9.8 (0.2-561)</b>
Combination therapy	1 (10%)	6 (16.7%)	7 (15.2%)	0.29	
<b>Prior anti-TNF<math>\alpha</math> use</b>	<b>7 (70%)</b>	<b>4 (11.1%)</b>	<b>11 (23.9%)</b>	<b>0.001</b>	<b>18.6 (3.4-102)</b>
Previous surgery	2 (20%)	14 (38.9%)	16 (34.8%)	0.12	
<b>Mean CRP (mg/L)</b>	<b>15.2</b>	<b>9.6</b>	<b>10.9</b>	<b>0.04</b>	
Mean serum albumin (g/L)	41.3	41.1	41.1	0.43	
<b>Mean Anti-TNF<math>\alpha</math> Trough Level (<math>\mu</math>g/ml)</b>	<b>8.1</b>	<b>4.5</b>	<b>5.3</b>	<b>0.0766</b>	
Anti-TNF $\alpha$ Antibody ( $\mu$ g/ml)	0.7	1.1	0.98	0.44	

There were no significant differences between patients treated with infliximab and adalimumab, in terms of age of onset of disease and disease location. More patients, treated with adalimumab were smokers compared to infliximab, 8.3% versus 0% (p value =0.001, 95% C.I. 0.74-1.10 OR 9.57). In addition patients treated with infliximab, had greater levels of prior anti-TNF $\alpha$  exposure, compared to adalimumab, 7/10 (70%) versus, 4/36 (11.1%) (p value = 0.001 95% C.I. 0.3-0.85 OR 18.6).



## 6.4.2 Mean adalimumab & infliximab trough and antibody levels at time of secondary loss of response

Mean adalimumab trough level was 4.5 µg/ml (IQR 0.44-7.5µg/ml), and 15/36 (42.9%) had a sub-therapeutic trough level less than 1 µg/ml and 9 patients (25.7%) had antibodies to adalimumab. Mean infliximab trough level was 8.1 µg/ml (IQR 1.9-14.5 µg/ml) and 2/10 (20%) had sub-therapeutic trough levels. There was no evidence of antibodies against infliximab in our cohort.

## 6.4.3 One year outcomes for patients assessed for secondary loss of response to adalimumab

Patient characteristics for the adalimumab well and unwell groups at one year are shown in **Table 6.2**.

**Table 6.2: One year outcomes for patients assessed for secondary loss of response to adalimumab**

<i>Adalimumab</i>	<i>Unwell Group</i>	<i>Well group</i>	<i>P value</i>	<i>OR (95% CI)</i>
N	26	10		
Age	43.7	39.5	0.53	
Gender (female)	16 (61.5%)	5 (50%)	0.54	

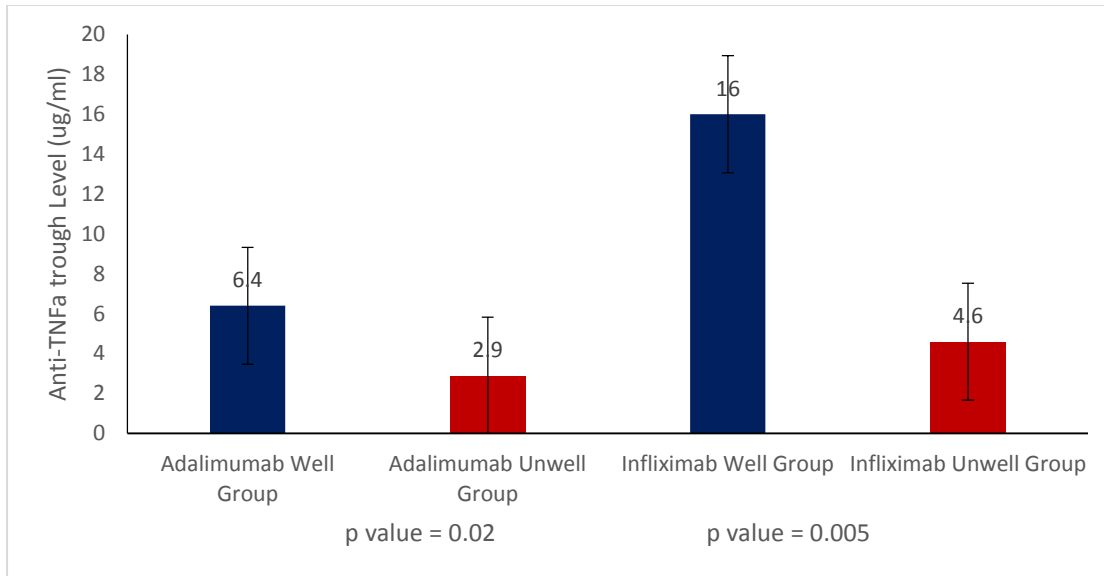
<i>Adalimumab</i>	<i>Unwell Group</i>	<i>Well group</i>	<i>P value</i>	<i>OR (95% CI)</i>
Crohn's	23/26 (88.55)	7/10 (70%)	0.19	
Disease Duration	9.9	11.5	0.66	
Immunomodulators	3/26 (11.5%)	3/10 (30%)	0.19	
Prior anti-TNF $\alpha$ use	2/26 (7.9%)	2/10 (20%)	0.31	
Adalimumab dose -40mg every other week	12/26 (46.2%)	6/10 (60%)	0.74	
Duration of Adalimumab use	3.28	3.10	0.85	
Prior surgery	11/26 (42.3%)	2/10 (20%)	0.22	
<b>CRP &lt;5 mg/L</b>	<b>11/26 (42.3%)</b>	<b>9/10(90%)</b>	<b>0.0089</b>	<b>0.08 (0.008-0.7)</b>
Mean CRP (mg/L)	11.5	4.7	0.11	
Mean Albumin (g/L)	40.3	43.4		
Clinical Scores:				
-HBI	14.1	5.6	<b>0.001</b>	
-Partial Mayo	6.5	6.5	0.42	
Inflammation:				
-SES-CD	8.9	4	<b>0.022</b>	
-Mayo	2.5	3	0.42	
Adalimumab Trough	2.90	6.38	<b>0.0265</b>	

<i>Adalimumab</i>	<i>Unwell Group</i>	<i>Well group</i>	<i>P value</i>	<i>OR (95% CI)</i>
Level (µg/ml)				
Adalimumab Antibody	1.01	0.94	0.60	

#### **6.4.4 Comparison of adalimumab trough levels, clinical, biochemical and endoscopic scores between well/unwell groups at one year post-secondary LOR**

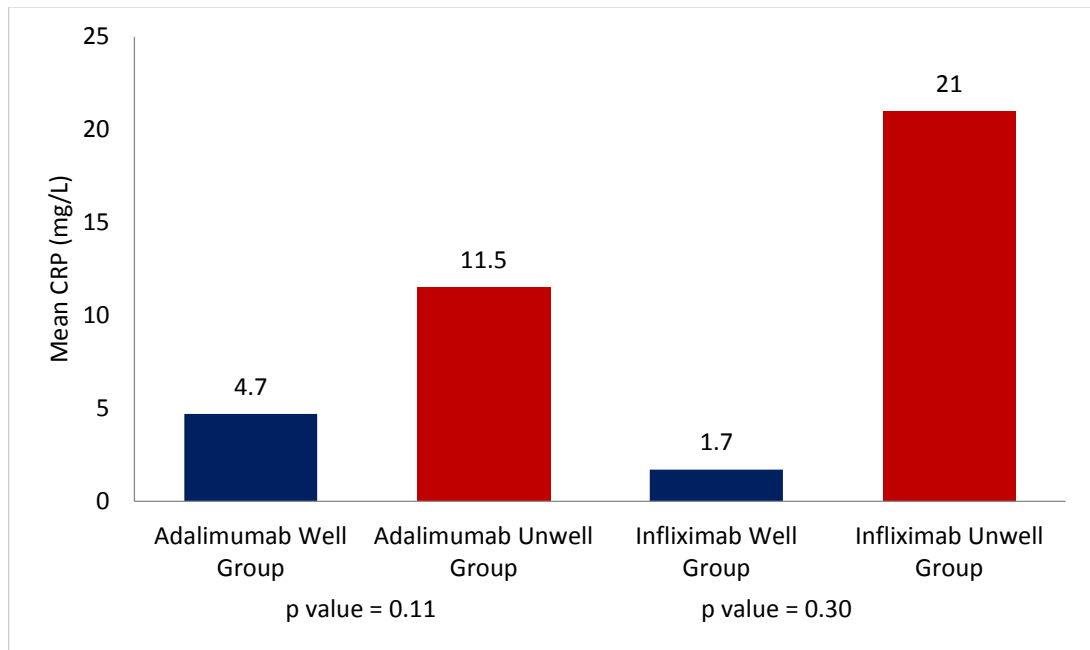
Higher baseline adalimumab trough levels, were noted in patients who were well or who had functional symptoms in the absence of inflammation, at one year follow-up compared to patients, who were unwell, and required change in therapy, mean trough 6.4 µg/ml (IQR 2.1-10.3) compared to 2.9 µg/ml (IQR 0.3-6.3) (p value = 0.0265 95% C.I. 0.4 to 6.5) (**Figure 6.1**).

**Figure 6.1: Relationship between anti-TNF $\alpha$  trough levels, with 1 year outcomes to infliximab and adalimumab, in patients assessed for secondary loss of response**



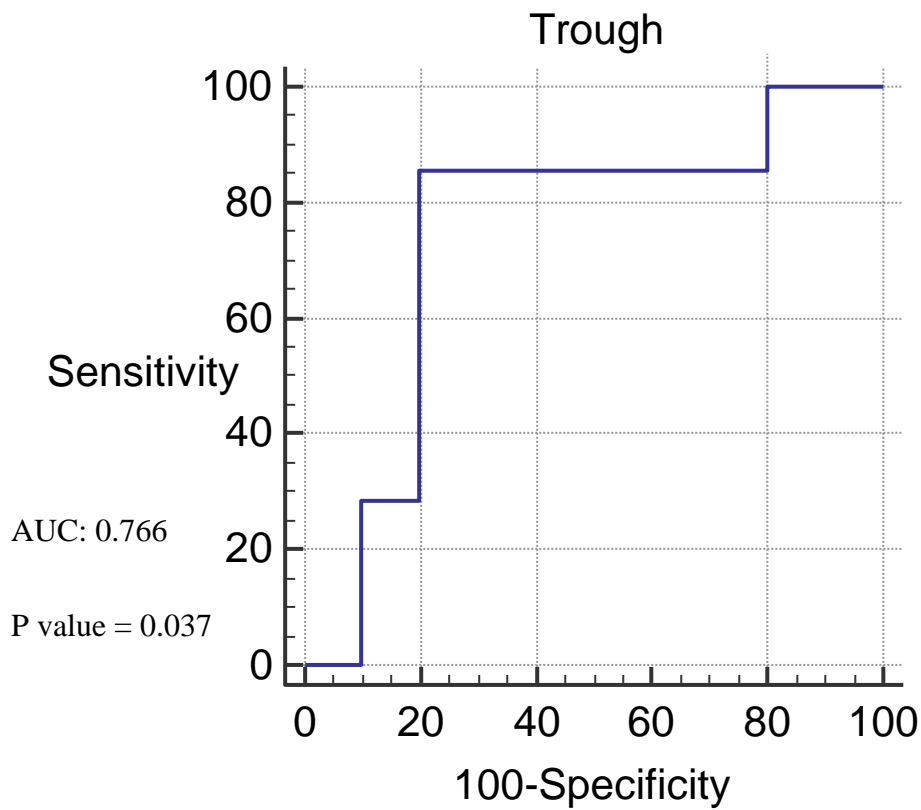
Patients treated with adalimumab who required a change in treatment (unwell group) were less likely to have evidence of biochemical remission, with only 11/26 (42.3%) having CRP <5 mg/L, at time of assessment, compared to 9/10 (90%) for the well group (p value = 0.0089 95% C.I -0.83 to 0.13, OR 0.08). Mean CRP for unwell group was 11.5 mg/L, compared to 4.7 mg/L, for the well group (p value = 0.11) (Figure 6.2). In addition the unwell group had higher clinical and endoscopic scores, compared to the well group, mean HBI 14.1 compared to 5.6 ( p value = 0.001 95% C.I -10.83 to 6.31), and SES-CD 8.9 compared to 4.0 (p value = 0.022 95% C.I. -8.98 to 0.075).

**Figure 6.2: Mean CRP for infliximab and adalimumab 1 year outcomes, in patients evaluated for secondary loss of response**



The area under the curve [AUC] for association of ADL level at secondary LOR with a good outcome was 0.766,  $p = 0.037$  (**Figure 6.3**). In addition ROC analysis, showed a trough level of 3.5  $\mu\text{g/ml}$  predicted clinical response at one year, following secondary LOR to adalimumab, with a sensitivity of 85.7% and a specificity of 81.8%.

**Figure 6.3: Adalimumab trough levels, as predictor of clinical response for patients experiencing secondary LOR: receiver-operated characteristic; AUC: area under the curve**



### **6.4.5 One year outcomes for patients assessed for secondary loss of response to infliximab**

Patient characteristics for the infliximab well and unwell groups are shown in **Table 6.3.**

**Table 6.3: Patient characteristics of infliximab good and bad outcomes**

<i>Infliximab</i>	<i>Unwell Group</i>	<i>Well group</i>	<i>P value</i>	<i>OR (95% CI)</i>
N	7	3		
Age	33.4	39	0.41	
Gender (female)	5 (71.4)	1 (33.3%)	0.19	
Crohn's	7 (100%)	3 (100%)		
<b>Disease Duration</b>	<b>9.1</b>	<b>19.6</b>	<b>0.01</b>	
Immunomodulators	0 (0%)	1 (33.3%)	0.21	
Prior anti-TNFa use	4 (57.1%)	2 (66.7%)	0.41	
Infliximab dose -5mg/kg every 8 weeks	6 (85.7%)	1 (33.3%)	0.12	
Duration of Infliximab use	2.8	4.7	0.24	
Prior surgery	1 (14.3%)	0 (0%)	0.17	
<b>CRP &lt;5 mg/L</b>	<b>3 (42.9%)</b>	<b>3 (100%)</b>	<b>0.01</b>	<b>0.06 (0.002- 1.7)</b>
Mean CRP (mg/L)	21.0	1.7	0.30	
Mean Albumin (g/L)	40.6	43.0	0.41	
<b>Clinical Scores:</b>				
<b>-HBI</b>	<b>11.6</b>	<b>6</b>	<b>0.07</b>	

<i>Infliximab</i>	<i>Unwell Group</i>	<i>Well group</i>	<i>P value</i>	<i>OR (95% CI)</i>
<b>Inflammation:</b>				
<b>-SES-CD</b>	<b>12.9</b>	<b>3.3</b>	<b>0.04</b>	
<b>Infliximab Trough Level (µg/ml)</b>	<b>4.6</b>	<b>16.0</b>	<b>0.005</b>	
Infliximab Antibody	0.8	0.6	0.42	

#### **6.4.6 Comparison of infliximab trough levels, clinical, biochemical and endoscopic scores between well/unwell groups at one year post-secondary LOR**

Similarly for infliximab higher baseline trough levels, were noted in patients who were well at one year follow-up compared to those who required change in treatment, 16.0 µg/ml (IQR 15-16.8) versus 4.6 µg/ml (IQR 1.1-6.1), (p value = 0.005 95% CI 4.5 to 18.3) (**Figure 6.1**). In addition patients treated with infliximab who were unwell, at one year follow-up had a reduced likelihood of baseline CRP <5 mg/L, 3/7 (42.9%) versus 3/3 (100%), p value = 0.01, OR 0.06 (**Table 6.3**). However sample size here is very small, making any statistical analysis difficult and certainly influences interpretation of these results.

#### **6.4.7 Therapeutic strategy chosen at time of secondary LOR**

Depending on the overall clinical picture, biochemical markers, recent endoscopic assessment, as well as the information provided by TDM, patient's management was



reviewed and tailored accordingly. In general, in the presence of ADA and low trough levels, an immunomodulator is introduced, or if there is a contraindication, switched to an alternative agent. If there is no ADA formation, and low trough levels, doses are intensified. The therapeutic strategy chosen for the cohort was : 13/46 (28.3% ) no change in treatment required, 12/46 (26.1%) dose intensification (increase anti-TNFa dose or decrease infusion interval), 12/46 (26.1%) switch to another anti-TNFa drug, 5/46 (10.9%) switch to non-anti-TNFa (ustekinumab) after an appropriate six week wash-out period, 2/46 (4.3%) had an immunomodulator added (**Table 6.4**). In all 17/46 patients (17.4%) required surgical intervention, after being assessed for secondary LOR to anti-TNFa therapy.

**Table 6.4: Therapeutic Strategy chosen at time of secondary loss of response assessment**

	<i>Infliximab</i>	<i>Adalimumab</i>	<i>Total</i>
<b>N</b>	10	36	46
<b>Well/functional</b>	3 (30%)	10 (27.7%)	13 (28.3%)
<b>Dose escalate</b>	3 (30%)	9 (25%)	12 (26.1%)
<b>-Regain response</b>	2 (20%)	7 (19.4%)	9 (19.6%)
<b>Switch</b>	3 (30%)	14 (38.9%)	17 (35.4%)
<b>Surgery</b>	2 (20%)	6 (16.7%)	8 (17.4%)

## 6.4.8 Clinical outcomes for different therapeutic strategies

There was no difference in clinical outcomes, between the various strategies. For patients who had doses adjusted, clinical response (decrease of HBI  $\geq 3$  points for CD) was reached in 9/12 (75%) of patients and remission (HBI  $\leq 4$  for CD) in 7/12 (58.3%) at the end of follow-up. For the switch group in CD, clinical response (decrease of HBI  $\geq 3$  points) was reached in 13/17 (76.4%) and remission (HBI  $\leq 4$  for CD) in 10/17 (58.8%).

## 6.4.9 Outcomes for dose intensification group

For patients with Crohn's disease, who responded to intensification of anti-TNF $\alpha$  therapy (10/46), there was a significant reduction in mean HBIs from 13.6 to 5.5, (p value = 0.005 95% C.I -19.4 to -7.6), compared to an increase from 18 to 19 for non-responders (**Table 6.5**).

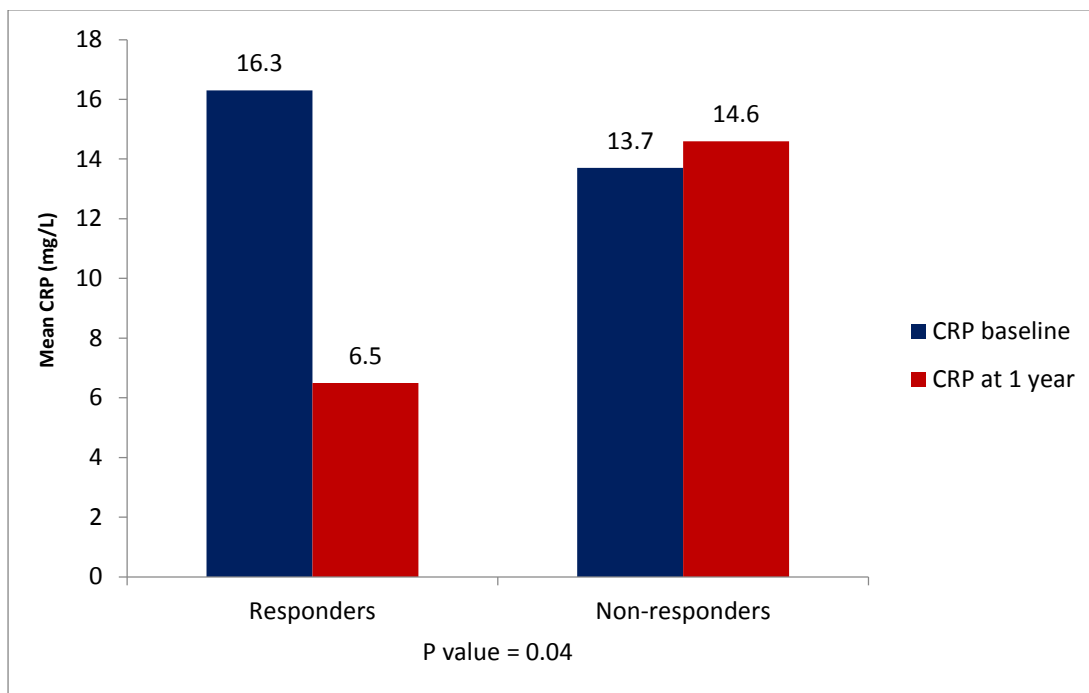
**Table 6.5: Comparison of clinical, biochemical, endoscopic, TDM data for responders/non-responders to anti-TNF $\alpha$  dose escalation**

<i>Anti-TNF<math>\alpha</math> Dose intensification</i>	<i>Responders</i>	<i>Non-responders</i>	<i>P value</i>
N	10 (83.3%)	2 (16.7%)	
Mean CRP Baseline (mg/L)	13.7	14.6	0.92
<b>Mean CRP 12 months (mg/L)</b>	<b>6.5</b>	<b>16.3</b>	<b>0.04</b>
Mean Albumin Baseline (g/L)	39.5	42.5	0.29
Mean Albumin 12 months (g/L)	40.1	40	0.55
HBI baseline	13.6	18	0.24

<i>Anti-TNFa Dose intensification</i>	<i>Responders</i>	<i>Non-responders</i>	<i>P value</i>
HBI 12 months	<b>5.5</b>	<b>19</b>	<b>0.0005</b>
SES-CD Baseline	10.2	9	0.80
Mean anti-TNFa trough (µg/ml)	1.29	0.82	0.74
Anti-TNFa Antibody (n)	0	1 (50%)	0

Additionally there was a significant change in biochemical markers in patients who regained response, post intensification of anti-TNFa therapy, with a reduction in mean CRP from 16.3 mg/L to 6.5 mg/L (p value = 0.04 95% C.I. -18.9 to -0.61), compared to an increase for non-responders, 14.6 mg/L, from 13.7 mg/L (**Figure 6.4**). There were no statistical changes in serum albumin levels. There was a difference in baseline ADL trough levels, in patients who responded to dose intensification, compared to those that didn't. Mean trough for responders to dose intensification was 1.2 µg/ml, compared to a slight difference of 0.82 µg/ml, for those that didn't respond to dose intensification, although this was not statistically significant (p value = 0.60). In addition there was no difference in 1 year outcomes based on initial anti-TNFa antibody levels. Numbers for infliximab were too small to draw any statistical conclusions.

**Figure 6.4: Change in mean CRP in patients post anti-TNF $\alpha$  dose intensification, responders v non-responders (secondary LOR cohort)**



### **6.4.10 Outcomes for switch group**

Analysing the 17 patients, who underwent a switch in their anti-TNF $\alpha$  therapy, as mentioned 12/17 (70.6%) were switched to alternative anti-TNF agents, and 5/17 (29.4%) were switched to non-anti-TNF $\alpha$  agents, namely ustekinumab (vedolizumab was not available at our centre, during the study period) (**Table 6.6**).

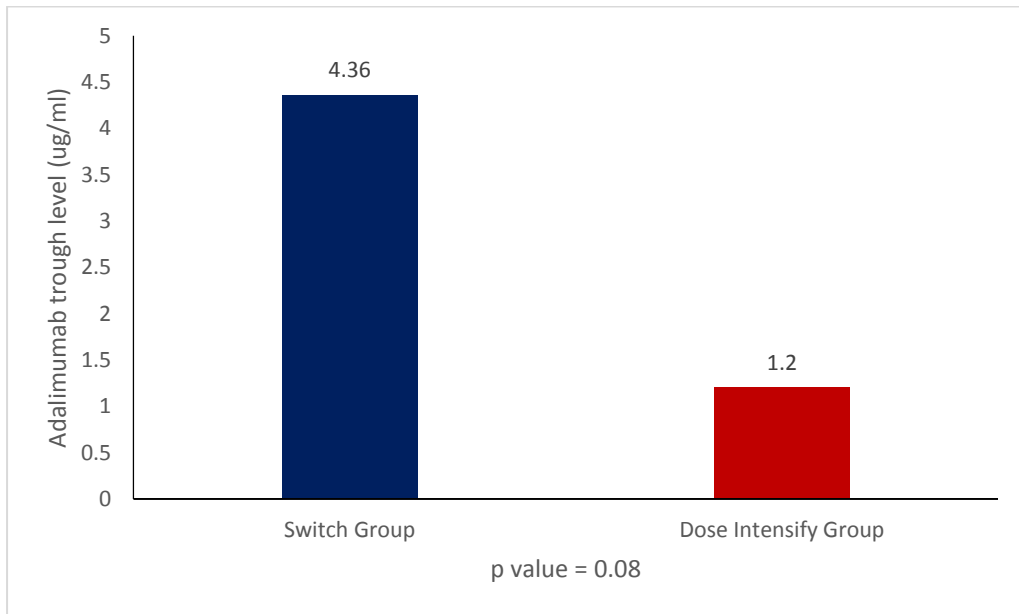
**Table 6.6: Clinical, biochemical, endoscopic, TDM data for patients who had a switch in therapy**

	<i>Switch Group</i>
N	17
Crohn's	15 (88.2%)
Mean CRP Baseline (mg/L)	14.4
Mean CRP 12 months (mg/L)	11.9
Mean Albumin Baseline (g/L)	39.6
Mean Albumin 12 months (g/L)	39.8
HBI baseline	14
HBI 12 months	7.6
SES-CD Baseline	10.4
Anti-TNFa trough( $\mu$ g/ml)	4.4
Anti-TNFa Antibody	7/17 (41.2%)

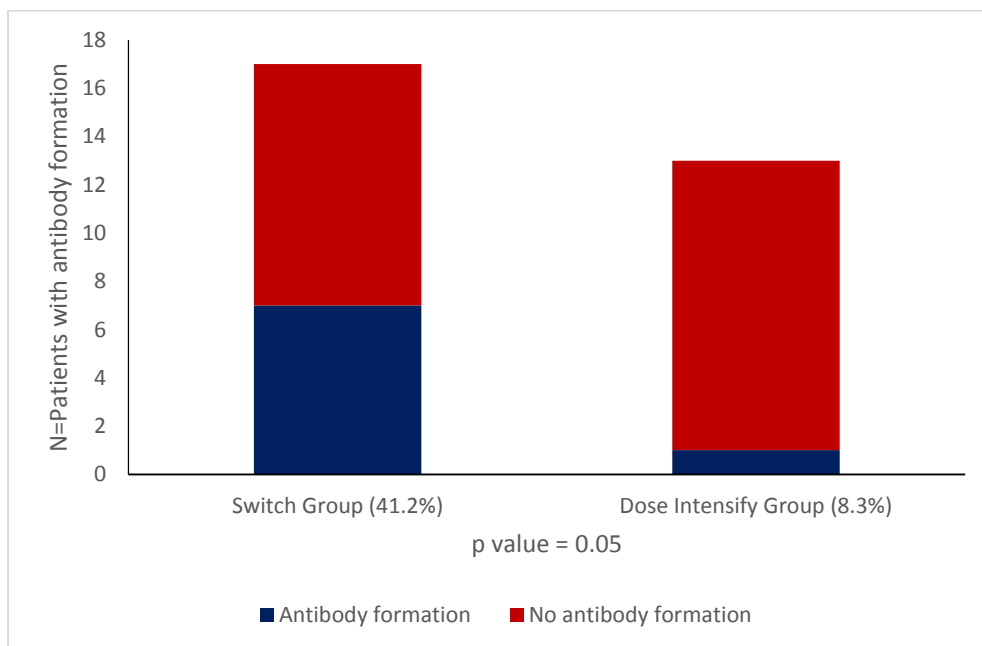
In comparison to the group, who had doses intensified, the switch group, had higher baseline ADL trough levels, 4.36  $\mu$ g/ml for switch group, versus 1.2  $\mu$ g/ml for dose intensify group (p value =0.08 95% C.I. -0.43 to 6.59) (**Figure 6.5**). In addition there were significantly higher rates of antibody formation for the switch group, 7/17 (41.2%) versus 1/12 (8.3%) for the dose intensify group (p value =0.05 95% C.I -0.01 to 0.66 O.R. 0.13) (**Figure 6.6**). For patients who had their anti-TNFa therapy switched,

clinical response (decrease of HBI  $\geq 3$  points for CD) was reached in 66.7% of patients and remission (HBI  $\leq 4$  for CD) in 46.7% at the end of follow-up.

**Figure 6.5: Comparison of Adalimumab trough levels, between Switch and Dose Intensify Groups**



**Figure 6.6: Comparison of antibody formation between Switch and Dose intensify groups (Adalimumab)**



## 6.5 Discussion

Despite the well-established role for anti-TNF $\alpha$  therapy in inducing and maintaining remission, LOR is a common clinical problem, and possess significant dilemmas and problems for clinicians. A recent meta-analysis has shown that up to one-third of anti-TNF $\alpha$  primary responders in Crohn's disease will experience a LOR, and require dose intensification of their anti-TNF $\alpha$  therapy [181]. The burden of secondary LOR is significant, 17.4% of our cohort, who experienced a secondary LOR, required surgical intervention.

As mentioned a number of different strategies are available to help regain clinical response, which can involve dose intensification or switch to other anti-TNF $\alpha$  or other non-anti-TNF $\alpha$  based therapies. A French study looking at dose intensification of infliximab confirms this. In a cohort of 157 UC patients, with secondary LOR, infliximab dose doubling led to short- and long-term event-free survival, in greater than 50% of the cases. The benefits of such a strategy were significantly improved by adding a concomitant immunomodulator [182].

The advent of TDM has helped clinicians identify an immune basis behind LOR, and help regain clinical response by adjusting doses, in a clinically guided fashion [114,116]. From our study there is a suggestion that adjusting doses, based on TDM, can help patients regain clinical response. Overall 75% of patients with secondary LOR, who underwent dose intensification, had a clinical response at one year, with a remission rate of 58.3%. This group of patients had low anti-TNF $\alpha$  trough levels, with a mean trough level of 1.2  $\mu\text{g/ml}$ . It is likely that patients with low trough levels will respond best to dose intensification. Our study didn't identify any impact of antibody formation on response rates, although the numbers were too small, to draw

concrete conclusions. We were unable to assess whether intervention resulted in improvement in anti-TNFa trough levels, due to difficulties accessing anti-TNFa trough assays, as well as unresolved issues around optimal trough levels.

TDM can also help clinicians when deciding whether a switch in treatment is more beneficial for patients, as opposed to dose intensification. Our study showed that for patients, with adequate trough levels, and antibody formation they responded best to having their treatment switched to an alternative agent. Some authors propose making distinctions between UC and CD when making decisions around switch in therapy. The evidence for switching patients treated with infliximab who lose response to adalimumab is weak, with response rates lower overall in comparison to adalimumab switchers. The GAIN trial showed that only twenty-one percent of infliximab patients, switched to adalimumab entered into remission [183]. A meta-analysis by Gisbert et al, showed the addition of a second anti-TNFa agent after the failure of IFX in CD, induced remission in 43% and response in 63% of patients [184]. All UC studies switched IFX to ADL, six of them reporting remission rates ranging from 0% to 50%. The presence of ADA, may suggest a switch outside the anti-TNFa class to treat verified IBD inflammation is a better option, but there is evidence that some patients might still respond to switching to another anti-TNFa agent, possibly because not all anti-TNF agents are mechanistically identical [185]. It's worth noting also from a Danish study, that switchers with anti-IFX antibodies to other agents, within anti-TNFa class, are prone to develop de novo anti-ADL antibodies, which may result in therapeutic failure [127]. The authors propose assessment of ADL immunogenicity in anti-IFX antibody positive switchers to ensure optimal interventions at inadequate treatment responses and to avoid inappropriate ADL intensification regimens. Therefore for patients, with optimal anti-TNFa trough levels, and antibody formation,



there is a strong argument for switching within or outside anti-TNF $\alpha$  class, to help regain clinical response. Further work is required to tease these details out, though its likely patients, with low trough levels, and ADA would benefit, from a ‘switch’ within anti-TNF $\alpha$  class, and those with adequate troughs, and ADA would be best suited to a ‘change’ to an agent, that targets, an alternative pathway, like vedolizumab or ustekinumab [186].

When evaluating a patient with secondary LOR, it’s important to consider a number of factors involved. As mentioned previously it’s important to exclude other cases, for breakthrough symptoms, like irritable bowel syndrome, as well as drivers of non-IBD related inflammation, like infection. As seen from our study, 28% of patients, evaluated for secondary LOR to anti-TNF $\alpha$  therapy, did not require a change in their treatment at one year follow-up. This group had lower clinical, endoscopic and biochemical markers of inflammation at the time of evaluation. Therefore it’s vital that patients are investigated appropriately when being evaluated for possible secondary LOR to anti-TNF $\alpha$  therapy, to ensure that LOR is associated with IBD related inflammation and disease activity.

There is mounting evidence for the incorporation of TDM into the routine monitoring and management of IBD patients on anti-TNF $\alpha$  therapy. A recent systemic review by Ding et al looked at the role for clinical algorithms utilising therapeutic drug monitoring [60]. It’s clear that there is increasing evidence that earlier introduction of anti-TNF $\alpha$  therapy, quite often in combination with an immunomodulator leads to a reduced risk of both primary and secondary LOR. A more aggressive approach earlier on in the disease course, when the inflammatory component is most active, will likely yield better outcomes, particularly for patients with Crohn’s disease. The combination

of LOR assessment and TDM is likely to help improve outcomes, and should be incorporated into everyday practice.

Our study confirms the impact that secondary LOR to anti-TNF $\alpha$  therapy has on patients. TDM was utilised to explore an immune basis behind secondary LOR, and patient's treatment was tailored accordingly. Our study confirms the potential for TDM to help overcome secondary LOR. Our study was limited by sample size, and this may impact on the ability to generalize and interpret results. In addition, our study didn't randomise to a TDM intervention group versus standard of care, due to inadequate power of the sample size. Other barriers to randomisation included the suboptimal response rates in this difficult to treat cohort, as well as the use of prior anti-TNF $\alpha$ , all making it hard not to justify using TDM. Never the less despite the lack of randomisation, our study suggests a benefit for tailoring therapy based on TDM, in cases of secondary LOR. The number of patients treated with infliximab in our cohort was very small, making interpretation difficult. Larger studies are required to further explore the potential of this approach.

This and other studies are helpful in reaffirming the role for TDM in general, and the need for further utilisation of this strategy into everyday clinical practice. Going forward, further larger trials are required, to confirm this viewpoint, as well as the need for quick and time efficient anti-TNF $\alpha$  trough and antibody bedside assays.

## **6.6 Conclusions**

Secondary LOR is associated with a significant burden on patients with IBD. It is a barrier to long-term remission, and the aim of achieving mucosal healing.

Exploring an immune basis behind LOR with TDM is an increasingly important facet to the overall management of IBD. Finally utilising TDM with dose intensification, introduction of immunomodulators or a switch in therapy helps overcome LOR, in a patient focused clinically guided fashion.

# CHAPTER 7- General Discussion

## 7.1 General Overview

Anti-TNF $\alpha$  and immunomodulator therapy have greatly improved outcomes for patients with IBD. Their use has led to improved quality of life, reduced hospitalisations, reduced surgical intervention, as well as reduced steroid dependency. A recent meta-analysis has shown that in CD, anti-TNF $\alpha$  therapy significantly reduced hospitalisation [Odds ratio (OR) 0.46, 95% confidence interval (CI) 0.36-0.60] and surgery (OR 0.23, 95% CI 0.13-0.42) compared to placebo [187]. Similarly for UC, anti-TNF $\alpha$  therapy significantly reduced hospitalisation (OR 0.48, 95% CI 0.29-0.80) and surgery (OR 0.67, 95% CI 0.46-0.97). There is also ample evidence of increased use of anti-TNF $\alpha$  and immunomodulator therapies, as part of the management of IBD. A Canadian study has shown that the use of anti-TNF $\alpha$  agents increased from 2001 through 2014, with a concomitant significant decrease in cumulative use of corticosteroids before anti-TNF $\alpha$  therapy for patients with UC [188]. However, they also found there has been no reduction in cumulative use of corticosteroids before anti-TNF $\alpha$  therapy for patients with CD and no change in use of immunomodulators by patients with CD. These findings indicate a continuing need for optimization of anti-TNF $\alpha$  therapy for patients with IBD.

Despite improvements, loss of response continues to be a cause for concern, and is a significant drawback to anti-TNF $\alpha$  therapy. Therefore, this thesis aimed to explore the impact of LOR on a cohort of IBD patients and to identify any predictors of LOR. From our retrospective cohort study, looking at predictors of LOR, our overall response rate one year after commencing anti-TNF $\alpha$  therapy was 57.5%. Response rates were greater overall for patients treated with infliximab versus adalimumab (65.6% v 52.5 %,

p value =0.05) at the end of one year. Thus despite the great strides being made in improving response rates, there is still a large subset of patients that are experiencing suboptimal or loss of response. Therefore there is a strong need to identify clinical or biochemical factors that help predict loss of response, and to help identify patients that are more likely to experience treatment failure.

As discussed, LOR to anti-TNF $\alpha$  therapy can be multifactorial, but there is increasing awareness of the role of immunogenicity in this process. Antibody formation against anti-TNF $\alpha$  therapy, as was discussed previously, leads to increased drug clearance, and a reduction in circulating drug, leading to lower trough levels, and ultimately primary or secondary LOR. Therapeutic drug monitoring is being increasingly used to explore this immune basis behind LOR, and to develop strategies to help overcome this problem [189]. Therefore we aimed to explore whether TDM could help predict primary and secondary LOR. We also aimed to explore whether adjusting patients treatment based on the information provided by TDM, could help improve response rates.

The following sections, will discuss key findings and achievements, from this research project:

## **7.2 Predictors loss of response**

### **7.2.1 Clinical predictors**

From our retrospective cohort study combination therapy was protective in terms of avoiding LOR, with 45/102 (44.1%) of anti-TNF $\alpha$  responders, receiving combination therapy versus 17/58 (29.3%) for non-responders (p value = 0.001 95% C.I. 0.35 to 0.62 O.R. 1.9). Our findings are consistent with similar data, confirming the

benefits of combination therapy [22]. A recent prospective study has shown that for CD patients, combination therapy was most effective in reducing complications, in patients with stricturing or penetrating disease, and those with duration of disease of less than 5 years [190]. This suggests that patient selection is key, when making decisions about patient's individual treatment

As discussed previously prior anti-TNF $\alpha$  therapy is associated with increased rates of LOR, and our study hints at this. For the pooled data 12/58 (20.7%) of anti-TNF $\alpha$  non responders, were previously exposed to another anti-TNF $\alpha$  agent, versus 13/102 (12.7%) for responders (p value = 0.10 95% C.I. -0.02 to 0.04 O.R. 0.42). This is again important when discussing treatment options with patients. Our study also confirmed the negative impact of smoking on response rates.

## **7.2.2 Biochemical predictors**

Biochemical markers are also useful predictors of LOR [191]. For our cohort study, week 90/102 (88.2%) of anti-TNF $\alpha$  responders, had a week 14 CRP <5 mg/L, versus 28/58 (48.3%) for non-responders (p value 0.001 95% C.I. 0.27 to 0.53 O.R. 8.04). Thus achieving a week 14 CRP of less than 5 mg/L strongly increases the likelihood of satisfactory response.

## **7.2.3 Smoking**

Smoking was significantly associated with LOR. 12/58 (20.7%) of anti-TNF $\alpha$  non-responders smoked versus 10/102 (9.5%) of responders (p value = 0.05 95% C.I. -0.0 to 0.22 O.R. 2.4). Our study also should a stronger association between smoking, Crohn's disease and LOR, compared to UC. All adalimumab non-responders, who smoked, had underlying CD. A multicentre prospective cohort study of 573 CD

patients, has showed that in comparison to non-smokers, continued smokers relapsed more frequently, with an incidence rate of 1.53 (95% C.I. 1.10 -2.17) [192]. In addition non-smoking is associated with a more durable and sustained response to infliximab in patients with CD [193].

## **7.2.4 Ileo-colonic disease phenotype**

There was a trend towards LOR for patients with ileo-colonic disease, 26/37 (70.3%) of adalimumab patients with loss of response, had ileo-colonic disease, compared to 26/43 (60.5%) of adalimumab patients who responded at the end of induction therapy (p value = 0.18).

## **7.2.5 Clinical Impact**

The key clinical impact based on our results, is that it may help identify at risk patients and if increasing CRP and falling albumin consider TDM to help optimise disease management in a patient focused approach.

# **7.3 TDM stand-alone/random assessments**

## **7.3.1 General Overview**

There has been some debate, about the optimal time to use TDM. So firstly we looked at using TDM, in a stand-alone fashion on a cohort of patients on established anti-TNFa therapy. This was a heterogeneous group of patients, who were either well, in remission, or experiencing a flare of their disease. Again 27% (20/74) of patients had a poor outcome, illustrating the impact of LOR to anti-TNFa therapy.

### **7.3.2 Lack of correlation between random TDM and LOR**

This study also showed there was no difference in mean trough levels according to outcome (4.9 µg/ml poor outcome versus 5.4 µg/ml good outcomes, p value = 0.14). Thus when used in a stand-alone fashion, measuring anti-TNFα trough and antibody levels may not be useful.

### **7.3.3 Relationship between trough levels, response rates, and biochemical markers**

Our study did however show that low trough levels do correlate well with elevated CRP, hypoalbuminaemia, and poor response rates, mean CRP 6.66 mg/L (n = 3), mean albumin 37 g/L for patients with low trough levels and poor response versus CRP 2.0 mg/L (n = 24), mean albumin 43 g/L for patients with high trough levels and good response (P = 0.009, 95% confidence interval, -0.78 to -0.12). As mentioned NICE guidelines do not currently recommend extension of TDM beyond centres where it's currently in routine use, due to concerns about reproducibility of tests, cost-effectiveness and clinical evidence in comparison to CRP biomarker [161]. However TDM is an evolving field that offers real potential, acting not only as a marker of disease activity, but also offering the opportunity, to explore an immune basis behind LOR [76, 92]. In addition TDM may help facilitate physicians in complex decision making, such as whether to switch agents, within or outside anti-TNFα class. Finally as discussed harbouring TDM may prove to be a more cost-effective approach, compared to adjusting doses, in the standard fashion [103].

Going forward, it is likely that TDM, and biomarkers like CRP and faecal calprotectin will complement each other [66]. A French study has shown that in IFX-



treated patients with CD in clinical remission, a combination of TLI ( $<2 \mu\text{g/mL}$ ) and faecal calprotectin ( $>250 \mu\text{g/g}$  of stools) is a good model for predicting loss of response [194].

### **7.3.4 Clinical impact**

Lack of numbers achieving ideal/ target trough levels is a key finding of this work, and suggest possible under dosing of anti-TNF $\alpha$  as an explanation for LOR. This requires further study. Based on these results, the next arm of this thesis aimed to investigate the role of TDM, at other key time points in the management of IBD, such as the end of induction therapy, as during an episode of secondary LOR.

## **7.4 Induction phase TDM and primary response**

### **7.4.1 Response at end of induction phase**

For our prospective study, overall response rate at the end of induction therapy for our cohort was 51.4% (n=18) There was a statistically greater response rate in patients treated with infliximab, compared to adalimumab, 70.6% (n=12), compared to 33.3 % (n=6) p value = 0.03 95% C.I. 0.04 to 0.70 O.R. 0.16.

### **7.4.2 Relationship between anti-TNF $\alpha$ trough levels, and response**

Looking at the role of TDM, at the end of induction therapy, there was a clear link between higher anti-TNF $\alpha$  trough levels at the end of induction with clinical response rates. For infliximab, mean trough levels in responders were  $16.4 \mu\text{g/ml}$  (IQR 8.4-22.7)

versus 5.3 µg/ml (0.5-8.8) for non-responders (p value = 0.026 95% CI: 1.50-20.7).

Similarly there was a link between higher ADL levels and clinical response, though not statistically significant. Thus higher trough levels, help predict response to anti-TNF $\alpha$  therapy, and are associated with improved outcomes.

### **7.4.3 Optimal cut-off trough levels for infliximab and adalimumab**

Furthermore an IFX trough level of 4.8 µg/ml predicted clinical response at end of induction, with a sensitivity of 90.91% and a specificity of 67%. Similarly for ADL a trough level of 3.5 µg/ml helped predict clinical response at end of induction, with a sensitivity of 85.7% and a specificity of 81.8%. This links in with work by Ungar et al, who propose that serum levels of 6-10 µg/ml for infliximab and 8-12 µg/ml for adalimumab are required to achieve mucosal healing in 80%-90% of patients with IBD [116]. Optimal targets though still require further clarification and analysis.

### **7.4.4 Benefits of combination therapy**

Our study confirmed the benefits of combination therapy in the management of IBD. The combination of anti-TNF $\alpha$  therapy with immunomodulators is associated with improved anti-TNF $\alpha$  trough levels, particularly for infliximab, as well as a suggestion of reduced antibody formation. For infliximab mean anti-TNF $\alpha$  trough level for patients treated with combination therapy, was 19.6 µg/ml versus 7.5 µg/ml for patients treated without combination therapy (p value = 0.01, 95% C.I: 3.3 to 20.9). No relationship however was established with adalimumab. These results are similar to other studies that re-affirm the benefits of dual combination therapy [107,195-196]. Finally our study also confirmed improved response rates in patients treated with combination therapy.

## **7.4.5 Link between week 14 CRP and induction anti-TNFa trough levels**

In addition, a higher percentage of responders, achieved a week 14 CRP of less than 5 mg/L. This confirms the link between clinical response, anti-TNFa trough levels, and response to CRP [66].

## **7.4.6 Anti-TNFa dose intensification post induction**

For patients who had suboptimal response, anti-TNFa dose intensification helped improve outcomes. For patients (n=16) who had doses adjusted, clinical response (decrease of HBI  $\geq 3$  points for CD) was reached in 11/16 patients (68.8%) patients and remission (HBI  $\leq 4$  for CD) in 10/16 (62.3%) at the end of follow-up. Our study didn't identify a difference in trough levels, between those who responded, and didn't respond to dose intensification, but there was a suggestion, of treatment failure, in patients who developed ADA. 2/5 (40%) of non-responders to anti-TNFa dose intensification had ADA compared to 1/11 (9.1%) for responders, though not statistically significant (p value = 0.16). This links in with the idea that ADA is associated with treatment failure, particularly where patients, have adequate anti-TNFa trough levels.

## **7.5 'Targeted' TDM at time of secondary LOR**

### **7.5.1 General Overview**

As mentioned there is evidence that TDM can be useful in assessing and managing secondary LOR to anti-TNFa therapy [126]. Therefore we aimed to explore the role of TDM in this setting.

## **7.5.2 Sub-therapeutic trough levels, and secondary LOR**

Mean adalimumab trough level was 4.5 µg/ml (IQR 0.44-7.5µg/ml), and 15/36 (42.9%) had a sub-therapeutic trough level less than 1 µg/ml and 9 patients (25.7%) had antibodies to adalimumab. Mean infliximab trough level was 8.1 µg/ml (IQR 1.9-14.5 µg/ml) and 2/10 (20%) had sub-therapeutic trough levels. There was no evidence of antibodies against infliximab in our cohort. Sub-therapeutic trough levels are strongly associated with active disease, leading to disease progression and further complications [113].

## **7.5.3 Trough levels, and one year outcomes**

For our prospective cohort, higher baseline adalimumab trough levels, were noted in patients who were well, at one year follow-up compared to patients, who were unwell, and required change in therapy, mean trough 6.4 µg/ml (IQR 2.1-10.3) compared to 2.9 µg/ml (IQR 0.3-6.3) (p value = 0.0265 95% C.I. 0.4 to 6.5). Thus again it's clear, that low trough levels, are associated with LOR, and lead to poorer outcomes. Similarly for infliximab higher baseline trough levels, were noted in patients who were well at one year follow-up compared to those who required change in treatment, 16.0 µg/ml (IQR 15-16.8) versus 4.6 µg/ml (IQR 1.1-6.1), (p value = 0.005 95% CI 4.5 to 18.3).

## **7.5.4 Low 'targeted' trough levels, in sustained LOR, with**

### **high CRP**

Patients treated with adalimumab who required a change in treatment (unwell group) were less likely to have evidence of biochemical remission, with only 11/26 (42.3%) having CRP <5 mg/L at time of assessment, compared to 9/10 (90%) for the

well group (p value = 0.0089 95% C.I -0.83 to 0.13, OR 0.08). Mean CRP for unwell group was 11.5 mg/L, compared to 4.7 mg/L, for the well group (p value = 0.11). Similar results were noted for infliximab, with high CRP and lower trough levels in patients with sustained secondary LOR. Our results emphasise the importance of biochemical markers in predicting evolving and sustained LOR.

### **7.5.5 TDM, dose intensification and switch in therapy**

Our study also confirmed the usefulness of TDM, when considering a change in therapy at the time of secondary LOR. Overall the addition of TDM, to a clinical based strategy resulted in a response rate of 75%. In comparison to the group who had doses intensified, the switch group had higher baseline trough levels, 4.36 µg/ml for switch group, versus 1.2 µg/ml for dose intensify group (p value =0.08 95% C.I. -0.43 to 6.59). In addition there were significantly higher rates of antibody formation for the switch group, 7/17 (41.2%) versus 1/12 (8.3%) for the dose intensify group (p value =0.05 95% C.I -0.01 to 0.66 O.R. 0.13). Thus for patients, with low trough levels, without antibody formation, it's reasonable to dose intensify, however, in the setting of adequate trough levels, and antibody formation, then a switch in treatment is likely a better strategy.

As mentioned previously, there is ongoing work looking at the distinction between clinically significant and insignificant ADA. Recent post hoc analysis of the TAXIT study explored this [197]. The authors found that upon dose intensification, low concentration ADAs, not detectable using a drug-sensitive assay, disappear in more than half of the patients over time and are clinically non-relevant. In contrast, high concentration ADAs which are typically also detected in a drug-sensitive assay, persist over time and necessitate a higher cumulative dose and drug cost. Therefore for patients

with persistent high levels of ADA, and adequate trough levels, proactive drug switching may be more cost-efficient.

## **7.6 Variations in immunogenicity and TDM between infliximab and adalimumab**

Reviewing our data, there is a strong suggestion of suboptimal response rates, for patients treated with adalimumab, in comparison to infliximab. Our results are similar to other centres, where this trend has been confirmed [198-199]. There is also evidence that patients treated with infliximab, have less steroid usage, in comparison to adalimumab [200]. One of the key findings from our work is that despite our infliximab cohort, having a more aggressive phenotype, a more severe inflammatory burden, and higher rates of prior anti-TNF $\alpha$  exposure, there was a significant difference in response rates, in comparison to the adalimumab cohort. Possible explanations for this disparity could include greater ADA formation, a more aggressive phenotype, such as ileo-colonic disease, as well as the deleterious effects of smoking, in comparison to the UC. Our results, do hint at differences in immunogenicity between the two agents, with a lack of correlation of adalimumab trough levels, with CRP and albumin, compared to infliximab. Possible factors may include: higher ADA rates, fewer patients reaching or achieving optimal or target trough levels. Possible barriers to achieving these targets could include compliance issues, and patient selection. Also for our cohort, the addition of azathioprine was not associated in an improvement in adalimumab trough levels, in comparison to infliximab, suggesting ADA may not be the driving force entirely and other mechanisms may impact on the improvement in

infliximab trough levels. Finally assessment times for subcutaneous agents, at induction may prove to be too soon.

## **7.7 Future Directions**

Going forward, there is a need for greater availability for affordable, near-patient anti-TNF $\alpha$  trough and antibody assays that allow the smooth incorporation of therapeutic drug monitoring into everyday clinical practice.

As mentioned there is increasing evidence that combination therapy, reduces antibody formation, and can help improve trough levels. This strategy has been increasingly shown to be associated with improved response rates and greater likelihood of mucosal healing [201]. The potential of 6-TGN assays has yet to be achieved, and further work is required to encourage greater usage. The role of immunomodulators in optimising anti-TNF $\alpha$  therapies needs further study, particularly for adalimumab.

In addition there is a need for a large prospective randomised multi-centre trial to assess the efficacy of induction and LOR targeted TDM strategies to tailor patient care, with the aim of achieving optimal trough levels. Finally it would be desirable to develop selective TDM strategies in high risk patient cohorts.

## CHAPTER 8- Conclusions and future work

This dissertation concludes that anti-TNF $\alpha$  therapy in combination with immunomodulator therapy has greatly helped to improve outcomes in patients with IBD. Loss of response though is an increasing concern impacting on its success. We have accurately identified a number of predictors of LOR, such as smoking, prior anti-TNF $\alpha$  use, and the protective benefits of combination therapy. In addition the role of biochemical markers like CRP is reaffirmed. This information is critically important when deciding upon an individual's treatment strategy.

The immune basis behind LOR has also been explored, and the potential role for therapeutic drug monitoring also investigated. We have demonstrated that TDM is not useful, when used in a stand-alone fashion, and is best utilised during/at the end of induction therapy, or when exploring an immune basis, behind secondary LOR. Our results show the link between clinical response at the end of induction therapy, with anti-TNF $\alpha$  trough and antibody levels. Patients with higher anti-TNF $\alpha$  trough levels are more likely to derive a clinical response, and be maintained in remission. Furthermore our results confirm that combination therapy is associated with improved anti-TNF $\alpha$  trough levels, and response rates.

In addition our results show the benefit of using TDM, in the setting of secondary LOR. We have proven that dose intensification, works best, when an individual has low trough levels, without antibody formation, and that a switch in therapy or addition of an immunomodulator may be required, where an individual has adequate or low trough levels, with antibody formation.



Further work is required to confirm the clinical application of TDM. There is a need to explore the complex nature of anti-TNF $\alpha$  antibody formation. Not all antibodies are clinically relevant, and this needs to be explored in further detail. Optimal targets need to be defined, taking into account different disease phenotype. The treat to target approach appears attractive, but large randomized, clinical trials are required to confirm its everyday clinical usefulness. In addition, the temporal nature of immunogenicity is not fully understood, and this too requires further analysis. Going forward, it is likely therapeutic drug monitoring, will be increasingly incorporated into routine clinical practice, hopefully with improved patient outcomes, as we move towards, a more patient focused approach, taking into account underlying drug and patient pharmacokinetics and pharmacogenomics respectively. There is real potential in the field to reduce complications, and help alter the natural history of inflammatory bowel disease.

## REFERENCES

1. Satsangi J, Jewell DP, Bell JI. The genetics of inflammatory bowel disease. *Gut*. 1997; 40:572.
2. Jostins L, Ripke S, Weersma RK, et al. Host-microbe interactions have shaped the genetic architecture of inflammatory bowel disease. *Nature*. 2012 Nov 1;491(7422):119-24
3. Loftus EV Jr. Clinical epidemiology of inflammatory bowel disease: Incidence, prevalence, and environmental influences. *Gastroenterology*. 2004 May;126(6):1504-17.
4. Virta LJ, Saarinen MM, Kolho KL. Inflammatory Bowel Disease Incidence is on the Continuous Rise Among All Paediatric Patients Except for the Very Young: A Nationwide Registry-based Study on 28-Year Follow-up. *J Crohns Colitis*. 2017 Feb;11(2):150-156. Epub 2016 Aug 23.
5. Coughlan A, Wylde R, Lafferty L, et al. DOCHAS Study. A rising incidence and poorer male outcomes characterise early onset paediatric inflammatory bowel disease. *Aliment Pharmacol Ther*. 2017 Jun;45(12):1534-1541. [Epub ahead of print]
6. Huang Z, Peng K, Li X et al. Mutations in Interleukin-10 Receptor and Clinical Phenotypes in Patients with Very Early Onset Inflammatory Bowel Disease: A Chinese VEO-IBD Collaboration Group Survey. *Inflamm Bowel Dis*. 2017 Apr;23(4):578-590.
7. Sands BE. From symptom to diagnosis: clinical distinctions among various forms of intestinal inflammation. *Gastroenterology*. 2004 May;126(6):1518-32.

8. Lawrance IC, Rogler G, Bamias G et al. Cellular and Molecular Mediators of Intestinal Fibrosis. *J Crohns Colitis*. 2015 Nov 2. pii: j.crohns.2014.09.008.
9. Morson BC. Pathology of Crohn's Disease. *Ann R Coll Surg Engl*. 1990; 72(3):150-1
10. Mowat C, Cole A, Windsor A, et al. Guidelines for the management of inflammatory bowel disease in adults. *Gut* 2011;60:571–607.
11. Friedman LS, Richter JM, Kirkham SE, et al. 5-Aminosalicylic acid enemas in refractory distal ulcerative colitis: a randomized, controlled trial. *Am J Gastroenterol*. 1986 Jun;81(6):412-8
12. Cominelli F, Zipser RD, Dinarello CA. Sulfasalazine inhibits cytokine production in human mononuclear cells: A novel anti-inflammatory mechanism. *Gastroenterology* 1992; 96:A96.
13. Benchimol EI, Seow CH, Steinhart AH, et al. Traditional corticosteroids for induction of remission in Crohn's disease. *Cochrane Database Syst Rev*. 2008 Apr 16;(2):CD006792.
14. Candy S, Wright J, Gerber M, et al. A controlled double blind study of azathioprine in the management of Crohn's disease. *Gut* 1995; 37 (5):674-8.
15. Fraser AG, Orchard TR, Jewell DP. The efficacy of azathioprine for the treatment of inflammatory bowel disease: a 30 year review. *Gut*. 2002 Apr;50(4):485-9.
16. Chande N, Tsoulis DJ, MacDonald JK. Azathioprine or 6-mercaptopurine for induction of remission in Crohn's disease. *Cochrane Database Syst Rev* 2013; 4:CD000545.
17. Thomas CW, Myhre GM, Tschumper R, et al. Selective inhibition of inflammatory gene expression in activated T lymphocytes: a mechanism of

- immune suppression by thiopurines. *J Pharmacol Exp Ther.* 2005 Feb;312(2):537-45.
18. Markowitz J, Grancher K, Kohn N, et al. A multicenter trial of 6-mercaptopurine and prednisone in children with newly diagnosed Crohn's disease. *Gastroenterology* 2000; 119(4):895-902.
  19. Prefontaine E, Macdonald JK, Sutherland LR. Azathioprine or 6-mercaptopurine for induction of remission in Crohn's disease. *Cochrane Database Syst Rev* 2009; CD000545.
  20. Peyrin-Biroulet L, Deltenre P, Ardizzone S, et al. Azathioprine and 6-mercaptopurine for the prevention of postoperative recurrence in Crohn's disease: a meta-analysis. *Am J Gastroenterol* 2009; 104(8):2089-96
  21. Mowat C, Arnott I, Cahill A, et al. Mercaptopurine versus placebo to prevent recurrence of Crohn's disease after surgical resection (TOPPIC): a multicentre, double-blind, randomised controlled trial. *Lancet Gastroenterol Hepatol.* 2016 Dec;1(4):273-282
  22. Colombel JF, Sandborn WJ, Reinisch W, et al. Infliximab, azathioprine, or combination therapy for Crohn's disease. *N Engl J Med* 2010 Apr 15;362(15):1383-95.
  23. Axelrad JE, Roy A, Lawlor G, Korelitz B, et al. Thiopurines and inflammatory bowel disease: Current evidence and a historical perspective. *World J Gastroenterol.* 2016 Dec 14;22(46):10103-10117. Review.
  24. Relling MV, Gardner EE, Sandborn WJ, et al. Clinical pharmacogenetics implementation consortium guidelines for thiopurine methyltransferase genotype and thiopurine dosing: 2013 update. *Clin Pharmacol Ther* 2013; 93(4):324-5.

25. Colombel JF, Ferrari N, Debuysere H, et al. Genotypic analysis of thiopurine S-methyltransferase in patients with Crohn's disease and severe myelosuppression during azathioprine therapy. *Gastroenterology* 2000; 118 (6):1025-30.
26. Bergan S, Bentdal O, Sødal G, et al. Patterns of azathioprine metabolites in neutrophils, lymphocytes, reticulocytes, and erythrocytes: relevance to toxicity and monitoring in recipients of renal allografts. *Ther Drug Monit.* 1997 Oct;19(5):502-9.
27. de Graaf P, de Boer NK, Wong DR, et al. Influence of 5-aminosalicylic acid on 6-thioguanosine phosphate metabolite levels: a prospective study in patients under steady thiopurine therapy. *Br J Pharmacol.* 2010 Jul;160(5):1083-91.
28. Stocco G, Cuzzoni E, Favretto D et al. Thiopurine metabolites variations during co-treatment with aminosalicylates for inflammatory bowel disease: effect of N-acetyl transferase polymorphisms. *World J Gastroenterol.* 2015 Mar 28;21(12):3571-8.
29. Lennard L, Gibson BE, Nicole T, Lilleyman JS. Congenital thiopurine methyltransferase deficiency and 6-mercaptopurine toxicity during treatment for acute lymphoblastic leukaemia. *Arch Dis Child* 1993; 69 (5):577-9.
30. Gisbert JP, Niño P, Rodrigo L, et al. Thiopurine methyltransferase (TPMT) activity and adverse effects of azathioprine in inflammatory bowel disease: long-term follow-up study of 394 patients. *Am J Gastroenterol* 2006; 101 (12):2769-76.
31. Lichtenstein GR. Use of laboratory testing to guide 6-mercaptopurine/azathioprine therapy. *Gastroenterology* 2004; 127 (5):1558-64.
32. Sandborn WJ, Tremaine WJ, Wolf DC, et al. Lack of effect of intravenous administration on time to respond to azathioprine for steroid-treated Crohn's

- disease. North American Azathioprine Study Group. *Gastroenterology* 1999; 117 (3):527-35.
33. Coenen MJ, de Jong DJ, van Marrewijk CJ, et al. Identification of Patients With Variants in TPMT and Dose Reduction Reduces Hematologic Events During Thiopurine Treatment of Inflammatory Bowel Disease. *Gastroenterology*. 2015 Oct;149(4):907-17.e7.
34. Dubinsky MC, Lamothe S, Yang HY, et al. Pharmacogenomics and metabolite measurement for 6-mercaptopurine therapy in inflammatory bowel disease. *Gastroenterology*. 2000 Apr;118(4):705-13.
35. Osterman MT, Kundu R, Lichtenstein GR, Lewis JD. Association of 6-thioguanine nucleotide levels and inflammatory bowel disease activity: a meta-analysis. *Gastroenterology*. 2006 Apr;130(4):1047-53
36. Roblin X, Serre-Debeauvais F, Phelip JM, et al. 6-thioguanine monitoring in steroid-dependent patients with inflammatory bowel diseases receiving azathioprine. *Aliment Pharmacol Ther*. 2005 Apr 1;21(7):829-39
37. Poon SS, Asher R, Jackson R, Kneebone A, et al. Body Mass Index and Smoking Affect Thioguanine Nucleotide Levels in Inflammatory Bowel Disease. *J Crohns Colitis*. 2015 Aug;9(8):640-6. .
38. Lennard L, Singleton HJ. High performance liquid chromatographic assay of the methyl and nucleotide metabolites of 6-mercaptopurine: quantitation of red blood cell 6-thioguanine nucleotide, 6-thioinosinic acid and 6-methylmercaptopurine metabolites in a single sample. *J Chromatog* 1992;583 (1):83-90

39. Lowry PW, Franklin CL, Weaver AL, et al. Measurement of thiopurine methyltransferase activity and azathioprine metabolites in patients with inflammatory bowel disease. *Gut* 2001;49 (5):665–70
40. Stocco G, Londero M, Campanozzi A, et al. Usefulness of the measurement of azathioprine metabolites in the assessment of non-adherence. *J Crohns Colitis*. 2010 Nov;4(5):599-602.
41. Decaux G, Prospert F, Horsmans Y et al. Relationship between red cell mean corpuscular volume and 6-thioguanine nucleotides in patients treated with azathioprine. *J Lab Clin Med*. 2000 Mar;135(3):256-62.
42. Diveu C, McGeachy MJ, Cua DJ. Cytokines that regulate autoimmunity. *Curr Opin Immunol* 2008; 20 (6):663-8.
43. Murch SH, Braegger CP, Walker-Smith JA, et al. Location of tumour necrosis factor alpha by immunohistochemistry in chronic inflammatory bowel disease. *Gut*. 1993 Dec;34(12):1705-9.
44. Braegger CP, Nicholls S, Murch SH, et al. Tumour necrosis factor alpha in stool as a marker of intestinal inflammation. *Lancet*. 1992 Jan 11;339(8785):89-91.
45. Costa J, Magro F, Caldeira D, et al. Infliximab reduces hospitalizations and surgery interventions in patients with inflammatory bowel disease: a systematic review and meta-analysis. *Inflamm Bowel Dis*. 2013;19(10):2098–110.
46. Hanauer SB, Sandborn WJ, Rutgeerts P, et al. Human anti-tumor necrosis factor monoclonal antibody (adalimumab) in Crohn's disease: the CLASSIC-I trial. *Gastroenterology*. 2006 Feb;130(2):323-33
47. Reinisch W, Sandborn WJ, Hommes DW, et al. Adalimumab for induction of clinical remission in moderately to severely active ulcerative colitis: results of a randomised controlled trial. *Gut*. 2011 Jun;60(6):780-7.

48. Rutgeerts P, Sandborn WJ, Feagan BG, et al. Infliximab for induction and maintenance therapy for ulcerative colitis. *N Engl J Med*. 2005 Dec 8;353(23):2462-76.
49. Sandborn WJ, van Assche G, Reinisch W, et al. Adalimumab induces and maintains clinical remission in patients with moderate-to-severe ulcerative colitis. *Gastroenterology*. 2012 Feb;142(2):257-65.e1-3.
50. Schellekens H. Factors influencing the immunogenicity of therapeutic proteins. *Nephrol Dial Transplant*. 2005; 20(6):3-9
51. Sandborn WJ, Feagan BG, Marano C, et al.; PURSUIT-SC Study Group. Subcutaneous golimumab induces clinical response and remission in patients with moderate-to-severe ulcerative colitis. *Gastroenterology*. 2014 Jan;146(1):85-95; quiz e14-5.
52. Sandborn WJ, Feagan BG, Marano C, et al. PURSUIT-Maintenance Study Group. Subcutaneous golimumab maintains clinical response in patients with moderate-to-severe ulcerative colitis. *Gastroenterology*. 2014 Jan;146(1):96-109.e1.
53. Schreiber S, Reinisch W, Colombel JF, et al. Subgroup analysis of the placebo-controlled CHARM trial: increased remission rates through 3 years for adalimumab-treated patients with early Crohn's disease. *J Crohns Colitis*. 2013;7(3):213-21.
54. Järnerot G, Hertervig E, Friis-Liby I, et al. Infliximab as rescue therapy in severe to moderately severe ulcerative colitis: a randomized, placebo-controlled study. *Gastroenterology*. 2005 Jun;128(7):1805-11.
55. Gece KB, Bemelman W, Kamm MA, et al. A global consensus on the classification, diagnosis and multidisciplinary treatment of perianal fistulising



Crohn's disease. World Gastroenterology Organization, International Organisation for Inflammatory Bowel Diseases IOIBD, European Society of Coloproctology and Roberts Clinical Trials; World Gastroenterology Organization International Organisation for Inflammatory Bowel Diseases IOIBD European Society of Coloproctology and Roberts Clinical Trials. *Gut*. 2014 Sep;63(9):1381-92.

56. Neurath MF, Travis SP. Mucosal healing in inflammatory bowel diseases: a systematic review. *Gut*. 2012. Nov;61(11):1619-35. Epub 2012 Jul 27. Review.
57. Bryant RV, Burger DC, Delo J, et al. Beyond endoscopic mucosal healing in UC: histological remission better predicts corticosteroid use and hospitalisation over 6 years of follow-up. *Gut*. 2016 Mar;65(3):408-14.
58. Hanauer SB, Feagan BG, Lichtenstein GR, et al. Maintenance infliximab for Crohn's disease: the ACCENT I randomised trial. *Lancet*. 2002;359(9317):1541-9.
59. Lee LY, Sanderson JD, Irving PM. Anti-infliximab antibodies in inflammatory bowel disease: prevalence, infusion reactions, immunosuppression and response, a meta-analysis. *Eur J Gastroenterol Hepatol* 2012. 24 (9): 1078-85.
60. Ding NS, Hart A, De Cruz P. Systematic review: predicting and optimising response to anti-TNF therapy in Crohn's disease - algorithm for practical management. *Aliment Pharmacol Ther*. 2016;43(1):30-51.
61. Siegel CA, Melmed GY. Predicting response to anti-TNF agents for the treatment of crohn's disease. *Therap Adv Gastroenterol*. 2009;2(4):245-251.
62. Ben-Horin S, Chowers Y. Review article: loss of response to anti-TNF treatments in Crohn's disease. *Aliment Pharmacol Ther*. 2011;33(9):987-995.

63. Lichtenstein GR, Olson A, Travers S, et al. Factors associated with the development of intestinal strictures or obstructions in patients with Crohn's disease. *Am J Gastroenterol*. 2006 May;101(5):1030-8.
64. Pariente B, Laharie D. Review article: why, when and how to de-escalate therapy in inflammatory bowel diseases. *Aliment Pharmacol Ther* 2014; 40 (4): 338–53.
65. Vande Casteele N, Gils A. Pharmacokinetics of anti-TNF monoclonal antibodies in inflammatory bowel disease: Adding value to current practice. *J Clin Pharmacol*. 2015 Mar;55 Suppl 3:S39-50.
66. Roblin X, Marotte H, Leclerc M, et al. Combination of C-reactive Protein, Infliximab Trough Levels, and Stable but Not Transient Antibodies to Infliximab Are Associated With Loss of Response to Infliximab in Inflammatory Bowel Disease. *J Crohns Colitis*. 2015 Jul;9(7):525-31
67. Ternant D, Aubourg A, Magdelaine-Beuzelin C, et al. Infliximab pharmacokinetics in inflammatory bowel disease patients. *Ther Drug Monit*. 2008;30(4):523–529.
68. Vande Casteele N, Ferrante M, Van Assche G, et al. Trough concentrations of infliximab guide dosing for patients with inflammatory bowel disease. *Gastroenterology*. 2015 Jun;148(7):1320-9.e3.
69. Brandse JF, Vos LM, Jansen J, Schakel T, et al. Serum concentration of anti-TNF antibodies, adverse effects and quality of life in patients with inflammatory bowel disease in remission on maintenance treatment. *J Crohns Colitis*. 2015 Nov;9(11):973-81.

70. Ungar B, Chowers Y, Yavzori M, et al. The temporal evolution of antidrug antibodies in patients with inflammatory bowel disease treated with infliximab. *Gut* 2014;63(8):1258–64.
71. European Medicines Agency: Inflectra. European public assessment report. [http://www.ema.europa.eu/ema/index.jsp?curl=pages/medicines/human/medicines/002778/human\\_med\\_001677.jsp&mid=WC0b01ac0](http://www.ema.europa.eu/ema/index.jsp?curl=pages/medicines/human/medicines/002778/human_med_001677.jsp&mid=WC0b01ac0)
72. Ben-Horin S, Yavzori M, Benhar I, et al. Cross-immunogenicity: antibodies to infliximab in Remicade-treated patients with IBD similarly recognise the biosimilar Remsima. *Gut*. 2016 Jul;65(7):1132-8.
73. Baert F, Noman M, Vermeire S, et al. Influence of immunogenicity on the long-term efficacy of infliximab in Crohn's disease. *N Engl J Med*. 2003; 348(7):601–608.
74. Ternant D, Mulleman D, Degenne D, et al. An enzyme-linked immunosorbent assay for therapeutic drug monitoring of infliximab. *Ther Drug Monit*. 2006; 28(2):169–174.
75. Buurman DJ, Vande Castele N, Sturkenboom MG, et al. Letter: detection of infliximab levels and anti-infliximab antibodies—comparison of three different assays; authors' reply. *Aliment Pharmacol Ther*. 2013; 37(2):282
76. Imaeda H, Takahashi K, Fujimoto T, et al.. Clinical utility of newly developed immunoassays for serum concentrations of adalimumab and anti-adalimumab antibodies in patients with Crohn's disease. *J Gastroenterol*. 2014 Jan;49(1):100-9.
77. Vande Castele N, Buurman DJ, Sturkenboom MGG, et al. Detection of infliximab levels and anti-infliximab antibodies: a comparison of three different assays. *Aliment Pharmacol Therapeut*. 2012; 36(8):765–771.

78. Gils A, Vande Castele N, Poppe R, et al. Development of a universal anti-adalimumab antibody standard for interlaboratory harmonization. *Ther Drug Monit.* 2014 Oct;36(5):669-73
79. Lu J, Van Stappen T, Spasic D, et al. Fiber optic-SPR platform for fast and sensitive infliximab detection in serum of inflammatory bowel disease patients. *Biosens Bioelectron.* 2016 May 15;79:173-9.
80. Malíčková K, Ďuricová D, Bortlík M, et al. M. Serum trough infliximab levels: A comparison of three different immunoassays for the monitoring of CT-P13 (infliximab) treatment in patients with inflammatory bowel disease. *Biologicals.* 2016;44 (1):33-36.
81. Corstjens PL, Fidder HH, Wiesmeijer KC, et al. A rapid assay for on-site monitoring of infliximab trough levels: a feasibility study. *Anal Bioanal Chem.* 2013;405 (23):7367-7375.
82. Wang SL, Ohrmund L, Hauenstein S, et al. Development and validation of a homogeneous mobility shift assay for the measurement of infliximab and antibodies-to-infliximab levels in patient serum. *J Immunol Methods.* 2012;382(1-2):177-188.
83. Van Stappen T, Billiet T, Vande Castele N, et al. An Optimized Anti-infliximab Bridging Enzyme-linked Immunosorbent Assay for Harmonization of Anti-infliximab Antibody Titers in Patients with Inflammatory Bowel Diseases. *Inflamm Bowel Dis.* 2015;21 (9):2172-2177.
84. Bloem K, van Leeuwen A, Verbeek G, et al. Systematic comparison of drug-tolerant assays for anti-drug antibodies in a cohort of adalimumab-treated rheumatoid arthritis patients. *J Immunol Methods.* 2015;418:29-38.

85. Van Stappen T, Brouwers E, Vermeire S, Gils A. Validation of a sample pretreatment protocol to convert a drug-sensitive into a drug-tolerant anti-infliximab antibody immunoassay. *Drug Test Anal.* 2017 Feb;9(2):243-247.
86. Steenholdt C, Bendtzen K, Brynskov J, Thomsen OØ, Ainsworth MA. Cut-off levels and diagnostic accuracy of infliximab trough levels and anti-infliximab antibodies in Crohn's disease. *Scand J Gastroenterol.* 2011 Mar;46(3):310-8.
87. Ainsworth MA, Bendtzen K, Brynskov J. Tumor necrosis factor-alpha binding capacity and anti-infliximab antibodies measured by fluid-phase radioimmunoassays as predictors of clinical efficacy of infliximab in Crohn's disease. *Am J Gastroenterol.* 2008;103(4):944-948.
88. Yamada A, Sono K, Hosoe N, Takada N, Suzuki Y. Monitoring functional serum antitumor necrosis factor antibody level in Crohn's disease patients who maintained and those who lost response to anti-TNF. *Inflamm Bowel Dis.* 2010;16 (11):1898-1904.
89. Pariente B, Pineton de Chambrun G, et al. Trough levels and antibodies to infliximab may not predict response to intensification of infliximab therapy in patients with inflammatory bowel disease. *Inflamm Bowel Dis.* 2012;18 (7):1199-1206.
90. Karmiris K, Paintaud G, Noman M, et al. Influence of trough serum levels and immunogenicity on long-term outcome of adalimumab therapy in Crohn's disease. *Gastroenterology.* 2009;137 (5):1628-1640.
91. Marits P, Landucci L, Sundin U et al. Trough s-infliximab and antibodies towards infliximab in a cohort of 79 IBD patients with maintenance infliximab treatment. *J Crohns Colitis.* 2014;8 (8):881-889.

92. Bortlik M, Duricova D, Malickova K, et al. Infliximab trough levels may predict sustained response to infliximab in patients with Crohn's disease. *J Crohns Colitis*. 2013;7 (9):736-743.
93. Adedokun OJ, Sandborn WJ, et al. Association between serum concentration of infliximab and efficacy in adult patients with ulcerative colitis. *Gastroenterology*. 2014;147 (6):1296-1307.e5.
94. Cornillie F, Hanauer SB, Diamond RH, et al. Postinduction serum infliximab trough level and decrease of C-reactive protein level are associated with durable sustained response to infliximab: a retrospective analysis of the ACCENT I trial. *Gut*. 2014;63 (11):1721-1727.
95. Reinisch W, Colombel JF, Sandborn WJ, et al. Factors associated with short- and long-term outcomes of therapy for Crohn's disease. *Clin Gastroenterol Hepatol*. 2015;13 (3):539-547.e2.
96. Imaeda H, Bamba S, Takahashi K, et al. Relationship between serum infliximab trough levels and endoscopic activities in patients with Crohn's disease under scheduled maintenance treatment. *J Gastroenterol*. 2014;49 (4) 674-682.
97. Roblin X, Marotte H, Rinaudo M et al. Association between pharmacokinetics of adalimumab and mucosal healing in patients with inflammatory bowel diseases. *Clin Gastroenterol Hepatol*. 2014;12 (1):80-84.e2.
98. Brandse JF, van den Brink GR, Wildenberg ME, et al. Loss of Infliximab Into Feces Is Associated With Lack of Response to Therapy in Patients With Severe Ulcerative Colitis. *Gastroenterology*. 2015 Aug;149(2):350-5.e2
99. Gibson DJ, Heetun ZS, Redmond CE et al. An accelerated infliximab induction regimen reduces the need for early colectomy in patients with acute severe ulcerative colitis. *Clin Gastroenterol Hepatol*. 2015 Feb;13(2):330-335.e1.

100. Yarur AJ, Jain A, Sussman DA, et al. The association of tissue anti-TNF drug levels with serological and endoscopic disease activity in inflammatory bowel disease: the ATLAS study. *Gut*. 2016 Feb;65(2):249-55
101. Warman A, Straathof JW, Derijks LJ. Therapeutic drug monitoring of infliximab in inflammatory bowel disease patients in a teaching hospital setting: results of a prospective cohort study. *Eur J Gastroenterol Hepatol*. 2015 Mar;27(3):242-8.
102. Kobayashi T, Suzuki Y, Motoya S, et al. Gastroenterol. First trough level of infliximab at week 2 predicts future outcomes of induction therapy in ulcerative colitis-results from a multicenter prospective randomized controlled trial and its post hoc analysis. *J Gastroenterol*. 2016 Mar;51(3):241-51.
103. Steenholdt C, Brynskov J, Thomsen OØ, et al. Individualised therapy is more cost-effective than dose intensification in patients with Crohn's disease who lose response to anti-TNF treatment: a randomised, controlled trial. *Gut* 2014;63 (6):919-927.
104. Velayos FS, Kahn JG, Sandborn WJ, et al. A test-based strategy is more cost effective than empiric dose escalation for patients with Crohn's disease who lose responsiveness to infliximab. *Clin Gastroenterol Hepatol*. 2013 Jun;11(6):654-66.
105. Ben-Horin S, Yavzori M, Katz L, et al. The immunogenic part of infliximab is the F(ab')<sub>2</sub>, but measuring antibodies to the intact infliximab molecule is more clinically useful. *Gut*. 2011; 60(1):41-48.

106. O'Meara S, Nanda KS, Moss AC. Antibodies to infliximab and risk of infusion reactions in patients with inflammatory bowel disease: a systematic review and meta-analysis. *Inflamm Bowel Dis.* 2014; 20(1):1–6.
107. Panaccione R, Ghosh S, Middleton S et al. Combination therapy with infliximab and azathioprine is superior to monotherapy with either agent in ulcerative colitis. *Gastroenterology* 2014;146:392–400.e3.
108. van Schaik T, Maljaars JP, Roopram RK et al. Influence of combination therapy with immune modulators on anti-TNF trough levels and antibodies in patients with IBD. *Inflamm Bowel Dis.* 2014 Dec;20(12):2292-8.
109. Biancone L, Onali S, Petruzzello C, et al. Cancer and immunomodulators in inflammatory bowel diseases. *Inflamm Bowel Dis.* 2015 Mar;21(3):674-98.
110. Chaparro M, Ramas M, et al. Extracolonic Cancer in Inflammatory Bowel Disease: Data from the GETECCU Eneida Registry. *Am J Gastroenterol.* 2017 May 23.
111. Yarur AJ, Kubiliun MJ, Czul F, Sussman DA, et al. Concentrations of 6-thioguanine nucleotide correlate with trough levels of infliximab in patients with inflammatory bowel disease on combination therapy. *Clin Gastroenterol Hepatol.* 2015 Jun;13(6):1118-24.e3.
112. Drobne D, Bossuyt P, Breynaert C, et al. Withdrawal of immunomodulators after co-treatment does not reduce trough level of infliximab in patients with Crohn's disease. *Clin Gastroenterol Hepatol.* 2015 Mar;13(3):514-521.e4.



113. Moore C, Corbett G, Moss AC. Systematic Review and Meta-Analysis: Serum Infliximab Levels During Maintenance Therapy and Outcomes in Inflammatory Bowel Disease. *J Crohns Colitis*. 2016;10:619-625.
114. Paul S, Del Tedesco E, Marotte H, Rinaudo-Gaujous M, et al. Therapeutic drug monitoring of infliximab and mucosal healing in inflammatory bowel disease: a prospective study. *Inflamm Bowel Dis*. 2013;19:2568-2576.
115. Papamichael K, Van Stappen T, Vande Casteele N, et al. Infliximab Concentration Thresholds During Induction Therapy Are Associated With Short-term Mucosal Healing in Patients With Ulcerative Colitis. *Clin Gastroenterol Hepatol*. 2016;14:543-549.
116. Ungar B, Levy I, Yavne Y, et al. Optimizing Anti-TNF- $\alpha$  Therapy: Serum Levels of Infliximab and Adalimumab Are Associated With Mucosal Healing in Patients With Inflammatory Bowel Diseases. *Clin Gastroenterol Hepatol*. 2016;14:550-557.e2.
117. Colombel JF, Reinisch W, Mantzaris GJ, et al. Randomised clinical trial: deep remission in biologic and immunomodulator naïve patients with Crohn's disease - a SONIC post hoc analysis. *Aliment Pharmacol Ther*. 2015;41:734-746.
118. Barnes EL, Allegretti JR. Are Anti-Tumor Necrosis Factor Trough Levels Predictive of Mucosal Healing in Patients With Inflammatory Bowel Disease?: A Systematic Review and Meta-Analysis. *J Clin Gastroenterol*. 2016;50:733-741.
119. Baert F, Kondragunta V, Lockton S, et al. Antibodies to adalimumab are associated with future inflammation in Crohn's patients receiving maintenance

- adalimumab therapy: a post hoc analysis of the Karmiris trial. *Gut*. 2016;65:1126-1131.
120. Chiu YL, Rubin DT, Vermeire S, et al. Serum adalimumab concentration and clinical remission in patients with Crohn's disease. *Inflamm Bowel Dis*. 2013;19:1112-1122.
121. Zittan E, Kabakchiev B, Milgrom R et al. Higher Adalimumab Drug Levels are Associated with Mucosal Healing in Patients with Crohn's Disease. *J Crohns Colitis*.
122. Vermeire S, Noman M, Van Assche G, et al. Effectiveness of concomitant immunosuppressive therapy in suppressing the formation of antibodies to infliximab in Crohn's disease. *Gut*. 2007; 56(9):1226–1231.
123. Baert FJ, Lockton S, Hauenstein S, Singh S, Gils A, Vermeire S. Sa1247 antibodies to adalimumab predict inflammation in Crohn's patients on maintenance adalimumab therapy. *Gastroenterology*. 2014; 146(5):S-242.
124. Yarur AJ, Kangala V, Stein DJ, et al. Higher infliximab trough levels are associated with perianal fistula healing in patients with Crohn's disease. *Aliment Pharmacol Ther*. 2017 Apr;45(7):933-940.
125. Brandse JF, Mathôt RA, van der Kleij D, et al. Pharmacokinetic Features and Presence of Antidrug Antibodies Associate With Response to Infliximab Induction Therapy in Patients With Moderate to Severe Ulcerative Colitis. *Clin Gastroenterol Hepatol*. 2016 Feb;14(2):251-258.e2.
126. Yanai H, Lichtenstein L, Assa A, Mazor Y, et al. Clin Levels of drug and antidrug antibodies are associated with outcome of interventions after loss of response to infliximab or adalimumab. *Gastroenterol Hepatol*. 2015 Mar;13(3):522-530.e2.

127. Frederiksen MT, Ainsworth MA, Brynskov J, et al. Antibodies against infliximab are associated with de novo development of antibodies to adalimumab and therapeutic failure in infliximab-to-adalimumab switchers with IBD. *Inflamm Bowel Dis*. 2014 Oct;20(10):1714-21.
128. Van Assche G, Vermeire S, Ballet V, et al. Switch to adalimumab in patients with Crohn's disease controlled by maintenance infliximab: prospective randomised SWITCH trial. *Gut*. 2012 Feb; 61(2):229-34.
129. Williet N, Boschetti G, Fovet M, et al. Association Between Low Trough Levels of Vedolizumab During Induction Therapy for Inflammatory Bowel Diseases and Need for Additional Doses Within 6 Months. *Clin Gastroenterol Hepatol*. 2016 Nov 24. pii: S1542-3565(16)31121-1.
130. Satsangi J, Silverberg MS, Vermeire S, et al. The Montreal classification of inflammatory bowel disease: controversies, consensus, and implications. *Gut*. 2006 Jun; 55(6): 749–753.
131. Harvey RF, Bradshaw JM. A simple index of Crohn's-disease activity. *Lancet*. 1980 Mar 8;1(8167):514.
132. Lewis JD, Chuai S, Nessel L et al. Use of the noninvasive components of the Mayo score to assess clinical response in ulcerative colitis. *Inflamm Bowel Dis*. 2008 Dec;14(12):1660-6.
133. Daperno M, D'Haens G, Van Assche G, et al. Development and validation of a new, simplified endoscopic activity score for Crohn's disease: The SES-CD. *Gastrointest Endosc*. 2004;60:505–12.

134. Sipponen T, Nuutinen H, Turunen U et al. Endoscopic evaluation of Crohn's disease activity: Comparison of the CDEIS and the SES-CD. *Inflamm Bowel Dis.* 2010;16:2131–6.
135. Schroeder KW, Tremaine WJ, Ilstrup DM. Coated oral 5-aminosalicylic acid therapy for mildly to moderately active ulcerative colitis. A randomized study. *N Engl J Med.* 1987 Dec 24;317(26):1625-9.
136. Solem CA, Loftus EV Jr, Tremaine WJ, et al. Correlation of C-reactive protein with clinical, endoscopic, histologic, and radiographic activity in inflammatory bowel disease. *Inflamm Bowel Dis.* 2005 Aug;11(8):707-12
137. Ruutgers P, Feagan BG, Lichtenstein GR, et al. Comparison of scheduled and episodic treatment strategies of Infliximab in Crohn's disease. *Gastroenterology.* 2004;126:402-13.
138. Sandborn WJ, Colombel JF, D'Haens G, et al. One-year maintenance outcomes among patients with moderately-to-severely active ulcerative colitis who responded to induction therapy with adalimumab: subgroup analyses from ULTRA 2. *Aliment Pharmacol Ther.* 2013 Jan;37(2):204-13.
139. Ben-Horin S, Kopylov U, Chowers Y. (2014) Optimizing anti-TNF treatments in inflammatory bowel disease. *Autoimmun Rev.* 2014 Jan;13(1):24-30.
140. Gisbert JP, Panés J. Loss of response and requirement of infliximab dose intensification in Crohn's disease: a review. *Am J Gastroenterol.* 2009;104:760–767
141. Oussalah A, Evesque L, Laharie D, et al. A multicenter experience with infliximab for ulcerative colitis: outcomes and predictors of response,

optimization, colectomy, and hospitalization. *Am J Gastroenterol.*

2010;105:2617–2625

142. Rostholder E, Ahmed A, Cheifetz AS, Moss AC. Outcomes after escalation of infliximab therapy in ambulatory patients with moderately active ulcerative colitis. *Aliment Pharmacol Ther.* 2012;35:562–567.
143. Yanai H, Hanauer SB. Assessing response and loss of response to biological therapies in IBD. *Am J Gastroenterol.* 2011 Apr;106(4):685-98.
144. Reinisch W, Wang Y, Oddens BJ, et al. C-reactive protein, an indicator for maintained response or remission to infliximab in patients with Crohn's disease: a post-hoc analysis from ACCENT I. *Aliment Pharmacol Ther.* 2012 Mar;35(5):568-76.
145. Thorlund K, Druyts E, Mills EJ, et al Adalimumab versus infliximab for the treatment of moderate to severe ulcerative colitis in adult patients naïve to anti-TNF therapy: an indirect treatment comparison meta-analysis. *J Crohns Colitis.* 2014 Jul;8(7):571-81.
146. Vermeire S, Louis E, Carbonez A, et al, Belgian Group of Infliximab Expanded Access Program in Crohn's Disease. Demographic and clinical parameters influencing the short-term outcome of anti-tumor necrosis factor (infliximab) treatment in Crohn's disease. *Am J Gastroenterol.* 2002 Sep; 97(9):2357-63
147. Severs M, Mangen MJ, van der Valk ME et al. COIN study group and the Dutch Initiative on Crohn and Colitis. Smoking is Associated with Higher Disease-related Costs and Lower Health-related Quality of Life in Inflammatory Bowel Disease. *J Crohns Colitis.* 2016 Sep 19. pii: jjw160. [Epub ahead of print]

148. Lunney PC, Kariyawasam VC, Wang RR, et al. Smoking prevalence and its influence on disease course and surgery in Crohn's disease and ulcerative colitis. *Aliment Pharmacol Ther.* 2015 Jul;42(1): 61-70
149. Henriksen M, Jahnsen J, Lygren I, et al IBSSEN Study Group. C-reactive protein: a predictive factor and marker of inflammation in inflammatory bowel disease. Results from a prospective population-based study. *Gut.* 2008 Nov;57(11):1518-23.
150. Kiss LS, Szamosi T, Molnar T, et al; Hungarian IBD Study Group Early clinical remission and normalisation of CRP are the strongest predictors of efficacy, mucosal healing and dose escalation during the first year of adalimumab therapy in Crohn's disease. *Aliment Pharmacol Ther.* 2011 Oct;34(8):911-22.
151. Arias MT, Vande Casteele N, Vermeire S, et al. A panel to predict long-term outcome of infliximab therapy for patients with ulcerative colitis. *Clin Gastroenterol Hepatol.* 2015 Mar;13(3):531-8.
152. Ikhtaire S, Shajib MS, Reinisch W, et al. Fecal calprotectin: its scope and utility in the management of inflammatory bowel disease. *J Gastroenterol.* 2016 May;51(5):434-46.
153. Iborra M, Perez-Gisbert J, Bosca-Watts MM, et al; Spanish Working Group on Crohn's Disease and Ulcerative colitis (GETECCU). Effectiveness of adalimumab for the treatment of ulcerative colitis in clinical practice: comparison between anti-tumour necrosis factor-naïve and non-naïve patients. *J Gastroenterol.* 2016 Oct 8. [Epub ahead of print]

154. Billioud V, Sandborn WJ, Peyrin-Biroulet L. Loss of response and need for adalimumab dose intensification in Crohn's disease: a systematic review. *Am J Gastroenterol*. 2011 Apr;106(4):674-84.
155. Feagan BG, Panaccione R, Sandborn WJ et al. Effects of adalimumab therapy on incidence of hospitalization and surgery in Crohn's disease: results from the CHARM study. *Gastroenterology*. 2008;135(5):1493-9.
156. Vande Casteele N, Khanna R, Levesque BG, et al. The relationship between infliximab concentrations, antibodies to infliximab and disease activity in Crohn's disease. *Gut*. 2015 Oct;64(10):1539-45.
157. Liefferinckx C, Minsart C, Toubreau JF, et al. Infliximab Trough Levels at Induction to Predict Treatment Failure During Maintenance. *Inflamm Bowel Dis*. 2017 May 11.
158. Brandse JF, Mould D, Smeekes O, et al. A Real-life Population Pharmacokinetic Study Reveals Factors Associated with Clearance and Immunogenicity of Infliximab in Inflammatory Bowel Disease. *Inflamm Bowel Dis*. 2017 Apr;23(4):650-660.
159. Nanda KS, Cheifetz AS, Moss AC. Impact of antibodies to infliximab on clinical outcomes and serum infliximab levels in patients with inflammatory bowel disease (IBD): a meta-analysis. *J Gastroenterol*. 2013 Jan;108(1):40-7;.
160. Boschetti G, Garnerio P, Moussata D, et al. Accuracies of serum and fecal S100 proteins (calprotectin and calgranulin C) to predict the response to TNF antagonists in patients with Crohn's disease. *Inflamm Bowel Dis*. 2015 Feb;21(2):331-6.
161. National Institute for Health and Clinical Excellence (2016) Therapeutic monitoring of TNF-alpha inhibitors in Crohn's disease (LISA-TRACKER

ELISA kits, IDKmonitor ELISA kits, and Promonitor ELISA kits). NICE guideline (DG22)

162. Gonczi L, Vegh Z, Golovics PA, et al. Prediction of Short- and Medium-term Efficacy of Biosimilar Infliximab Therapy. Do Trough Levels and Antidrug Antibody Levels or Clinical And Biochemical Markers Play the More Important Role? *J Crohns Colitis*. 2017 Jun 1;11(6):697-705.
163. Sprakes MB, Ford AC, Warren L, Greer D, Hamlin J. Efficacy, tolerability, and predictors of response to infliximab therapy for Crohn's disease: a large single centre experience. *J Crohns Colitis* 2012; 6: 143–53.
164. D'Haens GR, Panaccione R, Higgins PDR, et al. The London Position Statement of the World Congress of Gastroenterology on Biological Therapy for IBD with the European Crohn's and Colitis Organization: when to start, when to stop, which drug to choose, and how to predict response? *Am J Gastroenterol* 2011; 106: 199–212; quiz 213.
165. Echarri A, Ferreiro R, Fraga-Iriso R, et al. Sa1264 drug trough levels and primary nonresponse to antiTNF therapy in moderate-severe crohn disease. Results of the optimiza study. *Gastroenterology* 2014; 146: S–247.
166. Ungar B, Mazor Y, Weisshof R, et al. Induction infliximab levels among patients with acute severe ulcerative colitis compared with patients with moderately severe ulcerative colitis. *Aliment Pharmacol Ther*. 2016 Jun;43(12):1293-9.
167. Ungar B, Kopylov U, Engel T, et al. Addition of an immunomodulator can reverse antibody formation and loss of response in patients treated with adalimumab. *Aliment Pharmacol Ther*. 2017 Jan;45(2):276-282.



168. Singh S, Andersen NN, Andersson M, et al. Comparison of Infliximab and Adalimumab in Biologic-Naive Patients With Ulcerative Colitis: A Nationwide Danish Cohort Study. *Clin Gastroenterol Hepatol*. 2017 Aug;15(8):1218-1225.e7.
169. Papamichael K, Baert F, Tops S, et al Post-Induction Adalimumab Concentration is Associated with Short-Term Mucosal Healing in Patients with Ulcerative Colitis. *J Crohns Colitis*. 2017 Jan;11(1):53-59.
170. Peyrin-Biroulet L, Billioud V, D'Haens G, et al. Development of the Paris definition of early Crohn's disease for disease-modification trials: results of an international expert opinion process. *Am J Gastroenterol*. 2012;107:1770–1776.
171. Colombel JF, Sandborn WJ, Rutgeerts P, et al. Adalimumab for maintenance of clinical response and remission in patients with Crohn's disease: the CHARM trial. *Gastroenterology* 2007; 132: 52–65.
172. Thia KT, Sandborn WJ, Lewis JD, et al. Defining the optimal response criteria for the Crohn's disease activity index for induction studies in patients with mildly to moderately active Crohn's disease. *Am J Gastroenterol*. 2008 Dec;103(12):3123-31.
173. Rutgeerts P, D'Haens G, Targan S, et al. Efficacy and safety of retreatment with anti-tumor necrosis factor antibody (infliximab) to maintain remission in Crohn's disease. *Gastroenterology* 1999; 117: 761–9.
174. Hyams J, Crandall W, Kugathasan S, et al. Induction and maintenance infliximab therapy for the treatment of moderate-to-severe Crohn's disease in children. *Gastroenterology* 2007; 132: 863–73.

175. Ma C, Huang V, Fedorak DK, et al. Crohn's disease outpatients treated with adalimumab have an earlier secondary loss of response and requirement for dose escalation compared to infliximab: a real life cohort study. *J Crohns Colitis*. 2014 Nov;8(11):1454-63.
176. Ma C, Huang V, Fedorak D et al. Outpatient Ulcerative Colitis Primary Anti-TNF Responders Receiving Adalimumab or Infliximab Maintenance Therapy Have Similar Rates of Secondary Loss of Response. *J Clin Gastroenterol*. 2015 Sep;49(8):675-82.
177. Cohen RD, Lewis JR, Turner H, et al. Predictors of adalimumab dose escalation in patients with Crohn's disease at a tertiary referral center. *Inflamm Bowel Dis* 2012; 18: 10–6.
178. Sandborn WJ, Colombel JF, Schreiber S, et al. Dosage adjustment during long-term adalimumab treatment for Crohn's disease: clinical efficacy and pharmacoeconomics. *Inflamm Bowel Dis* 2011; 17: 141–51.
179. Afif W, Loftus EV, Faubion WA, et al. Clinical utility of measuring infliximab and human anti-chimeric antibody concentrations in patients with inflammatory bowel disease. *Am J Gastroenterol* 2010; 105: 1133–9.
180. Papamichael K, Chachu KA, Vajravelu R, et al. Improved Long-term Outcomes of Patients With Inflammatory Bowel Disease Receiving Proactive Compared With Reactive Monitoring of Serum Concentrations of Infliximab. *Clin Gastroenterol Hepatol*. 2017 Mar 29. pii: S1542-3565(17)30385-3.
181. Qiu Y, Chen BL, Mao R, Zhang SH, et al. Systematic review with meta-analysis: loss of response and requirement of anti-TNF dose intensification in Crohn's disease. *J Gastroenterol*. 2017 May;52(5):535-554.

182. Dumitrescu G, Amiot A, Seksik P, et al. The outcome of infliximab dose doubling in 157 patients with ulcerative colitis after loss of response to infliximab. *Aliment Pharmacol Ther.* 2015 Nov;42(10):1192-9.
183. Sandborn WJ, Rutgeerts P, Enns R, et al. Adalimumab induction therapy for Crohn disease previously treated with infliximab: a randomized trial. *Ann Intern Med.* 2007 Jun 19;146(12):829-38. Epub 2007 Apr 30.
184. Gisbert JP, Marín AC, McNicholl AG, et al. Systematic review with meta-analysis: the efficacy of a second anti-TNF in patients with inflammatory bowel disease whose previous anti-TNF treatment has failed. *Aliment Pharmacol Ther.* 2015 Apr;41(7):613-23.
185. Peake ST, Bernardo D, Mann ER, et al. Mechanisms of action of anti-tumor necrosis factor  $\alpha$  agents in Crohn's disease. *Inflamm Bowel Dis.* 2013 Jun;19(7):1546-55.
186. Ben-Horin S, Chowers Y. Tailoring anti-TNF therapy in IBD: drug levels and disease activity. *Nature Reviews Gastroenterology & Hepatology.* 2014 Apr;11(4):243-55.
187. Mao EJ, Hazlewood GS, Kaplan GG, et al. Systematic review with meta-analysis: comparative efficacy of immunosuppressants and biologics for reducing hospitalisation and surgery in Crohn's disease and ulcerative colitis. *Aliment Pharmacol Ther.* 2017 Jan;45(1):3-13.
188. Targownik LE, Tenakaroon A, Leung S, et al. Temporal Trends in Initiation of Therapy With Tumor Necrosis Factor Antagonists for Patients With Inflammatory Bowel Disease: A Population-based Analysis. *Clin Gastroenterol Hepatol.* 2017 Feb 24. pii: S1542-3565(17)30195-7.

189. Papamichael K, Cheifetz AS. Therapeutic Drug Monitoring in IBD: The New Standard-of-Care for Anti-TNF Therapy. *Am J Gastroenterol*. 2017 May;112(5):673-676.
190. Ananthakrishnan AN, Sakuraba A, Barnes EL, et al. The benefit of combination therapy depends on disease phenotype and duration in Crohn's disease. *Aliment Pharmacol Ther*. 2017 May 3.
191. Vermeire S, Van Assche G, Rutgeerts P. C-reactive protein as a marker for inflammatory bowel disease. *Inflamm Bowel Dis*. 2004 Sep;10(5):661-5.
192. Nunes T, Etchevers MJ, García-Sánchez V, et al. Impact of Smoking Cessation on the Clinical Course of Crohn's Disease Under Current Therapeutic Algorithms: A Multicenter Prospective Study. *Am J Gastroenterol*. 2016 Mar;111(3):411-9.
193. Parsi MA, Achkar JP, Richardson S, et al. Predictors of response to infliximab in patients with Crohn's disease. *Gastroenterology*. 2002 Sep;123(3):707-13.
194. Roblin X, Duru G, Williet N, et al. Development and Internal Validation of a Model Using Fecal Calprotectin in Combination with Infliximab Trough Levels to Predict Clinical Relapse in Crohn's Disease. *Inflamm Bowel Dis*. 2017 Jan;23(1):126-132.
195. Bar-Yoseph H, Waterman M, Almog R, et al. Prevention of Antidrug Antibody Formation to Infliximab in Crohn's Patients With Prior Failure of Thiopurines. *Clin Gastroenterol Hepatol*. 2017 Jan;15(1):69-75.
196. Qiu Y, Mao R, Chen BL et al. Effects of Combination Therapy with Immunomodulators on Trough Levels and Antibodies Against Tumor Necrosis

- Factor Antagonists in Patients With Inflammatory Bowel Disease: A Meta-Analysis. *Clin Gastroenterol Hepatol*. 2017 Feb 14. pii: S1542-3565(17)30152-0.
197. Van Stappen T, Vande Casteele N, Van Assche G, et al. Clinical relevance of detecting anti-infliximab antibodies with a drug-tolerant assay: post hoc analysis of the TAXIT trial. *Gut*. 2017 Apr 27. pii: gutjnl-2016-313071.
198. Hazlewood GS, Rezaie A, Borman M, et al. Comparative effectiveness of immunosuppressants and biologics for inducing and maintaining remission in Crohn's disease: a network meta-analysis. *Gastroenterology*. 2015 Feb;148(2):344-54.e5;
199. Ananthkrishnan AN, Cagan A, Cai T, et al. Comparative effectiveness of infliximab and adalimumab in Crohn's disease and ulcerative colitis. *Inflamm Bowel Dis*. 2016 Apr; 22(4): 880–885
200. Singh S, Heien HC, Lindsey R et al. Comparative Effectiveness and Safety of Infliximab and Adalimumab in Patients with Ulcerative Colitis. *Aliment Pharmacol Ther*. 2016 May; 43(9): 994–1003.
201. Strik AS, van den Brink GR, et al. Suppression of anti-drug antibodies to infliximab or adalimumab with the addition of an immunomodulator in patients with inflammatory bowel disease. *Aliment Pharmacol Ther*. 2017 Apr;45(8):1128-1134.